

PS12 Series High Performance Solid State Relays For AC Loads up to 10A @ 250Vrms

Product Facts

- Approved to DSCC drawing 86031
- Optically coupled all solid state relay
- TTL compatible input
- Zero voltage turn-on for low EMI
- Custom power package with screw terminals

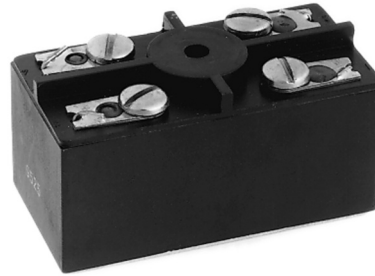

The PS12 series solid state relay is designed for AC power switching up to 10 amps at 250Vrms. The circuit employs back-to-back SCRs with zero voltage turn-on for reliable switching of

resistive or reactive loads. TTL compatible input circuitry is optically isolated to 1,500Vrms from the AC load circuit. The relay is offered in two versions: the PS12-1Y with "Y" level screening per

MIL-PRF-28750D, and the PS12-1W screened per Tyco Electronics specifications for Kilovac relays, equivalent to former "W" level of Mil-R-28750.

10
Kilovac Solid State Relays

Kilovac Part Number	DSCC Part Number	Screening Level
PS12-1Y	86031-001	Y
PS12-1W	N/A	W

Circuit Diagram

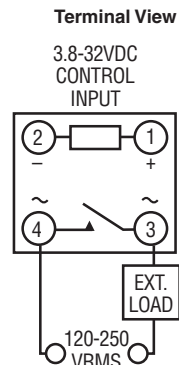

Outline Drawing

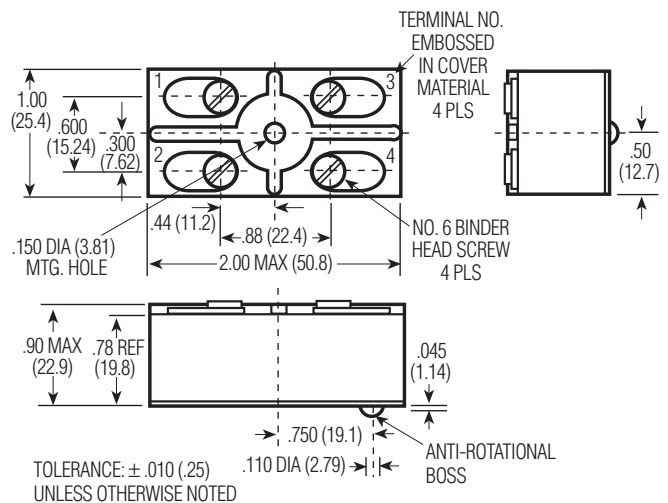

PS12 Series High Performance Solid State Relays For AC Loads up to 10A @ 250Vrms (Continued)

Environmental Characteristics

Ambient Temperature Range —

Operating — -55°C to +95°C
Storage — -55°C to +110°C

Vibration Resistance —

30 G's, 78-2,000 Hz

Shock Resistance —

100 G's, 6 ms pulse

Constant Acceleration Resistance —

100 G's

Mechanical Characteristics

Weight (max.) —

3 oz. (85 grams)

Materials —

Case — Plastic, self-extinguishing, epoxy filled

Terminals — Brass, nickel-plated

Base Plate — Aluminum

NOTE: Do not exceed 125 in-oz when tightening screws.

Electrical Specifications (-55°C to +95°C unless otherwise specified)

Input

Input supply voltage range (Vcc)	3.8 - 32 Vdc
Input current (max.) @ 5Vdc	16mAdc
Must turn-on voltage	3.8Vdc
Must turn-off voltage	1Vdc
Reverse voltage protection	-32Vdc

I/O

Dielectric strength (min.)	1,500V rms/60 Hz.
Insulation resistance (min.) @ 500Vdc	10 ⁹ ohms
Capacitance (max.)	15pF

Output

Output current rating (max.)	10A rms (Fig. 2, Note 1)
Surge current (max.)	100A pk (Fig. 1, Note 2)
Continuous load voltage (max.)	250V rms
Transient blocking voltage (max.)	460V pk
Frequency range	45 - 440 Hz.
Output voltage drop (max.) @ 25A load current	1.5V rms
Off-state leakage current (max.) @ 220V rms/400 Hz.	9mA rms
Turn-on time (max.)	1/2 cycle
Turn-off time (max.)	1 cycle
Off-state dv/dt (min.), with snubber	200V / μ s (Note 3)
Zero voltage turn-on window (max.)	\pm 15V pk
Output chip junction temperature (max.)	125°C (Note 1)
Thermal resistance (max.), junction to ambient	11.5°C/W
Thermal resistance (max.), junction to case	2.0°C/W
Fusing I ² T, 1 ms (max.)	150A ² s
Load power factor (min.)	0.2
Power dissipation (max.)	1.5W/A

Notes

1. Operation at elevated load currents up to 10 amps is dependent on the use of suitable heatsink to limit junction temperature.
2. Heating of output chips during and after a surge may cause loss of output blocking capability until junction temperature falls below maximum rating.
3. Internal snubber network is provided across output chips.

Figure 1 - Peak Surge Current vs. Surge Current Duration

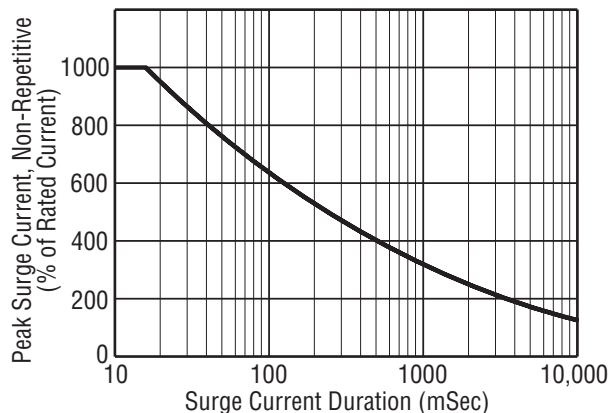
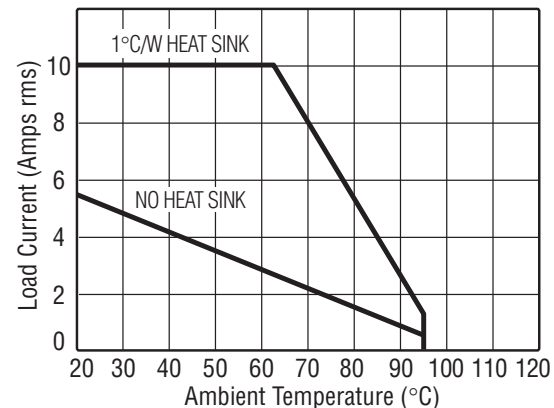

Figure 2 - Load Current vs. Temperature



Mouser Electronics

Authorized Distributor

Click to View Pricing, Inventory, Delivery & Lifecycle Information:

[TE Connectivity:](#)

[PS12-1Y](#)