

## Series 90 Modutrol IV™ Motors

### PRODUCT DATA

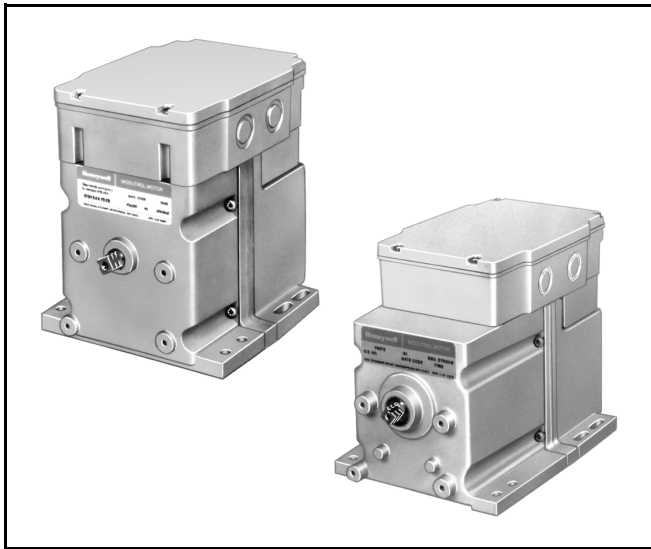

### APPLICATION

The Series 90 Modutrol IV™ Motors are spring return and non-spring return modulating proportional control motors. Use these motors with controllers that provide a Series 90 output to operate dampers or valves.

### FEATURES

- Directly replaces M934A,D, M941, M944A,C,D, M945A,D,F, M954, M965, and M975 motors.
- Oil-immersed motor and gear train for reliable performance and long life.
- Integral junction box provides NEMA 3 weather protection.
- Motor and circuitry operate from 24 Vac. Models available with factory installed transformer, or a field-added internal transformer.
- Quick-connect terminals standard—screw terminal adapter available.
- Adapter bracket for matching shaft height of older motors standard with TRADELINE motors.
- Field adjustable stroke (90° to 160°) models available.
- Nominal timing of 30 seconds for 90° stroke and 60 seconds for 160° stroke standard. Other timings available.
- Die-cast aluminum housing.
- Integral auxiliary switches available factory mounted, or can be field added to TRADELINE® models.
- Integral spring returns motor shaft to normal position (fully open or fully closed, depending on model) upon power interruption.
- Field addable interface modules can be mounted in the junction box to upgrade the motor to Series 70 (electronic) control.
- TRADELINE spring return motors can operate valve linkages from power end or auxiliary end shafts for normally closed or normally open valve applications.

### Contents

Application .....	1
Features .....	1
Specifications .....	2
Ordering Information .....	2
Installation .....	5
Settings and Adjustments .....	8
Operation .....	10
Replacement .....	12

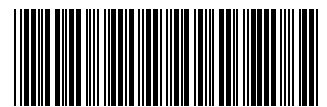

# SPECIFICATIONS

**TRADELIN Models:** Selected and packaged to provide ease of stocking, ease of handling and maximum replacement value. Specifications are the same as those of standard models unless specified otherwise. TRADELINE models have auxiliary switch cams.

**NOTE:** Auxiliary switches can only be added to motors that include auxiliary switch cams. (These cams cannot be field-added.)

**Modutrol IV Order Number Guide:** See Table 1.

**Table 1. Modutrol IV Order Number Guide**

<b>M</b>	Motor					
	<b>91</b>	Proportioning Series 90 Control				
	<b>94</b>	Flame Safeguard Firing Rate Motor				
	<b>6</b>	—	35 lb-in. Non-Spring Return			
	<b>7</b>	25 lb-in. Spring Return	75 lb-in. Non-Spring Return			
	<b>8</b>	60 lb-in. Spring Return	150 lb-in. Non-Spring Return			
	<b>9</b>	—	300 lb-in. Non-Spring Return			
	<b>1</b>	Single-ended shaft	Non-Spring Return			
	<b>2</b>		Normally Closed (NC) Spring Return <sup>a</sup>			
	<b>3</b>		Normally Open (NO) Spring Return <sup>b</sup>			
	<b>4</b>	Dual-ended shaft	Non-Spring Return			
	<b>5</b>		Normally Closed (NC) Spring Return <sup>a</sup>			
	<b>6</b>		Normally Open (NO) Spring Return <sup>b</sup>			
		<b>A</b>	0 Auxiliary Switches	Fixed Stroke	Normally Closed	
		<b>B</b>	1 Auxiliary Switch			
		<b>C</b>	2 Auxiliary Switches			
		<b>D</b>	0 Auxiliary Switches	Adjustable Stroke	Normally Open	
		<b>E</b>	1 Auxiliary Switch			
		<b>F</b>	2 Auxiliary Switches			
		<b>G</b>	0 Auxiliary Switches	Fixed Stroke	Normally Closed	
		<b>v<sup>c</sup></b>	0 Auxiliary Switches	Fixed Stroke		
<b>M</b>	<b>91</b>	<b>8</b>	<b>4</b>	<b>A</b>	<b>XXXX</b>	See Catalog for Complete O.S. Number

<sup>a</sup> Electrically normally closed. Shaft rotates clockwise (as viewed from the power end) with control signal increase. Motor drives to normally closed position when powered with control wiring not connected.

<sup>b</sup> Electrically normally open. Shaft rotates counterclockwise (as viewed from the power end) with control signal increase. Motor drives to normally open position when powered with control wiring not connected.

<sup>c</sup> Models available special order only. Contact your Honeywell Sales Representative.

**NOTE:** Torque designation corresponds to torque rating at standard timing (nominally 60 sec for 160° and 30 sec for 90° except for 300 lb-in. motors which have timings of 2 or 4 min).

# ORDERING INFORMATION

When purchasing replacement and modernization products from your TRADELINE® wholesaler or distributor, refer to the TRADELINE® Catalog or price sheets for complete ordering number.

If you have additional questions, need further information, or would like to comment on our products or services, please write or phone:

1. Your local Home and Building Control Sales Office (check white pages of your phone directory).
2. Home and Building Control Customer Relations  
Honeywell, 1885 Douglas Drive North  
Minneapolis, Minnesota 55422-4386

In Canada—Honeywell Limited/Honeywell Limitée, 35 Dynamic Drive, Scarborough, Ontario M1V 4Z9.  
International Sales and Service Offices in all principal cities of the world. Manufacturing in Australia, Canada, Finland, France, Germany, Japan, Mexico, Netherlands, Spain, Taiwan, United Kingdom, U.S.A.

**Dimensions:** See Fig. 1.

**Electrical Ratings:** See Table 3.

**Control Inputs:** Proportional, Series 90.

NOTE: Motor Series 90 control can be either Electronic, or Mechanical (135 ohm).

**Auxiliary Switch Ratings:** See Table 4.

**Ambient Temperature Ratings:**

Maximum: 150°F (66°C) at 25% duty cycle.  
Minimum: -40°F (-40°C).

NOTE: 25% duty cycle indicates that the motor operates for 6 out of every 24 hours.

**Dead Weight Load On Shaft:**

Power or Auxiliary End: 200 lb (90.8 kg) maximum.  
Maximum Combined Load: 300 lb (136 kg). (Dual shaft motors only.)

**Crankshaft:** 3/8 in. (9.5 mm) square. (Some models have double-ended shafts.)

**Stroke:**

Fixed Stroke Models: Available 90° or 160°.  
Adjustable Stroke Models: Available field adjustable from 90° to 160° (See Stroke Setting Procedure).

**Timing And Torque:** See Table 5.

**Approvals:**

Underwriters Laboratories Inc. Listed: File No. E4436, Guide No. XAPX.  
Canadian Standards Association Certified: General Listed File No. LR1620, Guide 400-E.

NOTE: CE compliance can be attained with the proper accessories (such as the 4074EZE).

**Accessories:**

198162JA Internal Transformer; 24 Vac 50/60 Hz primary, 24 Vac secondary (for electrical isolation).  
198162EA Internal Transformer; 120 Vac 50/60 Hz primary, 24 Vac secondary.  
198162GA Internal Transformer; 220 Vac 50/60 Hz primary, 24 Vac secondary.  
198162AA Internal Transformer; 120/208/240 Vac 50/60 Hz primary, 24 Vac secondary.  
220736 Internal Auxiliary Switch Kit can be field-installed on TRADELINE models. One- (220736A) and Two- (220736B) switch kits available.  
220741A Screw Terminal Adapter converts the standard quick-connect terminals to screw terminals.  
221455A Infinitely Adjustable Crank Arm approximately 0.75 inch shorter than the 4074ELY Crank Arm, can rotate through downward position and clear base of motor without requiring use of adapter bracket.

221508A Resistor Board plugs onto Series 90 Motor quick-connect wire terminals. Provides same functionality as 4074BYK, 4074EAU, 4074EDC, or 4074EED Resistor Kits.  
4074BYK Series 90 Resistor Kit provides for unison control of up to six Series 90 Motors.  
4074EAU W973 Resistor Kit provides for control of two or three Series 90 Motors from a W973 Single-zone Logic Panel or W7100 Discharge Air Controller.  
4074EDC 4-20 mA Resistor Kit drives one Series 90 Motor from a 4-20 mA controller.  
4074EED Unison Control 4-20 mA Resistor Kit provides for control of up to four Series 90 Motors from one 4-20 mA controller.  
4074ERU Weatherproofing Kit provides NEMA 3 rating for Modutrol IV Motors mounted in position other than upright.  
4074EZE Bag Assembly with parts to provide CE compliance.  
7617ADW Crank Arm approximately 0.75 inch shorter than 7616BR Crank Arm. Can rotate through downward position and clear base of motor without requiring use of adapter bracket.  
ES650-117 Explosion-Proof Housing encloses motor for use in explosive atmospheres. Not for use with Q5001 (or any other valve linkages). Order separately from O-Z/Gedney Inc. To order, contact: O-Z/Gedney, Nelson Enclosures and Controls, (918) 641-7381 or (918) 641-7374; or write to: O-Z/Gedney, Nelson Enclosures and Controls P.O. Box 471650 Tulsa, OK 74147-1650  
Requires Honeywell 7617DM Coupling.  
Q100 Linkage connects Modutrol® motor to V51 Butterfly Valve. Requires the 220738A adapter bracket (packed with TRADELINE Modutrol IV motors).  
Q181 Auxiliary Potentiometer for sequence or unison control of 1 to 4 additional modulating (Series 90) motors.  
Q209E,F Potentiometer limits motor minimum position.  
Q5001 Bracket and Linkage Assembly connects Modutrol motor to a water or steam globe valve.  
Q605 Damper Linkage connects motor to damper. Includes motor crank arm.  
Q607 External Auxiliary Switch controls auxiliary equipment as a function of motor position.  
Q7130A Interface Module with selectable voltage ranges (4-7 Vdc, 6-9 Vdc, and 10.5-13.5 Vdc) adapts motor to M71XX function.  
Q7230A Interface Module with selectable control (2-10 Vdc or 4-20 mA) and adjustable zero and span adapts motor to M72XX function.  
Q7330A Interface Module for W936 Economizer applications adapts motor to M73XX function.  
Q7630A Interface Module for 14-17 Vdc control with minimum position capability adapts motor to M76XX function.

**Table 2. Modutrol Motor Cross-Reference.**

Original Motor	Replacements
M944A,C,D, M954	M9181, M9194, M9191, M9194
M965, M975	M9172, M9175
M934D	M9161, M9164, M9171, M9174
M945A,D,F, M955	M9182, M9185, M9183, M9186
M941	M9481, M9484, M9491, M9494

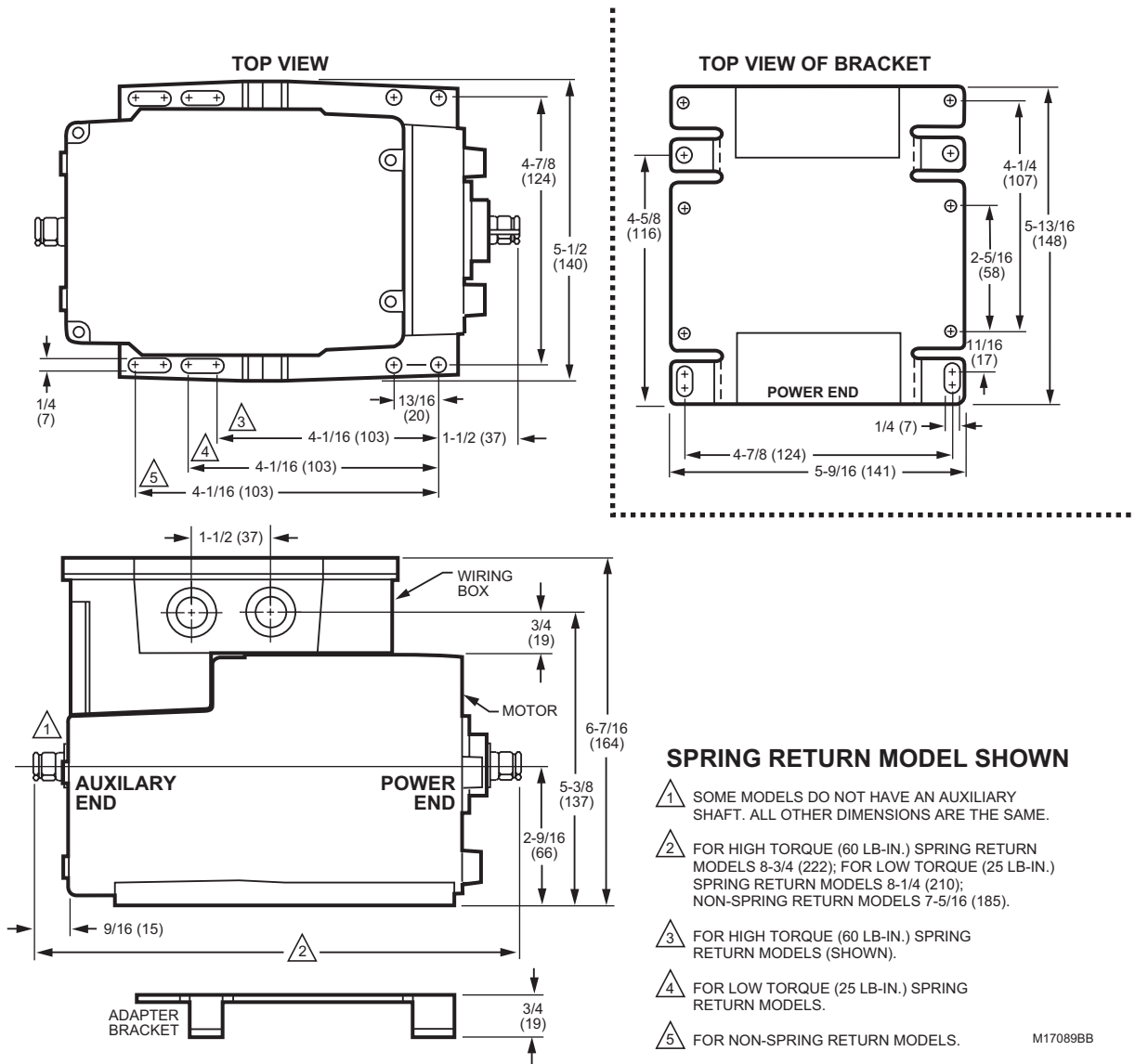

Fig. 1. Modutrol IV Motor mounting dimensions in inches (mm).

Table 3. Series 90 Modutrol Motor Power Consumption Ratings.

Internal Transformer	Power Consumption									
	Non-Spring Return Motors						Spring Return Motors			
	150 and 300 lb-in. Torque		75 lb-in. Torque		35 lb-in. Torque		60 lb-in. Torque		25 lb-in. Torque	
	(VA)	(W)	(VA)	(W)	(VA)	(W)	(VA)	(W)	(VA)	(W)
No	20	18	17	16	15	14	24	23	22	21
Yes	29	23	27	21	24	19	34	28	32	26

Table 4. Auxiliary Switch Ratings (in Amps).

Single Contact Rating <sup>a</sup>	120 V	240 V
Full Load	7.2	3.6
Locked Rotor	43.2	21.6

<sup>a</sup> 40 VA pilot duty, 120/240 Vac on opposite contact.

**Table 5. Series 90 Modutrol Motor Timing and Torque Ratings.**

Nominal Timing <sup>a</sup> in sec		Rated Torque in lb-in. (N•m) <sup>b</sup>			
		Normal Running Torque		Breakaway Torque <sup>c</sup>	
90°	160°	Spring Return	Non-Spring Return	Spring Return	Non-Spring Return
30	60	25 (2.8)	35 (4)	50 (5.7)	70 (8)
15 <sup>d</sup> /30	30 <sup>d</sup> /60	60 (6.8)	75 (8.5)	120 (13.6)	150 (17)
30	60	—	150 (17)	—	300 (34)
60	120	—	300 (34)	—	600 (68)

<sup>a</sup> Timings apply to all TRADELINE models. Some OEM models are available with non-standard timing/torque.

<sup>b</sup> The torque rating for dual-ended shaft motors is the sum of the shaft torques (power-end torque plus auxiliary-end torque).

<sup>c</sup> Breakaway torque is maximum torque available to overcome occasional large loads such as a seized damper or valve.

<sup>d</sup> Low timing is for M9184D1005 only.

NOTE: Some 150 lb-in. and 300 lb-in. torque adjustable stroke motors have timings that are twice that of their fixed stroke counterparts.

**IMPORTANT**

*Never use a Modutrol Motor continuously at the Breakaway Torque rating.*

## INSTALLATION

### When Installing this Product...

1. Read these instructions carefully. Failure to follow them could damage the product or cause a hazardous condition.
2. Check the ratings given in the instructions and on the product to make sure the product is suitable for your application.
3. Installer must be a trained, experienced service technician.
4. After installation is complete, check out product operation as provided in these instructions.



### CAUTION

**Electrical Shock or Equipment Damage Hazard.**  
**Can shock individuals or short equipment circuitry.**

Disconnect all power supplies before installation. Motors with auxiliary switches can have more than one disconnect.



### CAUTION

**Equipment Damage Hazard.**  
**Can damage the motor beyond repair.**

Never turn the motor shaft by hand or with a wrench. Forcibly turning the motor shaft damages the gear train and stroke limit contacts.

**IMPORTANT**

*Always conduct a thorough checkout when installation is complete.*

### Location

Allow enough clearance for installing accessories and motor servicing when selecting a location (see Fig. 1). If located outdoors, use liquid-tight conduit connectors with the junction box to provide NEMA 3 weather protection. If mounted outdoors in a position other than upright, install a 4074ERU Weatherproofing Kit and liquid-tight connectors to provide NEMA 3 protection.



### CAUTION

**Motor Damage Hazard.**

**Deteriorating vapors and acid fumes can damage metal parts.**

Install motor in areas free of acid fumes and other deteriorating vapors.

In excessive salt environments, mounting base and screws should be zinc or cadmium plated, not stainless steel or brass. Use the 220738A Adapter Bracket for mounting on these surfaces.

### Mounting



### CAUTION

**Equipment Damage Hazard.**

**Can damage the motor beyond repair.**

Always install motors with the crankshaft horizontal. Improper motor mounting can result in inadequate motor gear train lubrication.

Use the following guidelines for proper motor mounting:

- Always install motors with the crankshaft horizontal.
- Mounting flanges extending from motor housing base are drilled for 1/4 inch (6.4 mm) machine screws or bolts.
- Non-Spring Return Motors are shipped from the factory in the closed position (at the limit of counterclockwise rotation, as viewed from the power end of the motor).
- Spring Return Motors are shipped from the factory in their normal position:
  - Normally closed models: shipped at limit of counterclockwise rotation, as viewed from the power end of the motor.
  - Normally open models: shipped at limit of clockwise rotation, as viewed from the power end of the motor.

NOTE: Refer to Fig. 2 for graphical representation of full open and full closed.

## Adapter Bracket

The 220738A Adapter Bracket, positioned between the motor and the equipment, raises motor shaft height by 0.75 in. (19 mm) to match that of the former Modutrol® Motor.

The following applications require this bracket:

- Q607 External Auxiliary Switch.
- Damper linkage applications require added clearance to allow:
  - crank arm rotation through the downward position.
  - sufficient damper linkage to reach the motor shaft.
- All valve linkages except the Q5001.

**NOTE:** When no bracket is used in replacement applications, damper linkages require adjustment for the new shaft position.

To mount the motor with the bracket (see Fig. 3):

1. Mount the bracket to the equipment with existing or standard bolts.
2. Using the provided bolts, mount the motor to the bracket threaded holes.

For valve linkage applications (other than the Q5001):

1. Mount the bracket to the linkage.
2. Position the motor on the bracket to align the motor shaft with the linkage.
3. Attach the motor to the bracket with the four bolts provided. See Fig. 4.

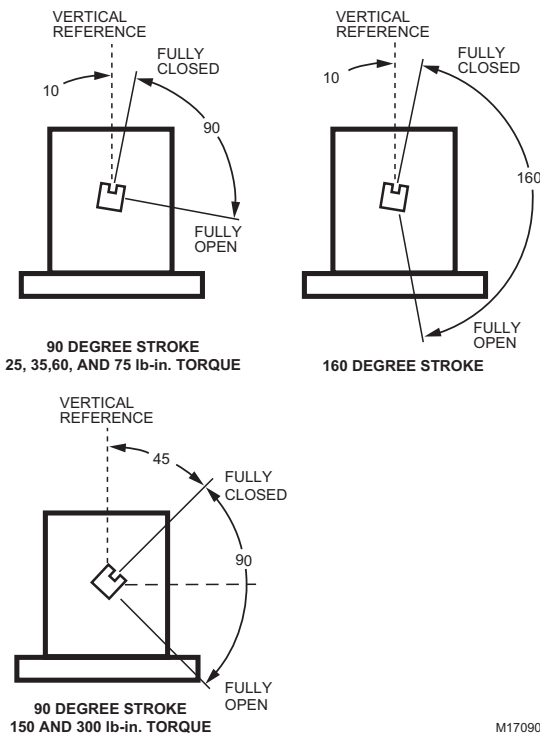

**Fig. 2. Motor shaft positions at stroke limits (viewed from power end of motor).**

## Damper Linkages

The motor does not include a crank arm. Order the crank arm, included in the Q605 Linkage, separately (see Accessories in the Specifications section). For detailed instructions on the assembly of specific linkages, refer to the instruction sheet packed with the linkage.

### ! CAUTION

**Equipment Damage Hazard.**  
**Stalling a motor can damage the drive shaft.**  
 Ensure installation of motors and linkages allows the motor to drive through full stroke without obstruction.

## Valve Linkages

The Q100 Linkage requires the 220738A Adapter Bracket for all valve applications. Applications with the Q5001 Valve Linkage do not require the 220738A Adapter Bracket (see Fig. 4).

## Junction Box

When used with liquid-tight conduit connectors, the junction box provides NEMA 3 weather protection for the motor. The junction box, standard with replacement motors, encloses the terminals and provides knockouts for wiring conduits. Housing an internal transformer or internal auxiliary switches requires use of the junction box.

## Wiring

### ! CAUTION

**Electrical Shock or Equipment Damage Hazard.**  
**Can shock individuals or short equipment circuitry.**  
 Disconnect power supply before installation.

### IMPORTANT

*All wiring must agree with applicable codes, ordinances and regulations.*

1. Ensure that the voltage and frequency stamped on the motor correspond to the power supply characteristics.
2. When connecting several motors in parallel, ensure that the power supply VA rating is large enough to provide power to all motors used without overloading.
3. Fig. 5 shows that the motor terminals are quick-connects located on top of the printed circuit board.
4. To access the wiring compartment:
  - a. Remove the four screws from the junction box top.
  - b. Lift off the cover.
5. Refer to Fig. 6 for typical wiring, and Fig. 8 for internal auxiliary switch connections.

**NOTE:** Reverse motor rotation by switching wires at either the motor or the panel. Reverse rotation on the Series 90 models by reversing the wires at terminals W and B.

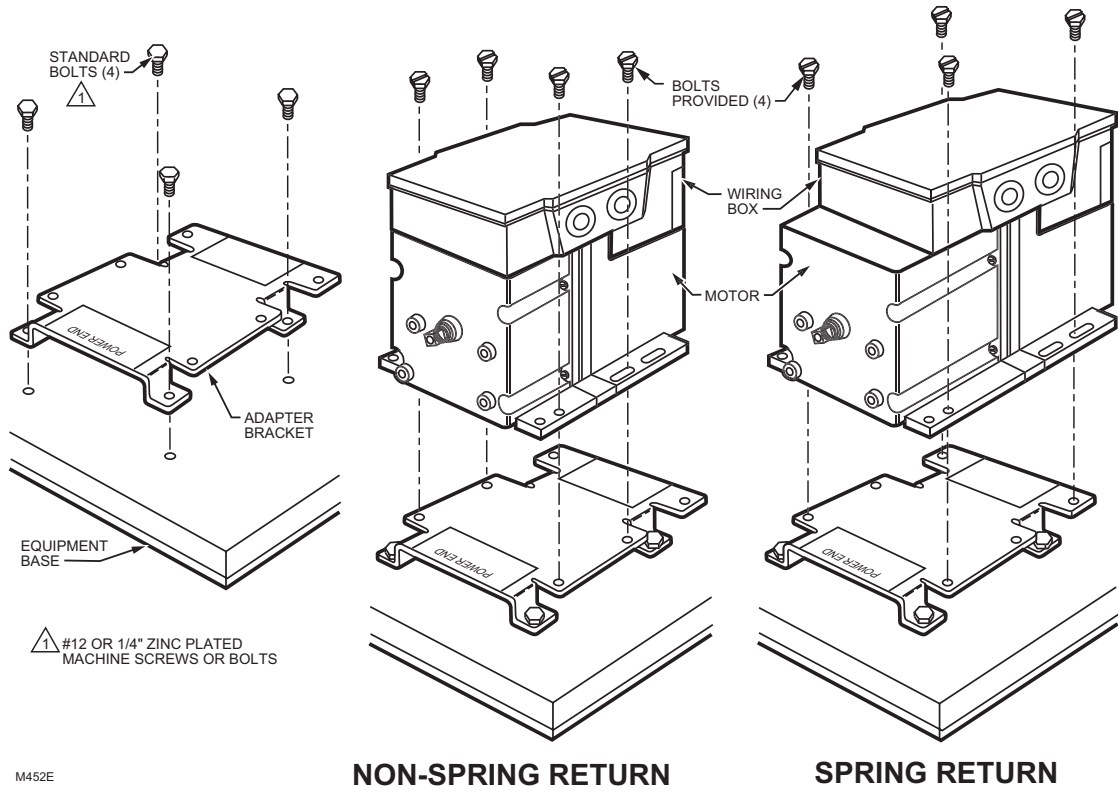

M452E

**Fig. 3. Mounting the motor with an adapter bracket.**

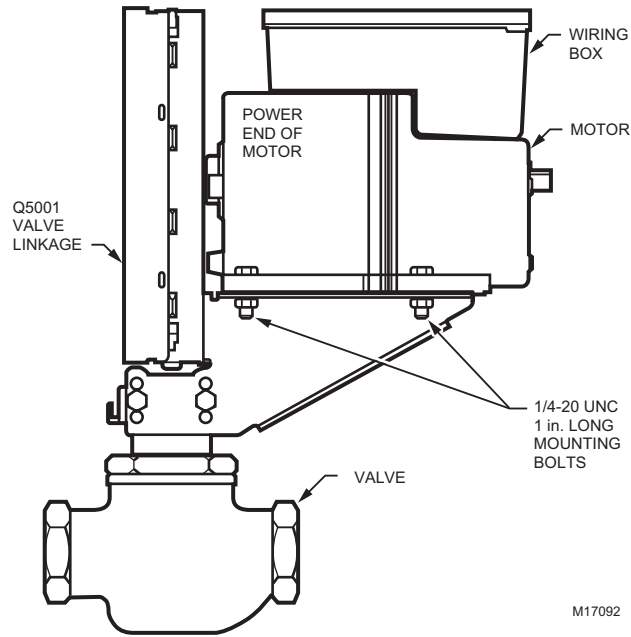

M17092

**Fig. 4. Mounting the motor on a Q5001 Valve Linkage.**

## SETTINGS AND ADJUSTMENTS

### Before Setting Stroke

1. Remove the top cover from the motor.
2. Disconnect the controller from the motor.
3. Connect a potentiometer to the motor as shown in Fig. 7.

#### IMPORTANT

*Detach linkage from motor before adjusting stroke.*

### Setting Stroke

On adjustable stroke motors, stroke is field-adjustable between 90° and 160°:

- The mechanical adjustment (cams) establishes the fully open (clockwise, as viewed from the power end) and fully closed positions of the motor shaft.
- The electrical adjustment (trim pot) matches the feedback resistance change to the motor stroke.
- TRADELINE motors are shipped with stroke set at 160°.

#### CAUTION

##### Careless Installation Hazard.

**Use of excessive force while adjusting cams damages the motor.**

To avoid damaging motor end switches, set cams by moving only the top of the screwdriver.

#### CAUTION

##### Careless Installation Hazard.

**Forcibly turning the motor shaft damages the gear train and stroke limit contacts.**

Never turn motor shaft manually (by hand or with a wrench).

#### CAUTION

##### Equipment Damage Hazard.

**Can damage the motor beyond repair.**

Set cams by moving the top of the screwdriver only. Pressing screwdriver against cam slot sides or use of excessive force can damage motor end switches.

1. Adjust the trim pot:
  - a. For 160° stroke, turn trim pot fully clockwise.
  - b. For 90° stroke, turn trim pot fully counterclockwise.
2. Drive the motor to mid-position by jumpering R-W-B.
3. Adjust the cams:

- a. For 160° stroke:
  - (1) Insert 1/8 in. screwdriver blade into an inner cam slot and move screwdriver top as far as possible counterclockwise (viewed from power end). See Fig. 9. Repeat in successive cam slots until inner cam is against the counterclockwise stop.
  - (2) For low torque motors (75 lb-in. or less), skip to step 4.
  - (3) Insert 1/8 in. screwdriver blade into an outer cam slot and move screwdriver top as far as possible clockwise (viewed from power end). See Fig. 9. Repeat in successive cam slots until outer cam is against the clockwise stop.
- b. For 90° stroke:
  - (1) Insert 1/8 in. screwdriver blade into an outer cam slot and move screwdriver top as far as possible counterclockwise (viewed from power end). See Fig. 9. Repeat in successive cam slots until outer cam is against the counterclockwise stop.
  - (2) For low torque motors (75 lb-in. or less), skip to step 4.
  - (3) Insert 1/8 in. screwdriver blade into an inner cam slot and move screwdriver top as far as possible clockwise (viewed from power end). See Fig. 9. Repeat in successive cam slots until inner cam is against the clockwise stop.
4. Check the motor stroke before connecting the linkage:
  - a. Remove R-W-B jumper.
  - b. Short R-W. The motor should drive fully clockwise (viewed from power end).
  - c. Remove R-W jumper and short R-B. The motor should drive fully counterclockwise (viewed from power end).
5. Reconnect the controller, replace the motor top cover, and attach the linkage to the motor.

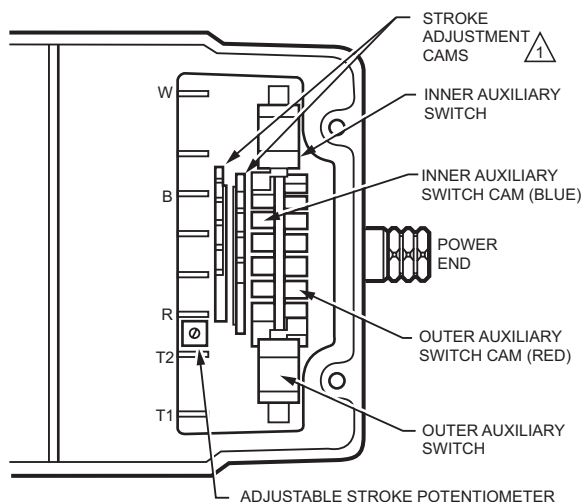

 HIGH TORQUE (150 lb.-in., 300 lb.-in.) MODELS HAVE TWO YELLOW ADJUSTMENT CAMS. LOW TORQUE MODELS HAVE ONLY ONE BROWN INTERNAL STROKE ADJUSTMENT CAM.

NOTE: NOT ALL FEATURES AVAILABLE ON ALL MODELS. M17625A

**Fig. 5. Terminals and adjustments.**



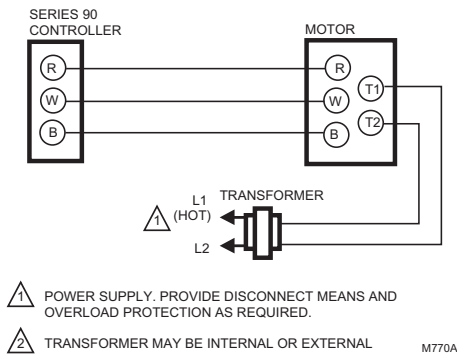

Fig. 6. Typical Series 90 wiring.

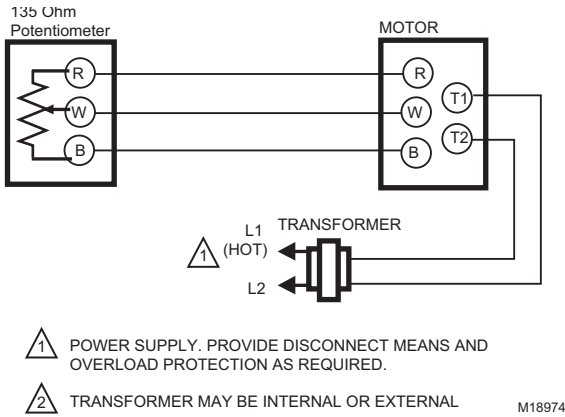

Fig. 7. Wiring for potentiometer control.

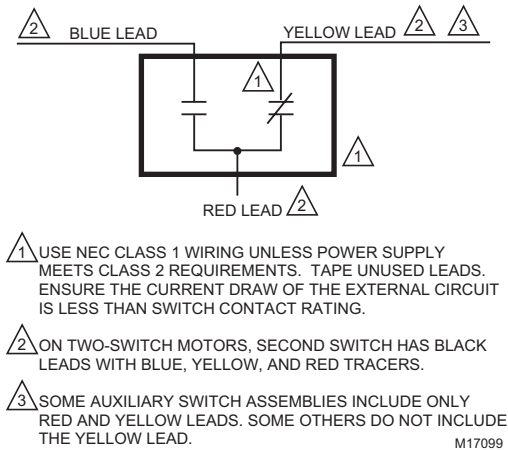

Fig. 8. Auxiliary switch schematic.

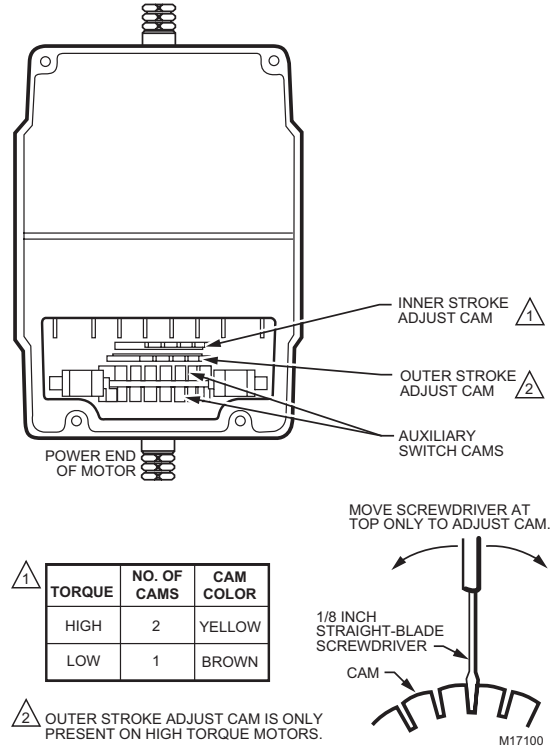

Fig. 9. Stroke adjustment setup for non-spring return models.

### Auxiliary Switches

Adjustable cams actuate the auxiliary switches. These cams can be set to actuate the switches at any angle within the stroke of the motor. Select switch differential of 1° or 10°.

Motors with factory-added auxiliary switches are shipped in the closed position (fully counterclockwise, as viewed from the power end). Auxiliary cam default actuates the switches 30° from full open with a 1° differential. With the motor in the closed (fully counterclockwise) position, the auxiliary switch breaks contacts R-B. See Fig. 8 (or the auxiliary switch Instruction Sheet) for auxiliary switch wiring.

NOTE: Auxiliary switches can only be added to motors that include auxiliary switch cams. (These cams cannot be field-added.)

TRADELINER motors are shipped with auxiliary switch cams that permit acceptance of 220736A,B Internal Auxiliary Switch Kits. Refer to form 63-2228 for 220736A,B installation instructions.

### Auxiliary Switch Adjustment

1. Remove the top cover from the motor to gain access to the motor terminals and auxiliary cams.
2. Disconnect the controller from the motor.
3. Connect a potentiometer to the motor as shown in Fig. 7.
4. Using the potentiometer, drive the motor to the position where the auxiliary equipment is to be switched.
5. For a 1° switch differential, check continuity of the auxiliary switch contacts R-B and rotate the cam as follows:
  - a. If the contacts are open, rotate the cam clockwise until the R-B contacts close.
  - b. If the contacts are closed, rotate the cam counterclockwise until the R-B contacts open.
6. For a 10° switch differential:
  - a. Spring return models: rotate the cam approximately 180° so that the slow-rise portion of the cam actuates the switch. Then check continuity of the auxiliary switch contacts R-B
  - b. Non-spring return models: check continuity of the auxiliary switch contacts R-B.
7. Rotate the cam as follows:
  - a. If the contacts are open, rotate the cam counterclockwise until the R-B contacts close.
  - b. If the contacts are closed, rotate the cam clockwise until the R-B contacts open.
8. Check for proper auxiliary equipment differential and switching by driving the motor through the full stroke in both directions.
9. Disconnect the potentiometer, reconnect the controller, and replace the motor top cover.

NOTE: Changing the differential from 1° to 10° reverses the switching action. For example, with a 10° differential, switch contacts R-B make and R-W break on a counterclockwise (closed) rotation. With a 1° differential, switch contacts R-W make and R-B break on a counterclockwise (closed) rotation.

## OPERATION

Use Series 90 Modutrol IV Motors for standard Series 90 operation (see Table 6):

1. Two potentiometers, one in the controller and one in the motor, along with the motor resistor network, form a bridge circuit. As long as the value of the controlled medium remains at the setpoint, the circuit remains balanced and the motor does not run.
2. When the controlled medium value changes, the controller potentiometer wiper moves, unbalancing the bridge circuit.
3. The imbalance is amplified and energizes switching to drive the motor in the direction necessary to correct the controlled medium change.
4. As the motor shaft rotates, it turns the feedback potentiometer, rebalancing the bridge circuit, stopping the motor.

Table 6. Modutrol IV Motor Operation.

Motor Type	Signal	Resulting Action
Non-Spring Return or Spring Return	Open W and short R to B	drives open
	Open B and short R to W	drives closed
	Jumper R-W-B	drives to midstroke
	None	stops (none)
Non-Spring Return	Power Loss	
Spring Return	Power Loss	spring returns (closed)

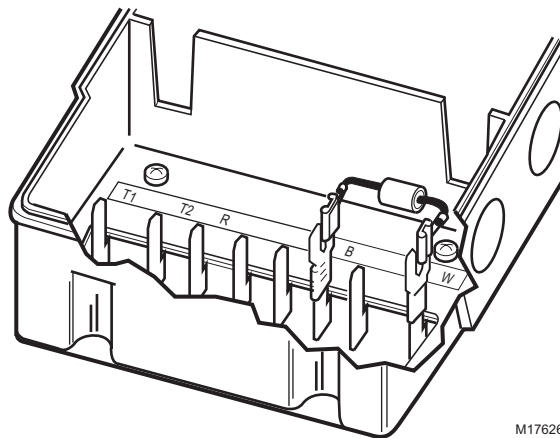

M17626

Fig. 10. Attaching a shunt resistor to TRADELINE motors.

Table 7. Cam Arrangements.

Motor	Inner Cam	Outer Cam
M9164D1009, M9174D1007	Red	Blue
M9175D1014		
M9172W1004	Red	Red
ALL OTHER M9164, M9172, M9175	Blue	Red
M9161, M9171		
M9184, M9194		
M9185, M9186		
M9484, M9494	Blue	Blue
ALL OTHER M9174		

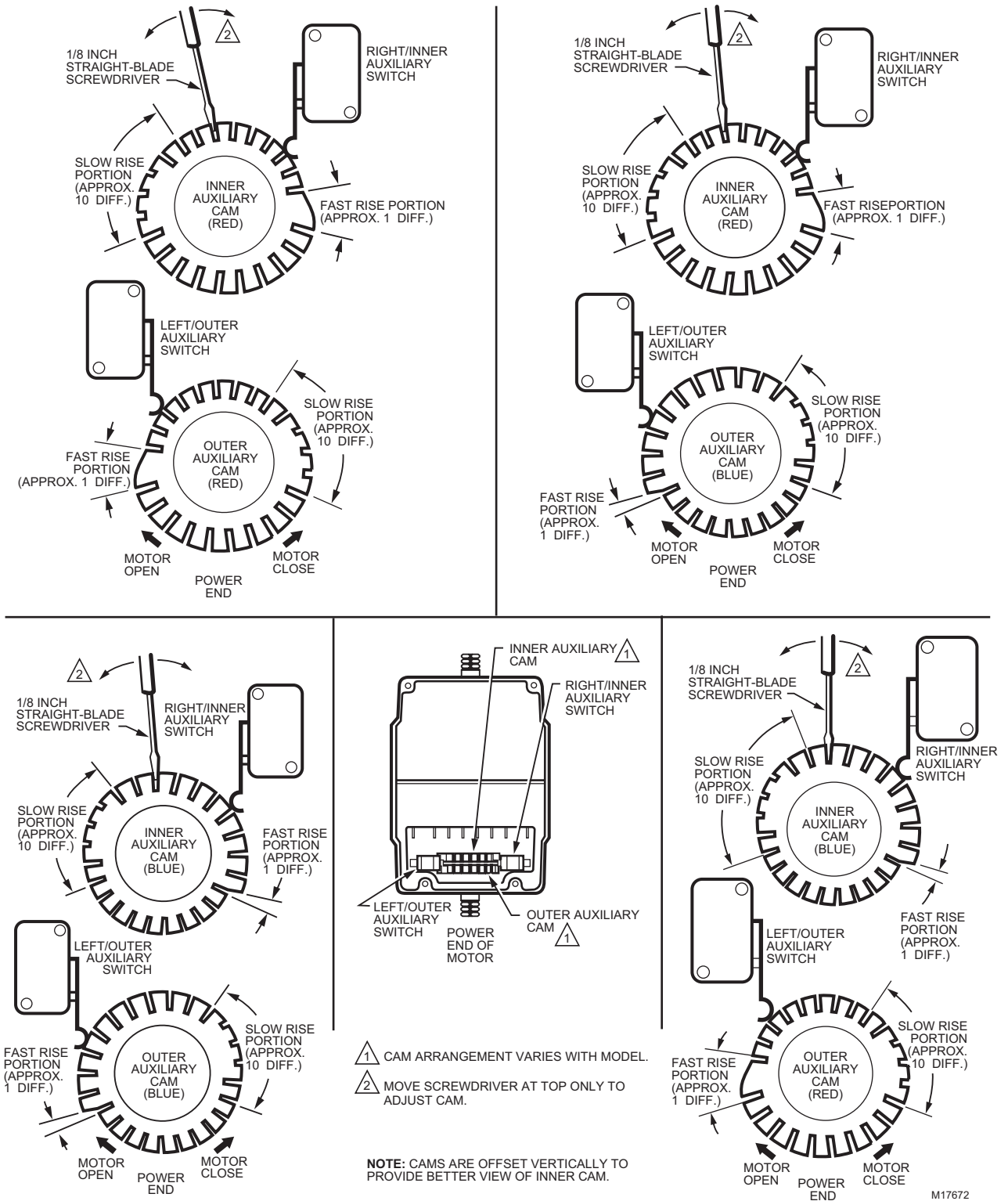

Fig. 11. Auxiliary switch adjustment.

## CHECKOUT

After the installation and linkage adjustment, check the entire motor and control hookup. Proper checkout ensures that:

- The motor operates the load (damper or valve) properly.
- The motor responds properly to the controller as the input varies. See Table 6.
- The auxiliary switch, if used, operates at the desired point of motor rotation.

1. Inspect motor, linkage, and valve or damper to ensure all mechanical connections are correct and secure.

**NOTE:** In damper installations, the pushrod should not extend more than a few inches past the ball joints.

2. Ensure that there is adequate clearance for the linkage throughout the entire motor stroke without binding or striking other objects.
3. Ensure the motor transformer is properly sized.

**NOTE:** If a common transformer is used to power multiple motors, ensure the power input is in phase with all motors.

4. Drive the motor fully open and fully closed. See Table 6.

**NOTE:** Refer to controller or system instructions for additional checkout procedures.

5. For spring return motors, ensure that the valve or damper returns to normal position upon power interruption.
6. Return the controller to the desired setting before leaving the job.

## REPLACEMENT

### Damper Application

1. Turn off power and remove wiring from the old motor.
2. Remove the crank arm from shaft of old motor and remove the old motor.
3. Determine necessity of the mounting bracket. If the linkage can reach the new motor shaft position and the crank arm has clearance for the necessary rotation, the bracket is not required. Use the 220738A Adapter Bracket or the 221455A Crank Arm if the crank arm must rotate through the bottom plane of the motor.
  - a. If no bracket is required, mount the new motor directly to the equipment and refer to the Installation, Settings and Adjustments, and the Operation and Checkout sections of these instructions.
  - b. If the bracket is required, refer to the Adapter Bracket section and Fig. 3 in addition to the Installation, Settings and Adjustments, and the Operation and Checkout sections of these instructions.
4. Use No. 12 or 1/4 inch machine screws or bolts to mount the new motor.
5. Mount damper crank arm and linkage to the new motor shaft.
6. Use the Checkout procedures to test the crank arm and linkage adjustment.

### Valve Application

When replacing a motor in a valve application, the linkage determines the necessity of the 220738A Adapter Bracket. With Q100, Q601 or Q618 Linkages, it is necessary to use the 220738A to raise the motor shaft to the appropriate height. Valve applications with a Q5001 Linkage do not require the 220738A Adapter Bracket. To operate Honeywell V5011 two-way or V5013 three-way valves through full stroke, use a 160° stroke motor.