



Actuators LKS Series



Серво приводы серии LKS для управления воздушными заслонками в газо-горелочных устройствах

Тип / серия	 <p>LKS 118</p>	 <p>LKS 131</p>	 <p>LKS 160</p>	 <p>LKS 170</p>	 <p>LKS 310</p>
Применение	Для маленьких горелок с простым регулированием воздушной заслонки (открыто / закрыто)	Для 1 или 2-х ступенчатых жидко-топливных или газовых горелок с или без полного закрытия заслонки	Для воздушных заслонок применяемых на многоступенчатых и модулирующих горелках с полным закрытием заслонки	Для воздушных заслонок применяемых на многоступенчатых и модулирующих горелках с полным закрытием заслонки	Для воздушных заслонок с большим усилием или промышленного применения
Время поворота на 90° / Усилие Нм	5 сек. / 0,6Нм	5 сек. / 0,6 Нм 15 сек. / 0,6 Нм 38 сек. / 0,6 Нм	3 сек. / 1,5 Нм 5 сек. / 2,5 Нм 8 сек. / 3,0 Нм 12 сек. / 3,0 Нм 22 сек. / 3,0 Нм 34 сек. / 3,0 Нм 45 сек. / 3,0 Нм 65 сек. / 3,0 Нм	5 сек. / 1,2 Нм 10 сек. / 1,2 Нм 13 сек. / 2,4 Нм 15 сек. / 2,4 Нм 26 сек. / 2,8 Нм 30 сек. / 2,8 Нм	3,5 сек. / 3,5 Нм 7 сек. / 7,0 Нм 10 сек. / 10,0 Нм 15 сек. / 15 Нм 30 сек. / 15 Нм
Макс. кол-во кулачков	2	7	7	5	7
Шток	10мм шестиугольный шток или 6мм круглый шток расплюснутый до 5мм	четыреугольный шток 8x8мм	круглый шток 8мм, расплюснутый до 7мм или шестиугольный шток	четыреугольный шток 8x8мм	круглый шток 10мм, расплюснутый до 8мм
Электрическое соединение	поставляется с кабелем	поставляется с кабелем и коннектором	Мульти-полюсный терминал	поставляется с кабелем и коннектором	Мульти-полюсный терминал
Наличие потенциометра	нет	Да, с дополнительным набором и в зависимости от конфигурации кулачков	Да, с дополнительным набором и в зависимости от конфигурации кулачков	Да, с дополнительным набором	По запросу
					

The LKS Series Servo Motors are for general use for combustion air dampers

					
Type /Series	LKS 118	LKS 131	LKS 160	LKS 170	LKS 310
Application	For small burners with simple air damper control (open / close)	For 1- or 2-stage oil and gas burners with or without fully closing damper	For air dampers on multi stage or modulating oil and gas burners with fully closing damper.	Direct coupled, air dampers on multi stage or modulating oil and gas burners with fully closing damper.	For air dampers with higher torque or industrial applications
Drive time for 90° stroke / Torque Nm	5 seconds / 0.6 Nm	5 seconds / 0.6 Nm 15 seconds / 0.6 Nm 38 seconds / 0.6 Nm	3 seconds / 1.5 Nm 5 seconds / 2.5 Nm 8 seconds / 3.0 Nm 12 seconds / 3.0 Nm 22 seconds / 3.0 Nm 34 seconds / 3.0 Nm 45 seconds / 3.0 Nm 65 seconds / 3.0 Nm	5 seconds / 1.2 Nm 10 seconds / 1.2 Nm 13 seconds / 2.4 Nm 15 seconds / 2.4 Nm 26 seconds / 2.8 Nm 30 seconds / 2.8 Nm	3.5 seconds / 3.5 Nm 7 seconds / 7.0 Nm 10 seconds / 10.0 Nm 15 seconds / 15.0 Nm 30 seconds / 15.0 Nm
Max. possible cams	2	7	7	5	7
Shaft	10 mm hexagonal shaft or couples to 6 mm round shaft flattened to 5 mm	Couples to square shaft 8 x 8 mm	Round shaft 8 mm, flattened to 7 mm or hexagonal shaft 8 mm	Couples to square shaft 8 x 8 mm	Round shaft 10 mm, flattened to 8 mm
Electrical connection	Provided with cable	Provided with cable and plug	Multi-pole terminal block	Provided with cable and plug	Multi-pole terminal block
Add-on potentiometer	No	Yes, with add-on kit and dependent on cam-configuration	Yes, with add-on kit and dependent on cam-configuration	Yes, with add-on kit	On request
					

ACTUATOR

LKS 170

FOR AIR DAMPERS ON SINGLE, DUAL STAGE AND
MODULATING BURNERS

PRODUCT HANDBOOK



APPLICATION

The LKS 170 air damper actuator is designed to be fitted to multi-stage or modulating oil and gas burners with fully closed position.

CONTENTS

GENERAL

Description	2
Features	2

TECHNICAL DATA

Specification	3
Dimensional drawings	4

INSTALLATION AND OPERATION

Installation and final checkout	5
Circuit diagrams	7

VARIOUS

Standards and approvals	7
Ordering information	7
Accessories	7

GENERAL

DESCRIPTION

A synchronous motor powers an output shaft and a cam shaft via a gear reducer.

The cam shaft operates limit and auxiliary switches. The

position at which one of the limit or auxiliary switches operates can be adjusted steplessly within the operating range using the associated cam disc. Spindle-driven cams, which can be adjusted with a screwdriver, are available.

FEATURES

Electric actuator up to 2.8 Nm

- **Drive times: 5 ... 30 sec.**
- **Variants:** - clockwise or counter clockwise rotation
- with integrated electronic circuitry
- shaft version
- **Output shaft, can be decoupled**
- **Particularly slim housing, output perpendicular to the housing**
- **Position indicator**
- **Easily adjustable limit and auxiliary switches**
- **Synchronous motor**

TECHNICAL DATA

SPECIFICATION

Type overview

Clockwise rotation ¹⁾

Diagram 2)	Shaft 3)	Drive time 4)	Load torque 5)	Holding torque	Voltage 6)	Type	Remarks
Nr.	Nr.	s	Nm	Nm	V		
S2	1	13	2,4	1,3	230	LKS 170-06 A 1-13 S2	
S2	1	5	1,2	1,0	230	LKS 170-07 A 1-5 S2	
S3	1	5	1,2	1,0	230	LKS 170-08 A 1-5 S3	

Counter-clockwise rotation ¹⁾

Diagram 2)	Shaft 3)	Drive time 4)	Load torque 5)	Holding torque	Voltage 6)	Type	Remarks
Nr.	Nr.	s	Nm	Nm	V		
S2	1	5	1,2	1,0	230	LKS 170-02 B 1-5 S2	
S2	1	13	2,4	1,3	230	LKS 170-11 B 1-13 S2	
S3	1	5	1,2	1,0	230	LKS 170-12 B 1-5 S3	

Legend

- 1) when viewing from direction A (see dimensional drawing)
- 2) see "Circuit diagrams"
- 3) see "Dimensional drawing"
- 4) at 50 Hz for 90°
at 60 Hz, Drive times are about 20 % shorter

- 5) under nominal conditions
under extreme conditions (e.g. +60 °C, 230V -15%) the torques will be 25% lower
- 6) +10% -15%; 50...60Hz
at -15%; torque reduced by approx. 20% at undervoltage

Technical Data

Housing

- impact-proof, heat-resistant synthetic material
Colour: black

Drive motor

- reversible synchronous motor

Clutch

- the gear can be separated from the engine by turning a 3mm Allen key 30°.

Switch point setting

- via stepless cam setting, spindle-driven cam with superimposed scale

Position indicator

- via co-rotation scale

Connection system

- fixed cable connection with 9-in plug, cable outlet either straight or from the side

Gearing

- spur gearing, maintenance-free

Drive shaft

- Standard plastic, interior square 8 mm, output shaft is perpendicular to the device

Fitting and fastening

- fastened with 2 M 5 screws

PCBs

- for all electrical functions, increased conductor thickness

Mains voltage

- 230 V -15% +10%

Mains frequency

- 50 Hz or 60 Hz

Safety class

- II VDE 0631

Power consumption

- approx. 9 VA

Duty cycle

- 50% in 2 minutes

Interference suppression

- N (according to VDE 0785)

Actuating angle

- max. 90°

Mounting position

- any

Protection

- IP 00, housing partly open via snap hook (DIN 40050)

Cable connection

- via 9 pin AMP socket connector

Direction of rotation

- see "Type overview"

Torque and holding torque

- see "Type overview"

Drive times

- 5, 10, 13, 15, 26, 30 sec for 90°

Limit and auxiliary switches

- max. 5 operation with adjustable cam discs, cams coloured in normal way:
 - blue fully closed position
 - orange low load
 - red high load
 - black spare switches for additional functions
- switching voltage AC 24...230 V
- switching capacity with inductive loads 250 VA

Ambient temperature

- operation 0 ... +60° C
- transport and storage -20 ... +60° C

Condensation, icing and exposure to water not permitted

Weight

- approx. 500 g

DIMENSIONAL DRAWING

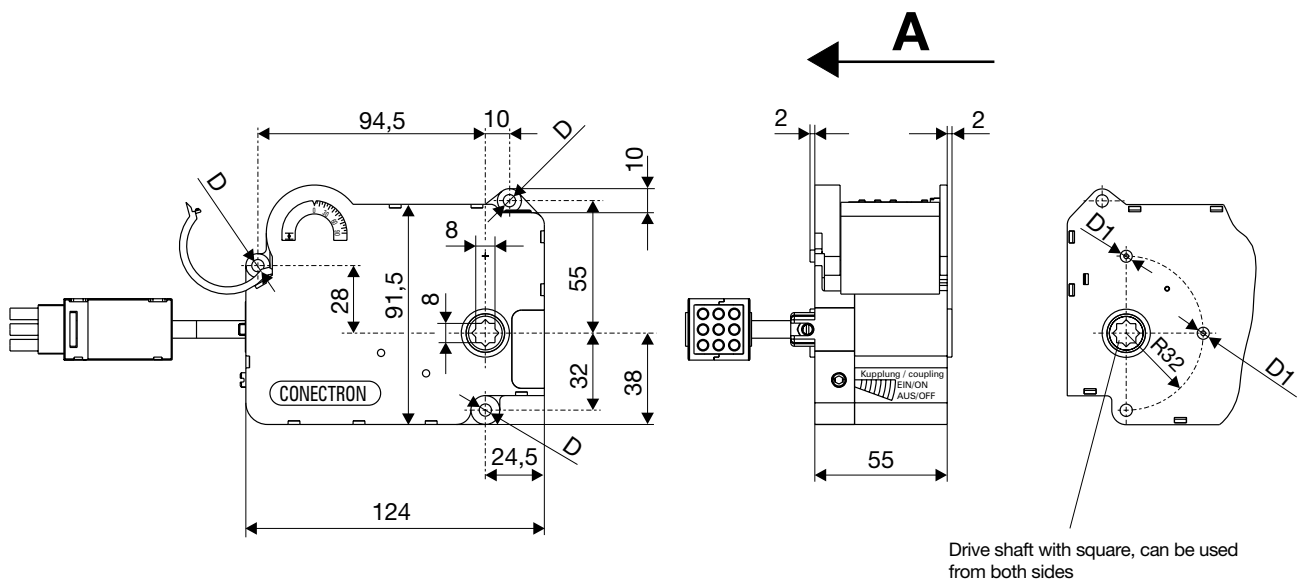

D) Fixing hole through-hole 5,1 mm inside dia

D1) Centering burrs 5,0 mm inside dia

INSTALLATION AND OPERATION

INSTALLATION AND FINAL CHECKOUT

- The regulations and standards applicable in each particular case must be observed.
- Installation and commissioning must only be carried out by qualified technicians.
- Electrical wiring must comply with national and local regulations.
- Always lay the burner ignition cable separately and as remotely as possible from the device and other cables.
- Carefully check all cabling and wiring prior to commissioning.
- Disconnect the actuators completely from the power supply when working close to terminals and connections.
- Screw the housing cover securely in place to provide shock-hazard protection on the actuator and all electrical connections.
- Electromagnetic emissions must be checked on a case by case basis.

CIRCUIT DIAGRAMS

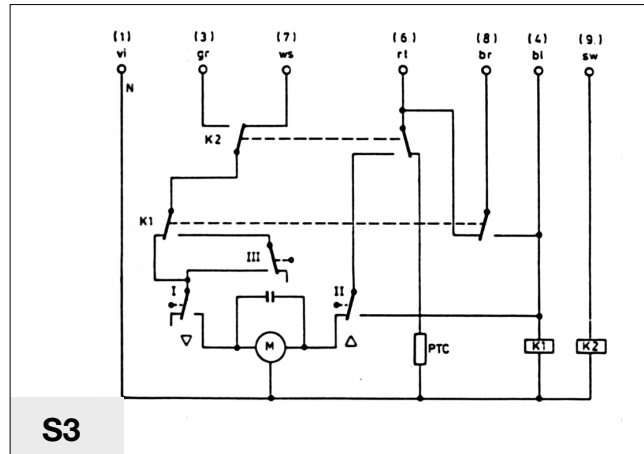
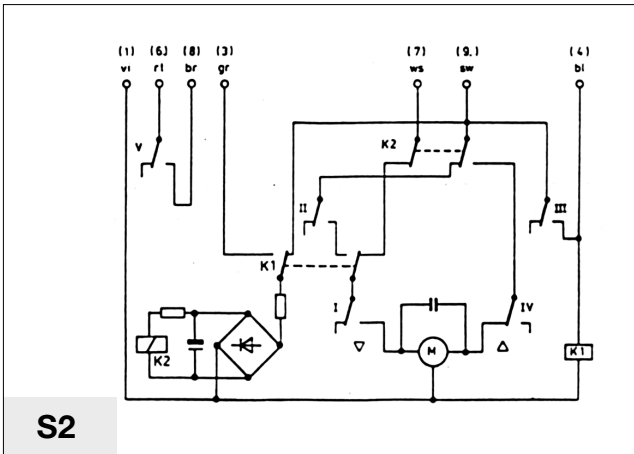

VARIOUS

STANDARDS AND APPROVALS

Conformity

- In accordance with EU Directives 73/23/EU and 93/68/EU. Conforms to EN 60730 – 1 : 1991 A1 and A11 : 1991 EN 60730 – 2 – 5 : 1991

ORDERING INFORMATION

Not for creation of new type

LKS 170-02 B 1 - 5 S2

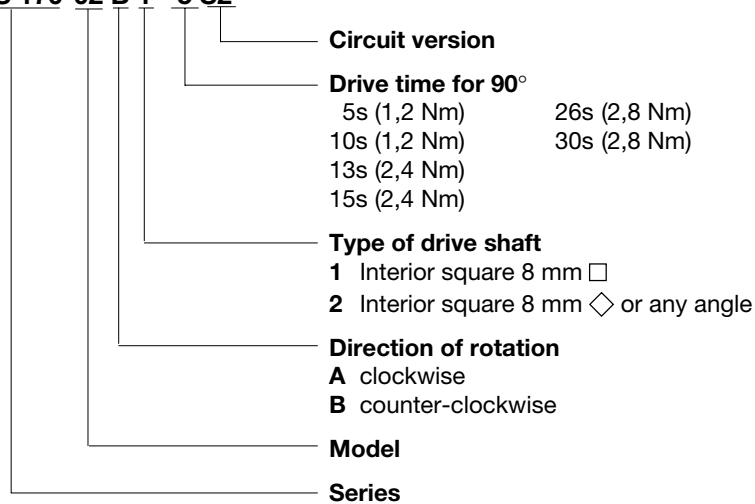

ACCESSORIES

Potentiometer - retrofit set can be supplied as an insert, Ohmic value approx. 1k at an angle of rotation of 90° on the output shaft.

Cable length approx. 50 cm.

Order no: ZPN 170 - 01

Honeywell

Honeywell Burner & Boiler Control Europe

Satronic AG

Honeywell-Platz 1

CH-8157 Dielsdorf

Switzerland

Phone +41 1 855 22 11

Fax +41 1 855 22 22

ACTUATOR

LKS 160

FOR AIR DAMPERS ON MULTI-STAGE AND
MODULATING BURNERS

PRODUCT HANDBOOK



APPLICATION

The LKS 160 air damper actuator is designed to be fitted to multi-stage or modulating oil and gas burners with fully closed position.

CONTENTS

GENERAL

Description	2
Features	2

TECHNICAL DATA

Specification	3
Dimensional drawings	5

INSTALLATION AND OPERATION

Installation and final checkout	6
Circuit diagrams	7

VARIOUS

Standards and approvals	9
Ordering information	9
Accessories	9

GENERAL

DESCRIPTION

A synchronous motor powers a drive shaft and a backlash-free cam shaft via a gear reducer.

The cam shaft operates limit and auxiliary switches. The position at which one of the limit or auxiliary switches operates

can be adjusted steplessly within the operating range using the associated cam disc. Manually adjustable lever-operated cams or spindle-driven cams, which can be adjusted with a screwdriver, are available.

FEATURES

Electric actuator up to 3.0 Nm

• **Drive times: 3 ... 65 sec.**

• **Variants:** - clockwise or counter clockwise rotation
- with integrated electronic circuitry
- shaft version

• **Position indicator**

• **Easily adjustable limit and auxiliary switches**

• **Synchronous motor**

TECHNICAL DATA

SPECIFICATION

Type overview

clockwise rotation ¹⁾

Diagram ²⁾	Shaft ³⁾	Drive time ⁴⁾	Load torque ⁵⁾	Holding torque	Voltage ⁶⁾	Type	Remarks ⁷⁾
Nr.	Nr.	s	Nm	Nm	V		
S1	5	5	2,5	0,8	230	LKS 160-01 A 5-5 S1	standard version
S2	5	5	2,5	0,8	230	LKS 160-03 A 5-5 S2	standard version
S1	5	12	3	1,5	230	LKS 160-07 A 5-12 S1	
S1	5	5	2,5	0,8	230	LKS 160-09 A 5-5 S1	Spindle-driven cam
S7	5	30	3	3	24	LKS 160-22 A 5-30 S7	
S7.1	5	30	3	3	110	LKS 160-24 A 5-30 S7.1	
S6	5	34	3	3	230	LKS 160-25 A 5-34 S6	
S1.2	5	34	3	3	230	LKS 160-26 A 5-34 S1.2	
S1	5	12	3	1,5	230	LKS 160-37 A 5-12 S1	
S4	5	5	2,5	0,8	230	LKS 160-39 A 5-5 S4	
S2	5	3	1,5	0,6	230	LKS 160-40 A 5-3 S2	
S13	5	45	3	3	230	LKS 160-42 A 6-45 S13	Spindle-driven cam
S8.P1.1	5	34	3	3	230	LKS 160-44 A 5-34 S8.P1.1	Potentiometer can be retrofitted
S8.P2	5	30	3	3	110	LKS 160-55 A 5-30 S8.P2	Potentiometer can be retrofitted
S8.P4	5	45	3	3	230	LKS 160-59 A 5-45 S8.P4	with Potentiometer, special circuit
S8.P	6	34	3	3	230	LKS 160-63 A 6-34 S8.P	Potentiometer can be retrofitted
S8.P4.1	5	38	3	3	120	LKS 160-65 A 5-38 S8.P4.1	Run time at 60 Hz, with Potentiometer, special circuit
S8.P3	5	30	3	3	24	LKS 160-67 A 5-30 S8.P3	Potentiometer can be retrofitted
S8.P1.1	5	34	3	3	230	LKS 160-68 A 5-34 S8.P1.1	Potentiometer can be retrofitted, spindle-driven cam
S8.P1	5	5	2,5	0,8	230	LKS 160-70 A 5-5 S8.P1	
S4	5	3	1,5	0,6	230	LKS 160-73 A 5-3 S4	
S15	5	5	2,5	0,8	230	LKS 160-75 A 5-5 S15	For 3-stage operation
S2	5	12	3	1,5	230	LKS 160-79 A 5-12 S2	

Legend

- | | |
|--|---|
| <p>1) when viewing from direction A (see dimensional drawing)</p> <p>2) see "Circuit diagrams"</p> <p>3) see "Dimensional drawing"</p> <p>4) at 50 Hz for 90°
at 60 Hz, Drive times are about 20 % shorter</p> | <p>5) under nominal conditions
under extreme conditions (e.g. +60 °C, 230V -15%) the torques will be 25% lower</p> <p>6) +10% -15%; 50...60Hz
at -15%; torque reduced by approx. 20% at undervoltage</p> <p>7) Standard: Lever-operated cam</p> |
|--|---|

counter-clockwise rotation¹⁾

Diagram 2)	Shaft 3)	Drive time 4)	Load torque 5)	Holding torque	Voltage 6)	Type	Remarks 7)
Nr.	Nr.	s	Nm	Nm	V		
S1	5	5	2,5	0,8	230	LKS 160-02 B 5-5 S1	standard version
S2	5	5	2,5	0,8	230	LKS 160-04 B 5-5 S2	standard version
S1	5	3	1,5	0,6	230	LKS 160-08 B 5-3 S2	
S1	5	5	2,5	0,8	230	LKS 160-10 B 5-5 S1	
S2	5	3	1,5	0,6	230	LKS 160-12 B 5-3 S2	
S6	5	34	3	3	230	LKS 160-18 B 5-5 S2	
S2.1	5	5	2,5	0,8	230	LKS 160-19 B 5-5 S2.1	Shaft with adapter
S3.2	5	5	2,5	0,8	110	LKS 160-28 B 5-5 S3.2	
S4	5	5	2,5	0,8	230	LKS 160-36 B 5-5 S4	
S13	6	34	3	3	230	LKS 160-43 B 6-34 S13	Spindle-driven cam
S2	5	12	3	1,5	230	LKS 160-50 B 5-12 S2	
S4	5	5	2,5	0,8	230	LKS 160-51 B 5-5 S4	
S2	5	8	3	1,5	230	LKS 160-52 B 5-8 S2	Other cam colours
S8.P1	5	12	3	1,5	230	LKS 160-57 B 5-12 S8.P1	Potentiometer can be retrofitted
S4	5	12	3	1,5	230	LKS 160-60 B 5-12 S4	
S6	5	5	2,5	0,8	230	LKS 160-61 B 5-5 S6	
S8.P1.1	5	34	3	3	230	LKS 160-69 B 5-34 S8.P1.1	
S6.1	5	5	2,5	0,8	110	LKS 160-71 B 5-5 S6.1	
S4.9	5	5	2,5	0,8	230	LKS 160-74 B 5-5 S4.9	Relays control 24 VDC
S6.2	5	65	3	3	230	LKS 160-76 B 5-65 S6.2	
S8.P1	5	5	2,5	0,8	230	LKS 160-77 B 5-5 S8.P1	Potentiometer can be retrofitted
S12	5	30	3	3	230	LKS 160-78 B 5-30 S10	Face down

Legend

- | | |
|--|---|
| 1) when viewing from direction A (see dimensional drawing) | 5) under nominal conditions |
| 2) see "Circuit diagrams" | under extreme conditions (e.g. +60 °C, 230V -15%) the torques will be 25% lower |
| 3) see "Dimensional drawing" | +10% -15%; 50...60Hz |
| 4) at 50 Hz for 90° | at -15%; torque reduced by approx. 20% at undervoltage |
| at 60 Hz, Drive times are about 20 % shorter | 7) Standard: Lever-operated cam |

Technical Data

Housing

- impact-proof, heat-resistant synthetic material
Colour: black

Drive motor

- reversible synchronous motor

Switch point setting

- stepless cam setting, lever-operated or spindle-driven
cams; if spindle-driven, with superimposed scale

Position indicator

- scale

Connection system

- terminal blocks

Gearing

- spur gearing, maintenance-free

Drive shaft

- steel

Fitting and fastening

- Fastened from inside via tapped M 5 through-holes

PCBs

- for all electrical functions, increased conductor thickness

Mains voltage

- 230 V -15% +10% or
110 V -15% +10%

Mains frequency

- 50 Hz or 60 Hz

Safety class

- II VDE 0631

Power consumption

- approx. 4 VA

Duty cycle

- depending on motor, 50 to 70 % in 2 minutes

Interference suppression

- N (according to VDE 0785)

Actuating angle

- max. 90°

Mounting position

- any

Protection

- IP 44, assuming appropriate cable entries and screw fastening (DIN 40050)

Cable entries

- 2 x PG9

Cable connection

- terminal block for 0.5 mm² (min.) and 2.5 mm² (max.) wire cross-section

Direction of rotation

- see "Type overview"

Torque and holding torque

- see "Type overview"

Drive times

- 3 to 65 sec for 90°

Limit and auxiliary switches

- max. 7 operation with adjustable cam discs, cams coloured in normal way:
 - blue fully closed position
 - orange low load
 - red high load
 - black spare switches for additional functions
- switching voltage AC 24...230 V
- switching capacity with inductive loads 250 VA

Ambient temperature

- operation 0 ... +60° C
- transport and storage -20 ... +60° C

Condensation, icing and exposure to water not permitted

Weight

- approx. 610g

DIMENSIONAL DRAWING

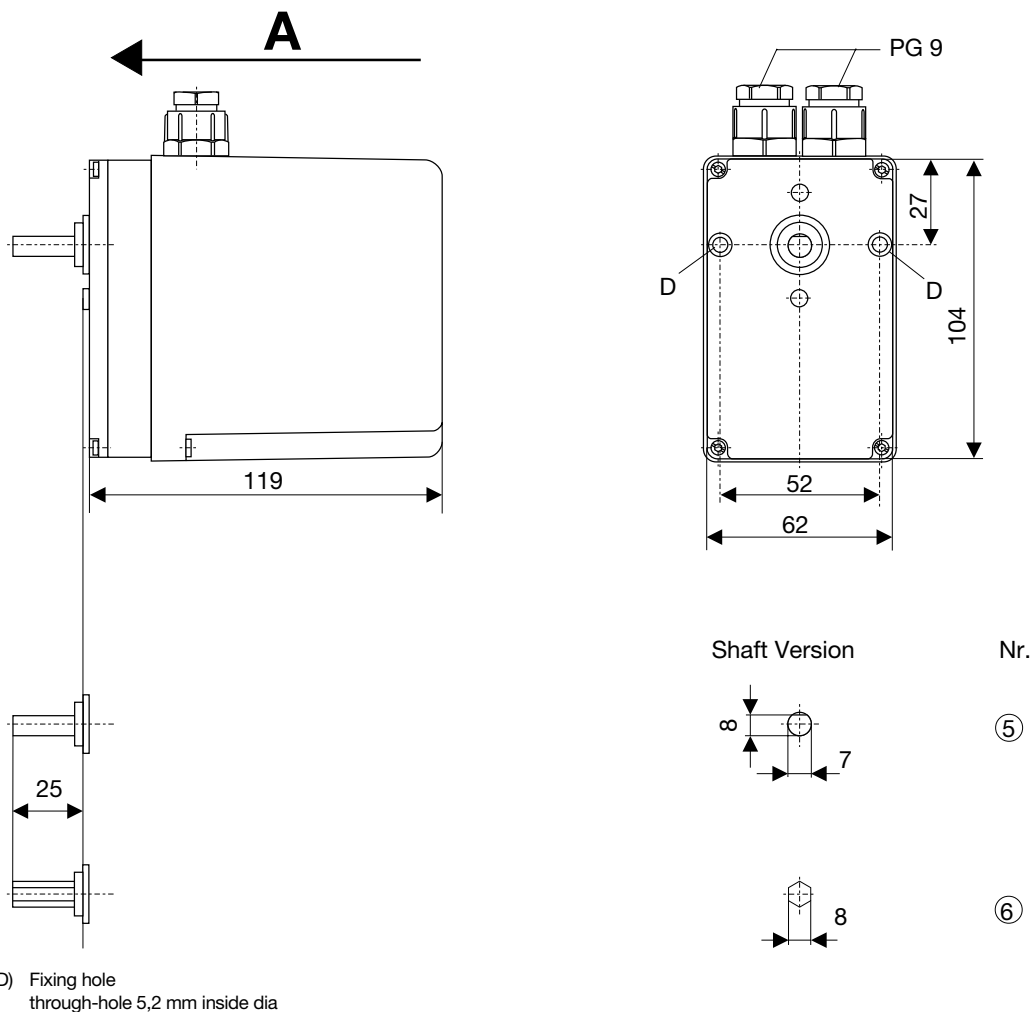

INSTALLATION AND OPERATION

INSTALLATION AND FINAL CHECKOUT

- The regulations and standards applicable in each particular case must be observed.
- Installation and commissioning must only be carried out by qualified technicians.
- Electrical wiring must comply with national and local regulations.
- Always lay the burner ignition cable separately and as remotely as possible from the device and other cables.
- Carefully check all cabling and wiring prior to commissioning.
- Disconnect the actuators completely from the power supply when working close to terminals and connections.
- Screw the housing cover securely in place to provide shock-hazard protection on the actuator and all electrical connections.
- Electromagnetic emissions must be checked on a case by case basis.

CIRCUIT DIAGRAMS

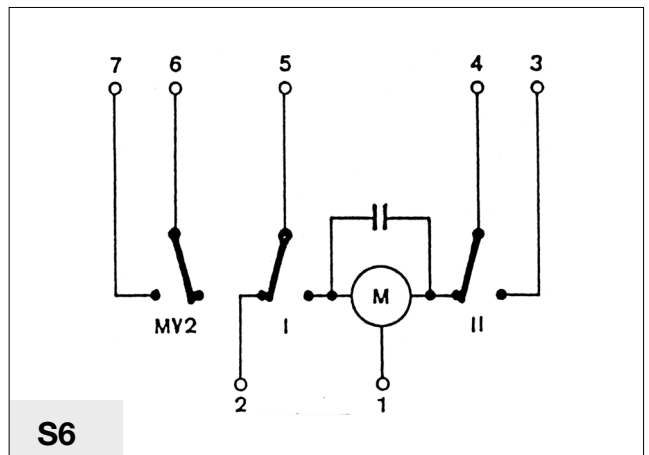
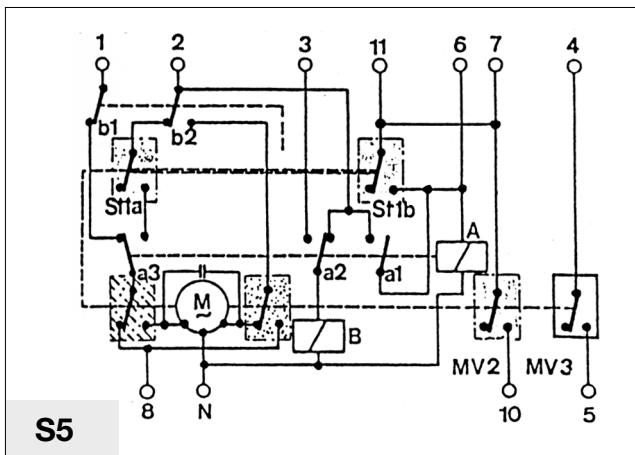
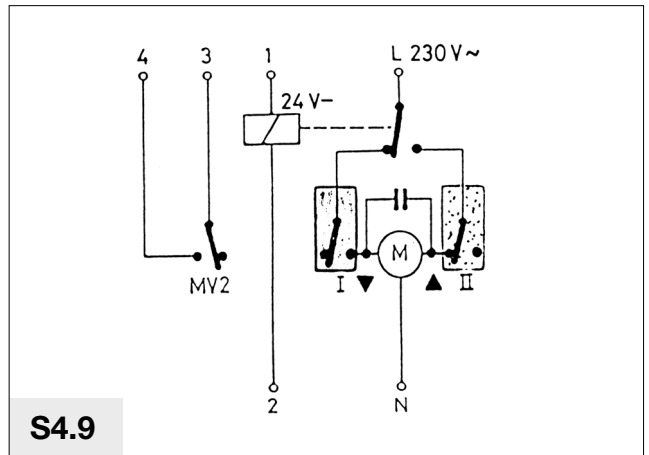
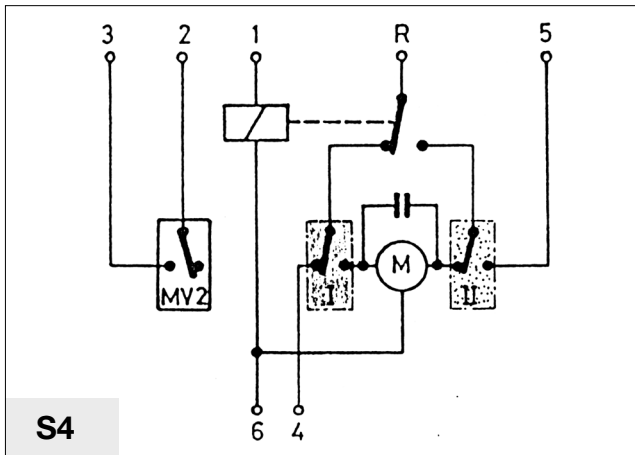
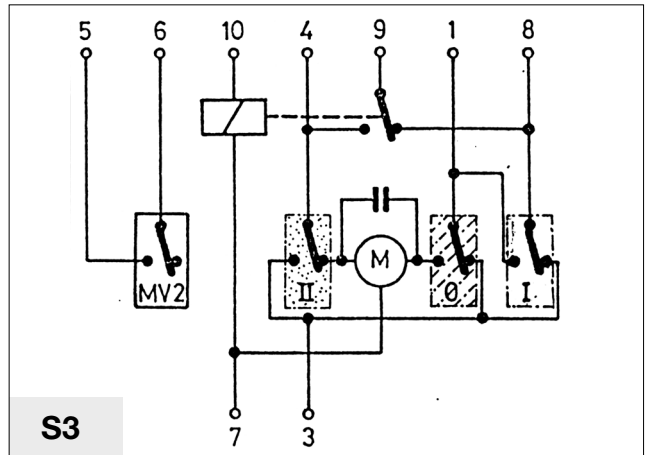
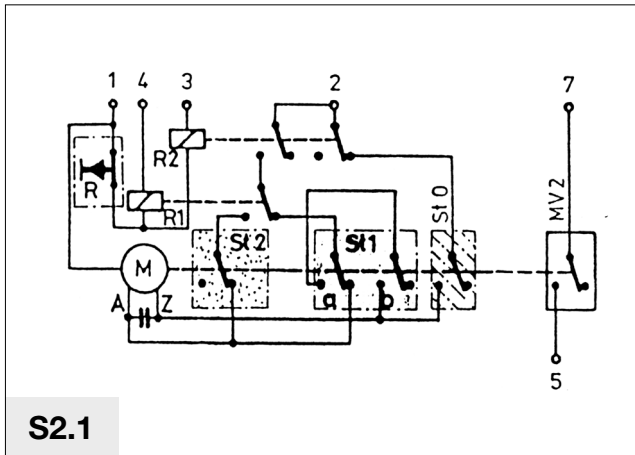
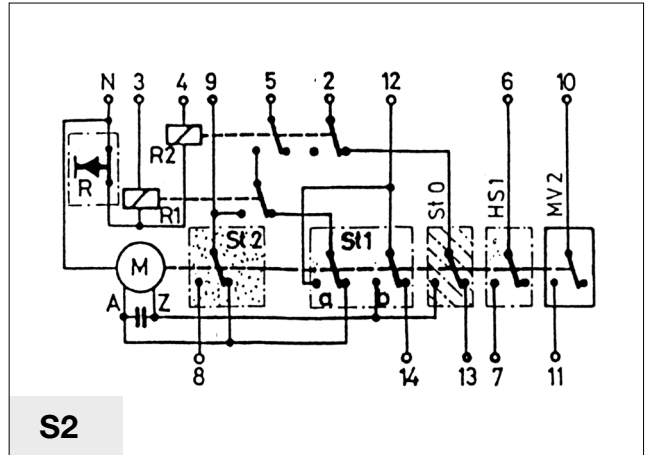
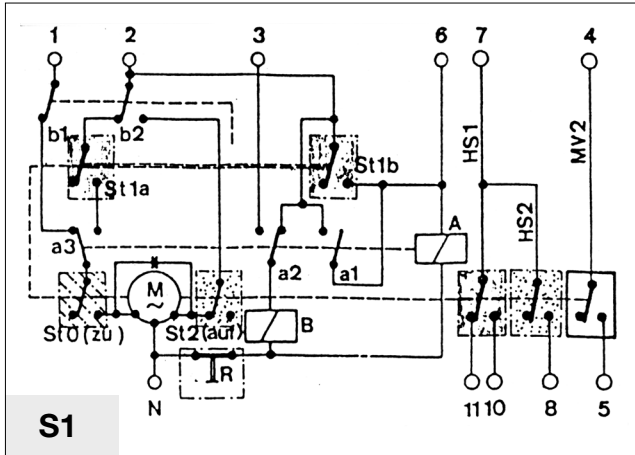

CIRCUIT DIAGRAMS

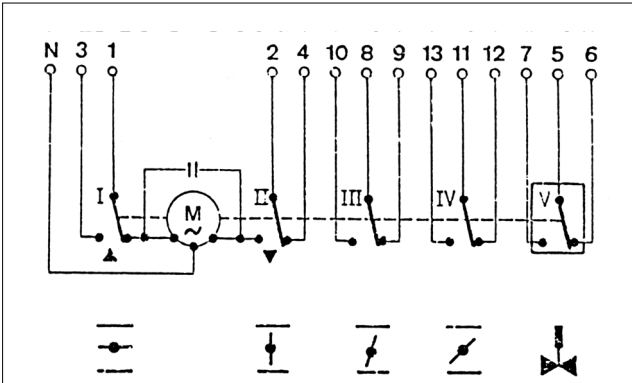

S8.P

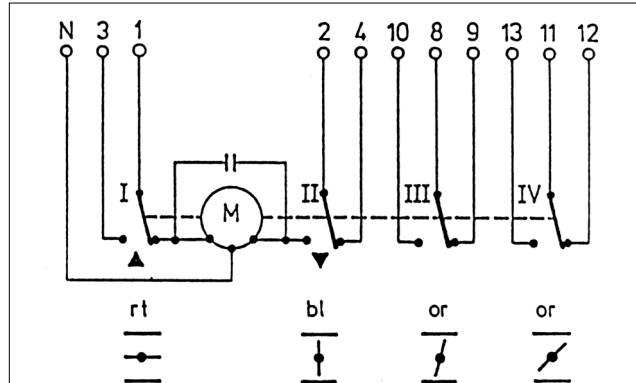

S8.P1

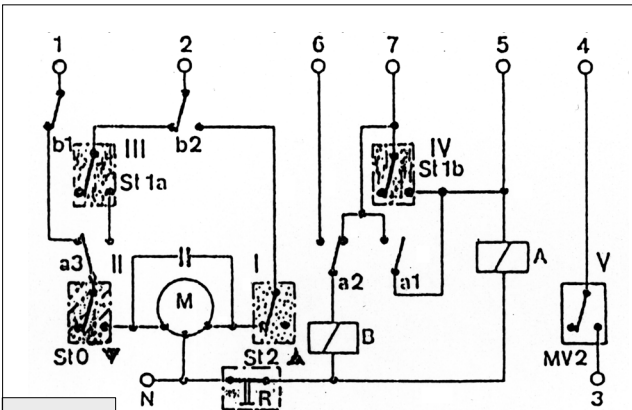

S9

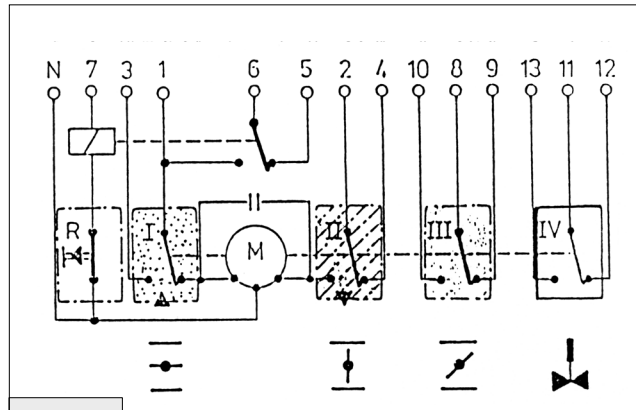

S10

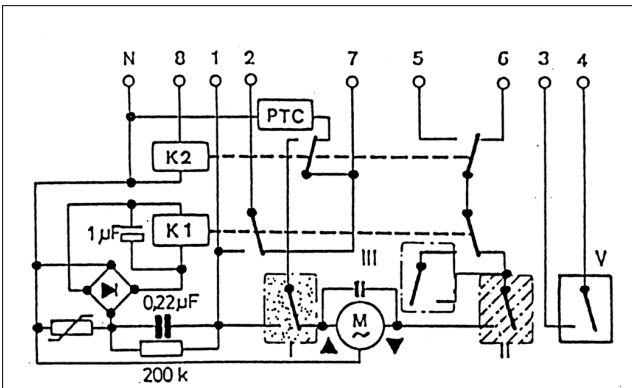

S11

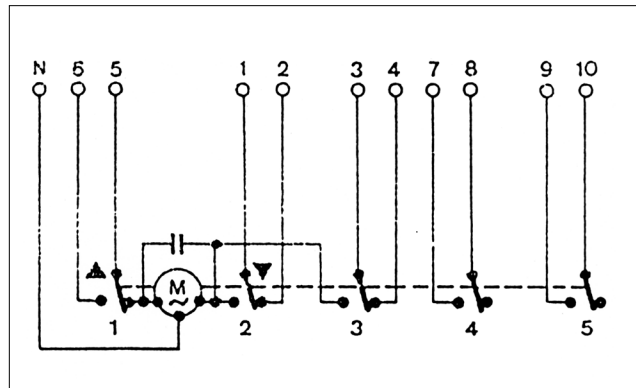

S12

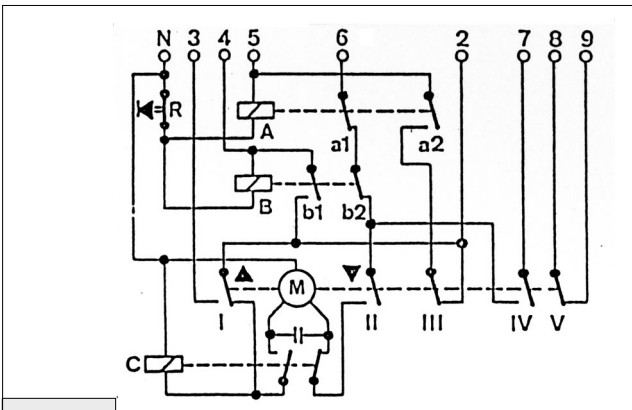

S13

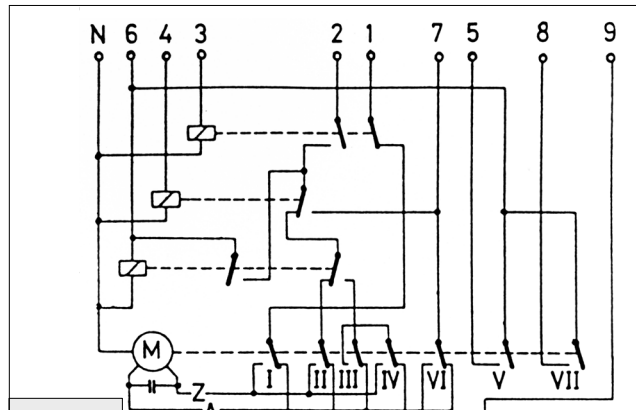

S15

VARIOUS

STANDARDS AND APPROVALS

Conformity

- In accordance with EU Directives 73/23/EU and 93/68/EU. Conforms to EN 60730 – 1 : 1991 A1 and A11 : 1991 EN 60730 – 2 – 5 : 1991

ORDERING INFORMATION

Not for creation of new type

LKS 160-09 B 5 - 30 S3.P1.1

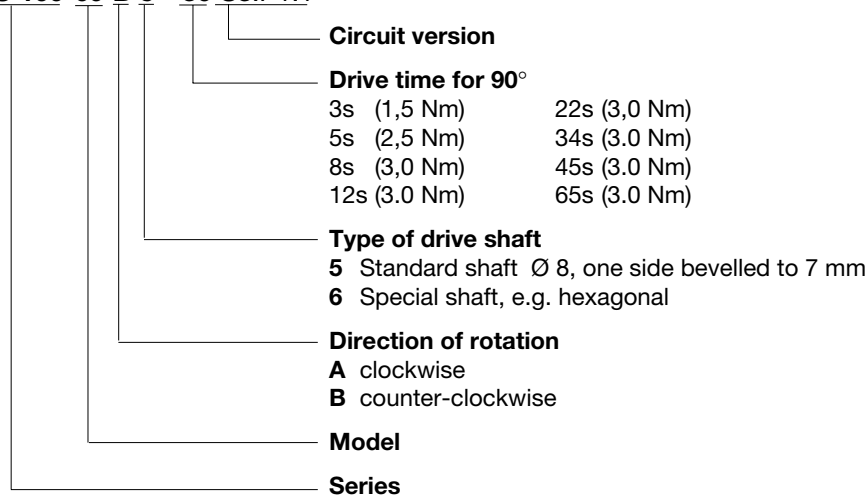

ACCESSORIES

Potentiometer - retrofit set for actuators without relays
(90° = ca 1kΩ) **ZPN 160-01**

Potentiometer - retrofit set for actuators with relays
(90° = ca 1kΩ) **ZPN 160-06**

Other versions on request

Honeywell

Honeywell Burner & Boiler Control Europe

Satronic AG

Honeywell-Platz 1

CH-8157 Dielsdorf

Switzerland

Phone +41 1 855 22 11

Fax +41 1 855 22 22

ACTUATOR

LKS 131

FOR AIR DAMPERS ON SINGLE, DUAL STAGE AND
MODULATING BURNERS

PRODUCT HANDBOOK



APPLICATION

The LKS 131 air damper actuator is designed to be fitted to multi-stage or modulating oil and gas burners with fully closed position.

CONTENTS

GENERAL

Description	2
Features	2

TECHNICAL DATA

Specification	3
Dimensional drawings	4

INSTALLATION AND OPERATION

Installation and final checkout	5
Circuit diagrams	6

VARIOUS

Standards and approvals	7
Ordering information	7
Accessories	7

GENERAL

DESCRIPTION

A synchronous motor powers an output shaft and a backlash-free cam shaft via a gear reducer.

The cam shaft operates limit and auxiliary switches. The

position at which one of the limit or auxiliary switches operates can be adjusted steplessly within the operating range using the associated cam disc. Spindle-driven cams, which can be adjusted with a screwdriver, are available.

FEATURES

Electric actuator up to 0.6 Nm

- Drive times: 3 ... 38 sec.
- Variants: - clockwise or counter clockwise rotation
- with integrated electronic circuitry
- shaft version
- Internal position indicator
- Easily adjustable limit and auxiliary switches
- Synchronous motor

TECHNICAL DATA

SPECIFICATION

Type overview

counter clockwise rotation ¹⁾

Diagram ²⁾	Shaft ³⁾	Drive time ⁴⁾	Load torque ⁵⁾	Holding torque	Voltage ⁶⁾	Type	Remarks ⁷⁾
Nr.	Nr.	s	Nm	Nm	V		
S3	2	5	0,6	0,4	230	LKS 131-05 B 2-5 S3	
S3.1	2	5	0,6	0,4	230	LKS 131-08 B 2-5 S3.1	Without plug
S6	2	5	0,6	0,4	230	LKS 131-09 B 2-5 S6	On/off movement only
S3	2	38	0,6	0,4	230	LKS 131-12 B 2-38 S3	
S8	6	15	0,6	0,4	230	LKS 131-15 B 6-15 S8	Limit switch and potentiometer 1k
S5	6	15	0,6	0,4	230	LKS 131-16 B 6-15 S5	
S20-2	6	38	0,6	0,4	230	LKS 131-17 B 6-38 S20-2	With special 8 mm shaft
S3	6	5	0,6	0,4	230	LKS 131-18 B 6-5 S3	With special 8 mm shaft

Legend

- 1) when viewing from direction A (see dimensional drawing)
- 2) see "Circuit diagrams"
- 3) see "Dimensional drawing"
- 4) at 50 Hz for 90°
at 60 Hz, Drive times are about 20 % shorter
- 5) under nominal conditions
under extreme conditions (e.g. +60 °C, 230V -15%) the torques will be 25% lower
- 6) +10% -15%; 50...60Hz
at -15%; torque reduced by approx. 20% at undervoltage
- 7) Standard: Lever-operated cam

Technical Data

Housing

- impact-proof, heat-resistant synthetic material
Colour: black

Drive motor

- reversible synchronous motor

Switch point setting

- via stepless cam setting, spindle-driven cam with superimposed scale

Position indicator

- via co-rotating scale (under the cover)

Connection system

- fixed cable connection with 9-pin plug

Gearing

- spur gearing, maintenance-free

Output shaft

- standard plastic, interior square 8 mm

Fitting and fastening

- Fastened from inside via tapped M 5 through-holes

PCBs

- for all electrical functions, increased conductor thickness

Mains voltage

- 230 V -15% +10% or
110 V -15% +10%

Mains frequency

- 50 Hz or 60 Hz

Safety class

- II VDE 0631

Power consumption

- approx. 9 VA

Duty cycle

- 50% in 2 minutes

Interference suppression

- N (according to VDE 0785)

Actuating angle

- max. 90°

Mounting position

- any

Protection

- IP40, with appropriate design of the cable entries and screw fastening (DIN 40050)

Cable connection

- via 9-pin AMP socket connector

Direction of rotation

- see "Type overview"

Torque and holding torque

- see "Type overview"

Drive times

- 5, 15, 38 sec. for 90°

Limit and auxiliary switches

- max. 7
operation with adjustable cam discs, cams coloured in normal way:
 - blue fully closed position
 - orange low load
 - red high load
 - black spare switches for additional functions
- switching voltage
AC 24...230 V
- switching capacity
with inductive loads 250 VA

Ambient temperature

- operation 0 ... +60° C
- transport and storage -20 ... +60° C

Condensation, icing and exposure to water not permitted

Weight

- approx. 500 g

DIMENSIONAL DRAWING

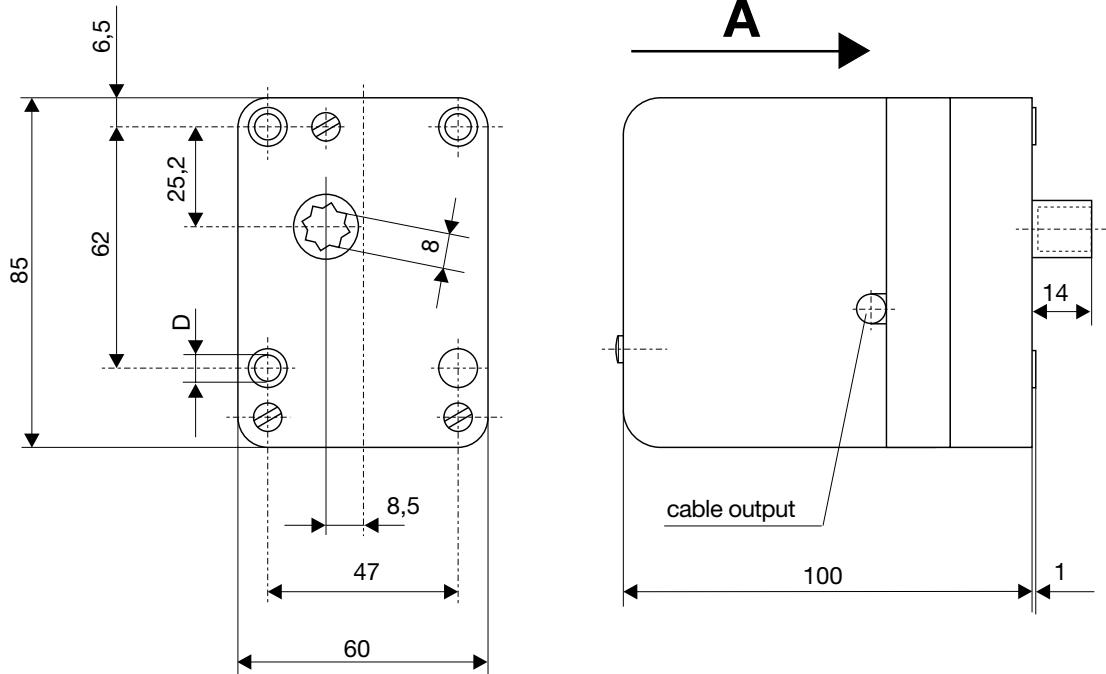

D) Fixing hole
through-hole 5,3 mm inside dia

INSTALLATION AND OPERATION

INSTALLATION AND FINAL CHECKOUT

- The regulations and standards applicable in each particular case must be observed.
- Installation and commissioning must only be carried out by qualified technicians.
- Electrical wiring must comply with national and local regulations.
- Always lay the burner ignition cable separately and as remotely as possible from the device and other cables.
- Carefully check all cabling and wiring prior to commissioning.
- Disconnect the actuators completely from the power supply when working close to terminals and connections.
- Screw the housing cover securely in place to provide shock-hazard protection on the actuator and all electrical connections.
- Electromagnetic emissions must be checked on a case by case basis.

CIRCUIT DIAGRAMS

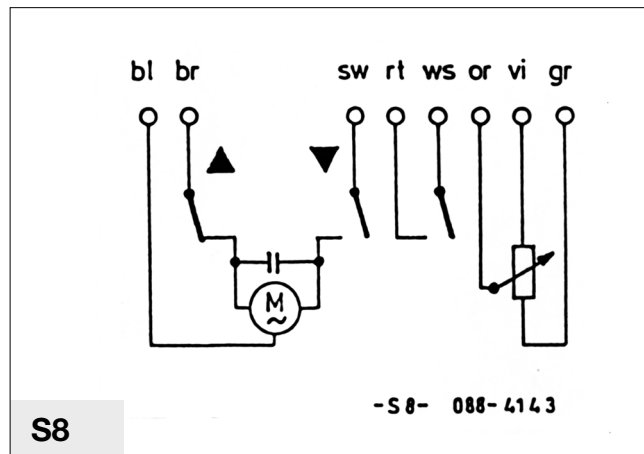
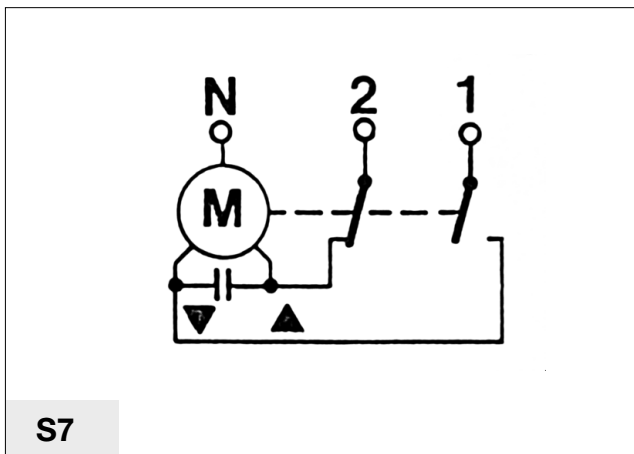
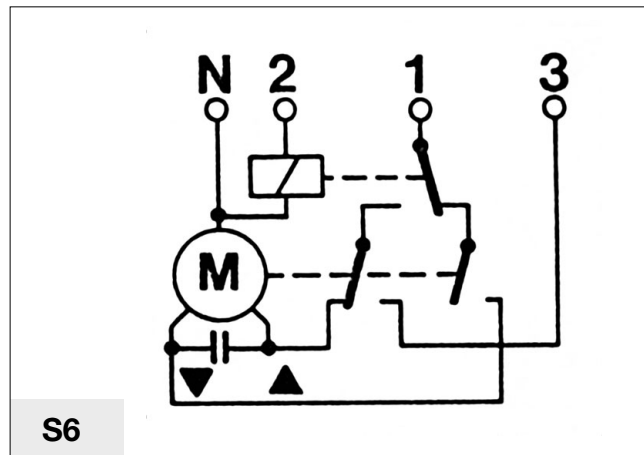
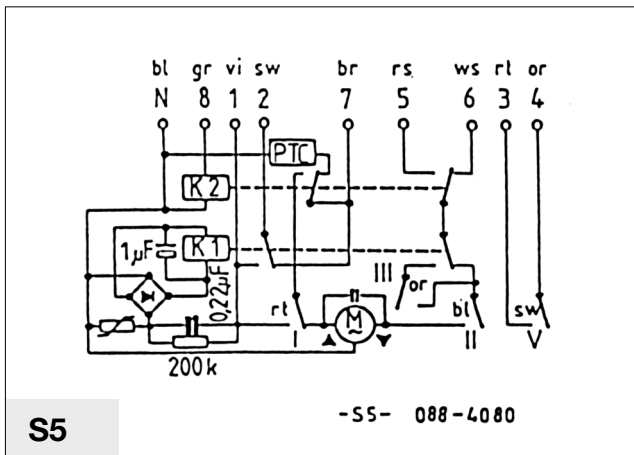
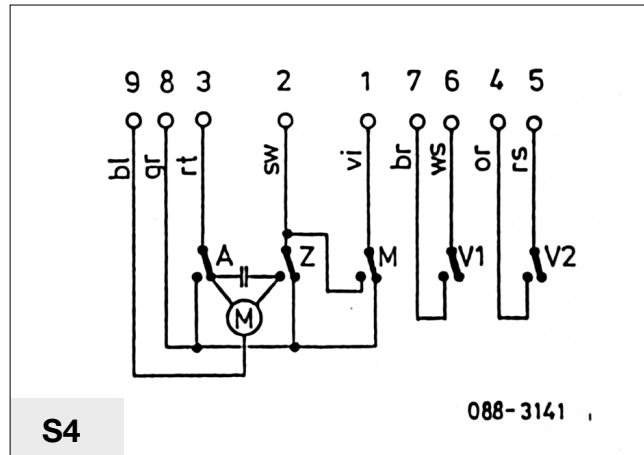
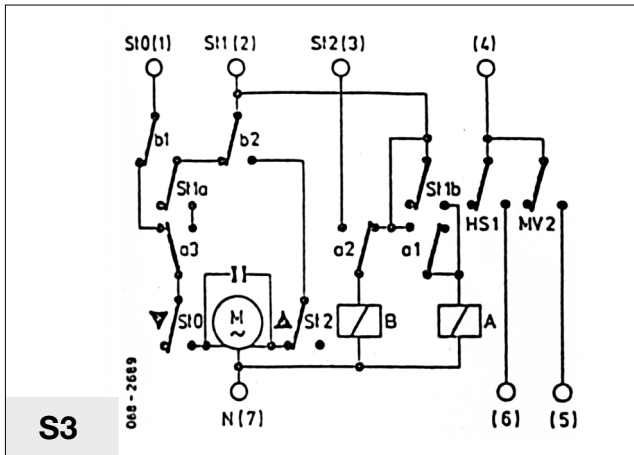

VARIOUS

STANDARDS AND APPROVALS

Conformity

- In accordance with EU Directives 73/23/EU and 93/68/EU. Conforms to EN 60730 – 1 : 1991 A1 and A11 : 1991 EN 60730 – 2 – 5 : 1991

ORDERING INFORMATION

Not for creation of new type

LKS 131-09 B 2 - 38 S3

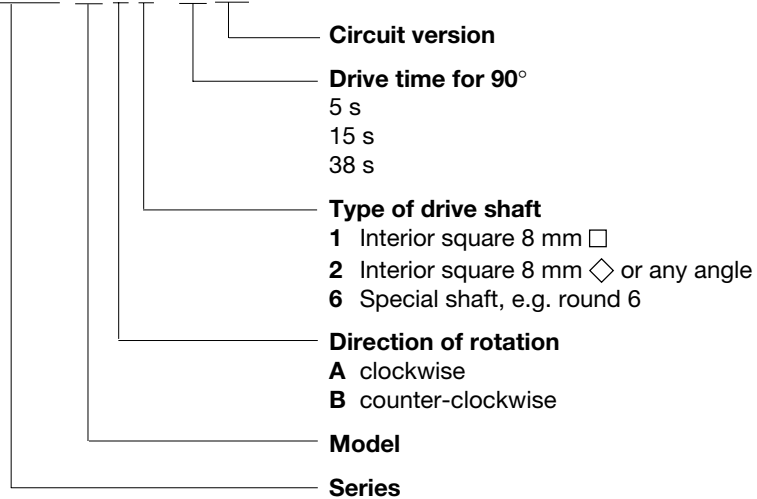

ACCESSORIES

Special versions with potentiometer on request

Honeywell

Honeywell Burner & Boiler Control Europe

Satronic AG

Honeywell-Platz 1

CH-8157 Dielsdorf

Switzerland

Phone +41 1 855 22 11

Fax +41 1 855 22 22

ACTUATOR

LKS 118

FOR AIR DAMPERS ON OIL AND GAS BURNERS

PRODUCT HANDBOOK



APPLICATION

The LKS 118 air damper actuator is designed to be fitted to oil and gas burners for simple 2 position actuation.

CONTENTS

GENERAL	
Description	2
Features	2
TECHNICAL DATA	
Specification	3
Dimensional drawings	5
INSTALLATION AND OPERATION	
Installation and final checkout	6
Circuit diagrams	6
VARIOUS	
Standards and approvals	7
Ordering information	7
Accessories	7

GENERAL

DESCRIPTION

A synchronous motor powers a output shaft via gear reducer.

An optional micro-switch is available for position indication. The opening angle can be easily and steplessly adjusted via two limit switches.

FEATURES

Electric actuator up to 0.6 Nm

- **Drive time: 5 sec.**
- **for simple damper movements on small burners**
- **Variants:** - clockwise or counter clockwise rotation
 - with optional micro-switch
 - shaft version
- **Easily adjustable limit switches**
- **Synchronous motor**

TECHNICAL DATA

SPECIFICATION

Type overview

clockwise rotation ¹⁾

Diagram ²⁾	Shaft ³⁾	Drive time ⁴⁾	Load torque ⁵⁾	Holding torque	Voltage ⁶⁾	Type	Remarks
Nr.	Nr.	s	Nm	Nm	V		
S5	3	5	0,6	0,4	230	LKS 118-05 A 3-5 S5	With feedback
S6	3	5	0,6	0,4	230	LKS 118-06 A 3-5 S6	

Counter-clockwise rotation ¹⁾

Diagram ²⁾	Shaft ³⁾	Drive time ⁴⁾	Load torque ⁵⁾	Holding torque	Voltage ⁶⁾	Type	Remarks
Nr.	Nr.	s	Nm	Nm	V		
S3	3	5	0,6	0,4	230	LKS 118-03 B 3-5 S3	
S4	3	5	0,6	0,4	230	LKS 118-04 B 3-5 S4	With feedback

Legend

- 1) when viewing from direction A (see dimensional drawing)
- 2) see "Circuit diagrams"
- 3) see "Dimensional drawing"
- 4) at 50 Hz for 90°
at 60 Hz, Drive times are about 20 % shorter
- 5) under nominal conditions
under extreme conditions (e.g. +60 °C, 230V -15%) the torques will be 25% lower
- 6) +10% -15%; 50...60Hz
at -15%; torque reduced by approx. 20% at undervoltage

Technical Data

Housing

- impact-proof plastic
Colour: black

Drive motor

- reversible synchronous motor

Switch point setting

- via steplessly adjustable limit switch

Position indicator

- none

Connection system

- fixed 3 or 4 core cable connection, cable length approx.
50 cm

Gearing

- spur gearing, maintenance-free

Output shaft

- standard: Couples to 6 mm round shaft bevelled to 5 mm.
The output shaft position can easily be corrected by
turning a gear wheel by hand

Fitting and fastening

- Fixing from outside using 2 M4 screws

Mains voltage

- 230 V -15% +10%

Mains frequency

- 50 Hz or 60 Hz

Safety class

- II VDE 0631

Power consumption

- approx. 9 VA

Duty cycle

- 50% in 2 minutes

Interference suppression

- N (according to VDE 0785)

Actuating angle

- max. 130°

Mounting position

- any

Protection

- IP 00 (DIN 40050)

Cable connection

- fixed, 3 or 4 core

Direction of rotation

- see "Type overview"

Torque and holding torque

- see "Type overview"

Drive times

- 5 sec for 90°

Switch

- 2 limit switches
operation with adjustable stops
- switching voltage
AC 24...230 V
- switching capacity
with inductive loads 250 VA

Ambient temperature

- operation 0 ... +60° C
- transport and storage -20 ... +60° C

Condensation, icing and exposure to water not permitted**Weight**

- approx. 350 g

DIMENSIONAL DRAWING

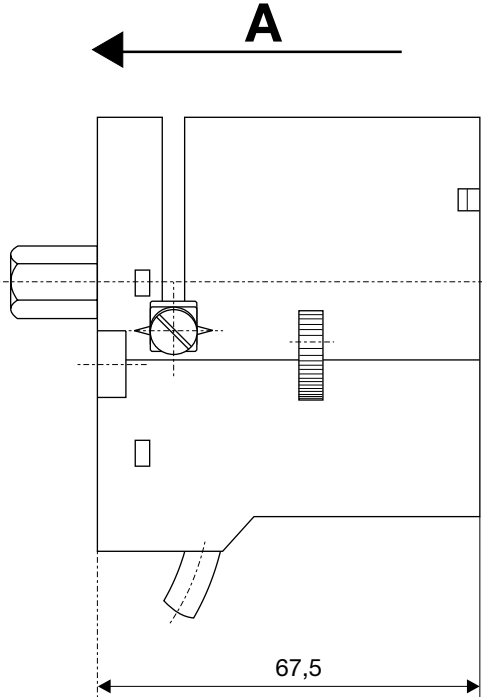
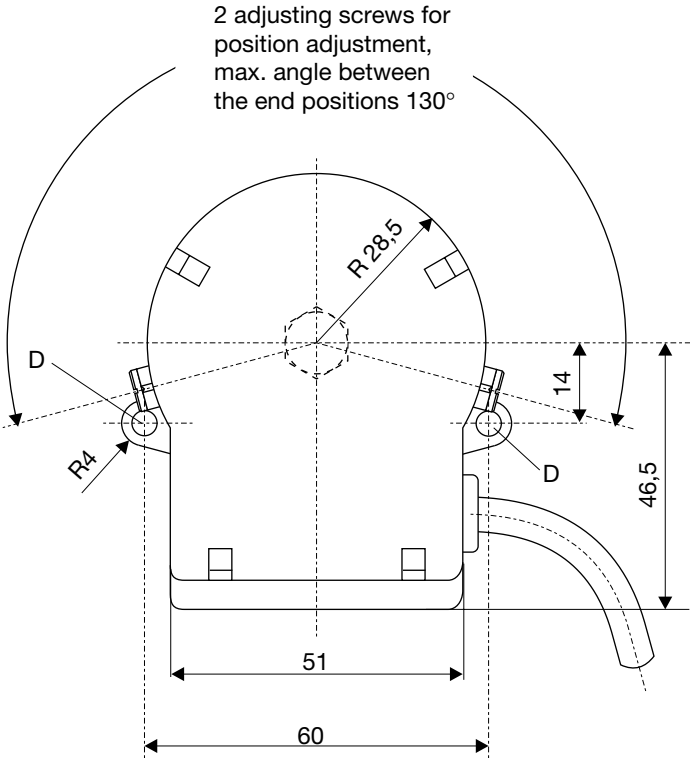

Shaft Version	Nr.
	⑥
	③

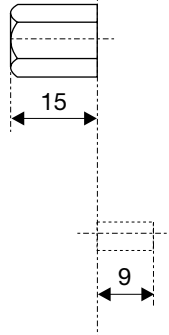

D) Fixing holes through-hole 4,4 mm inside dia

INSTALLATION AND OPERATION

INSTALLATION AND FINAL CHECKOUT

- The regulations and standards applicable in each particular case must be observed.
- Installation and commissioning must only be carried out by qualified technicians.
- Electrical wiring must comply with national and local regulations.
- Always lay the burner ignition cable separately and as remotely as possible from the device and other cables.
- Carefully check all cabling and wiring prior to commissioning.
- Disconnect the actuators completely from the power supply when working close to terminals and connections.
- Electromagnetic emissions must be checked on a case by case basis.

CIRCUIT DIAGRAMS

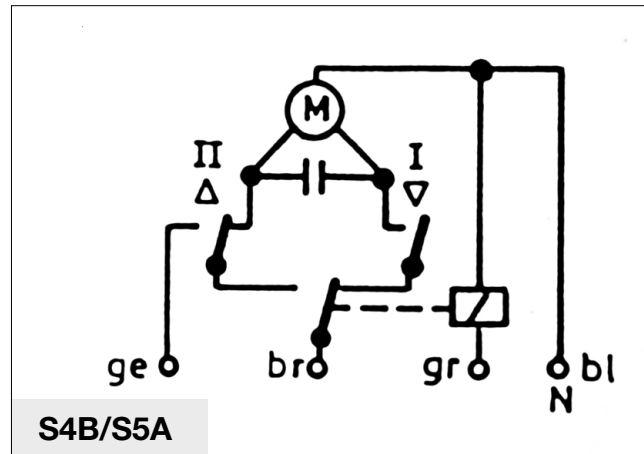
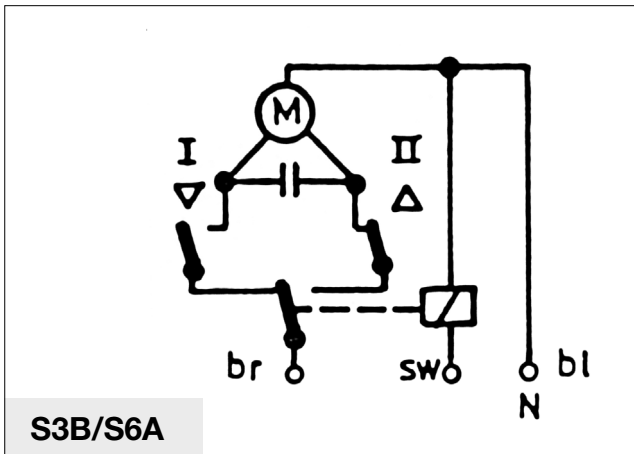

VARIOUS

STANDARDS AND APPROVALS

Conformity

- In accordance with EU Directives 73/23/EU and 93/68/EU. Conforms to EN 60730 – 1 : 1991 A1 and A11 : 1991 EN 60730 – 2 – 5 : 1991

ORDERING INFORMATION

Not for creation of new type

LKS 118-01 B 3 - 05 S3

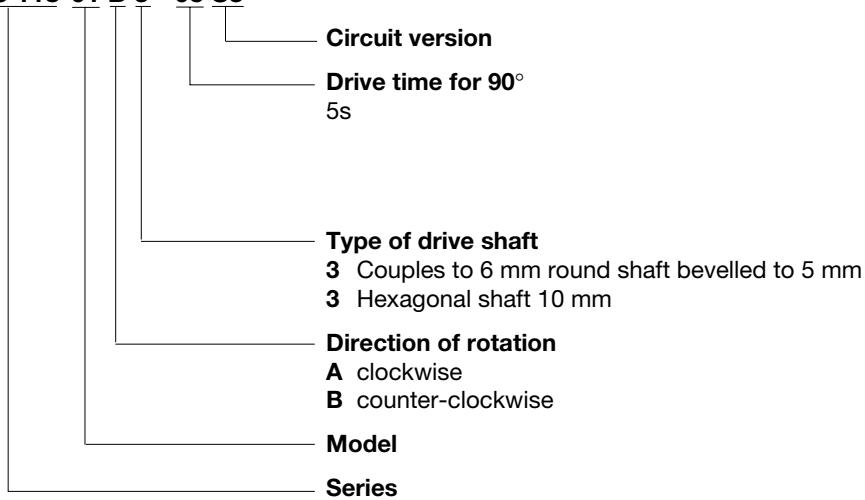

ACCESSORIES

no accessories

Honeywell

Honeywell Burner & Boiler Control Europe

Satronic AG

Honeywell-Platz 1

CH-8157 Dielsdorf

Switzerland

Phone +41 1 855 22 11

Fax +41 1 855 22 22

ACTUATOR

LKS 310

FOR AIR DAMPERS ON MULTI-STAGE AND
MODULATING BURNERS

PRODUCT HANDBOOK



APPLICATION

The LKS 310 air damper actuator is designed to be fitted to multi-stage or modulating oil and gas burners with fully closed position.

CONTENTS

GENERAL

Description	2
Features	2

TECHNICAL DATA

Specification	3
Dimensional drawings	5

INSTALLATION AND OPERATION

Installation and final checkout	5
Circuit diagrams	6

VARIOUS

Standards and approvals	8
Ordering information	8
Accessories	8

GENERAL

DESCRIPTION

A synchronous motor powers an output shaft and a backlash-free cam shaft via a gear reducer.

The cam shaft operates limit and auxiliary switches. The position at which one of the limit or auxiliary switches operates

can be adjusted steplessly within the operating range using the associated cam disc. Manually adjustable lever-operated cams or spindle-driven cams, which can be adjusted with a screwdriver, are available.

FEATURES

Electric actuator up to 15 Nm

- **Drive times: 3.5 ... 30 sec.**
- **Variants:** - clockwise or counter clockwise rotation
- with integrated electronic circuitry
- shaft version
- **Gearing can be decoupled**
- **Position indicator**
- **Easily adjustable limit and auxiliary switches**
- **Synchronous motor**
- **Particular stable design in aluminium housing**

TECHNICAL DATA

SPECIFICATION

Type overview

Clockwise rotation ¹⁾

Diagram 2)	Shaft 3)	Drive time 4)	Load torque 5)	Holding torque	Voltage 6)	Type	Remarks 7)
Nr.	Nr.	s	Nm	Nm	V		
S7	5	30	15	10	230	LKS 310-09 A 5-30 S7	
S7.1	5	15	15	10	230	LKS 310-13 A 5-15 S7.1	
S1	5	30	15	10	230	LKS 310-15 A 5-30 S1	
S1.1	5	15	15	10	230	LKS 310-19 A 5-15 S1.1	Spindle-driven cam
S12	5	30	15	10	230	LKS 310-21 A 5-30 S12	Spindle-driven cam
S7.1	5	10	10	10	230	LKS 310-24 A 5-10 S7.1	
S7.1	5	15	15	10	230	LKS 310-25 A 5-10 S7.1	
S6	6	15	15	10	230	LKS 310-29 A 6-15 S6	
S12	5	7	7	7	230	LKS 310-33 A 5-7 S12	Spindle-driven cam

Counter-clockwise rotation ¹⁾

Diagram 2)	Shaft 3)	Drive time 4)	Load torque 5)	Holding torque	Voltage moment	Type	Remarks 7)
Nr.	Nr.	s	Nm	Nm	V		
S11	5	7	7	7	230	LKS 310-16 B 5-7 S11	
S7.1	5	7	7	7	230	LKS 310-17 B 5-7 S7.1	
S1.1	5	15	15	10	230	LKS 310-20 B 5-15 S1.1	Spindle-driven cam
S7.1	5	10	10	10	230	LKS 310-23 B 5-10 S7.1	
S1.2	5	13	13	10	110	LKS 310-30 B 5-13 S1.2	Spindle-driven cam (60 Hz)
S7.1	5	15	15	10	230	LKS 310-31 B 5-15 S7.1	
S7.1	5	10	10	10	230	LKS 310-32 B 5-10 S7.1	

Legend

- 1) when viewing from direction A (see dimensional drawing)
- 2) see "Circuit diagrams"
- 3) see "Dimensional drawing"
- 4) at 50 Hz for 90°
at 60 Hz, Drive times are about 20 % shorter
- 5) under nominal conditions
under extreme conditions (e.g. +60 °C, 230V -15%) the torques will be 25% lower
- 6) +10% -15%; 50...60Hz
at -15%; torque reduced by approx. 20% at undervoltage
- 7) Standard: Lever-operated cam

Technical data

Housing

- robust aluminium housing with plastic cover

Drive motor

- reversible synchronous motor

Clutch

- red lever, separates gearing from motor

Switch point setting

- stepless cam setting, lever-operated or spindle-driven cams; if spindle-driven, with superimposed scale

Position indicator

- if desired the cover can contain a window and pointer, internally via a co-running pointer and scale

Connection system

- terminal blocks

Gearing

- spur gearing, maintenance-free

Drive shaft

- steel

Fitting and fastening

- front of gear acts as contact area. Fixing from outside via M5 or M6 screws, thread in housing

PCBs

- for all electrical functions, increased conductor thickness

Mains voltage

- 230 V -15% +10%

Mains frequency

- 50 Hz or 60 Hz

Safety class

- I VDE 0631

Power consumption

- 7...15 VA

Duty cycle

- Depending on motor, 50 to 70 % in 2 minutes

Interference suppression

- N (according to VDE 0785)

Actuating angle

- 90°, in exceptional cases also larger

Mounting position

- any

Protection

- IP54, with appropriate design of the cable entries, cover without window (DIN 40050)

Cable entries

- 2 x PG11

Cable connection

- terminal block for 0.5 mm² (min.) and 2.5 mm² (max.)

wire cross-section

Direction of rotation

- see "Type overview"

Torque and holding torque

- see "Type overview"

Drive times

- 3.5 ... 30 sec for 90°

Limit and auxiliary switches

- max. 7
operation with adjustable cam discs, cams coloured in normal way:
 - blue fully closed position
 - orange low load
 - red high load
 - black spare switches for additional functions
- switching voltage
AC 24...230 V
- switching capacity
with inductive loads 250 VA

Ambient temperature

- operation 0 ... +60° C
- transport and storage -20 ... +60° C

Condensation, icing and exposure to water not permitted**Weight**

- approx. 1.8 kg

DIMENSIONAL DRAWING

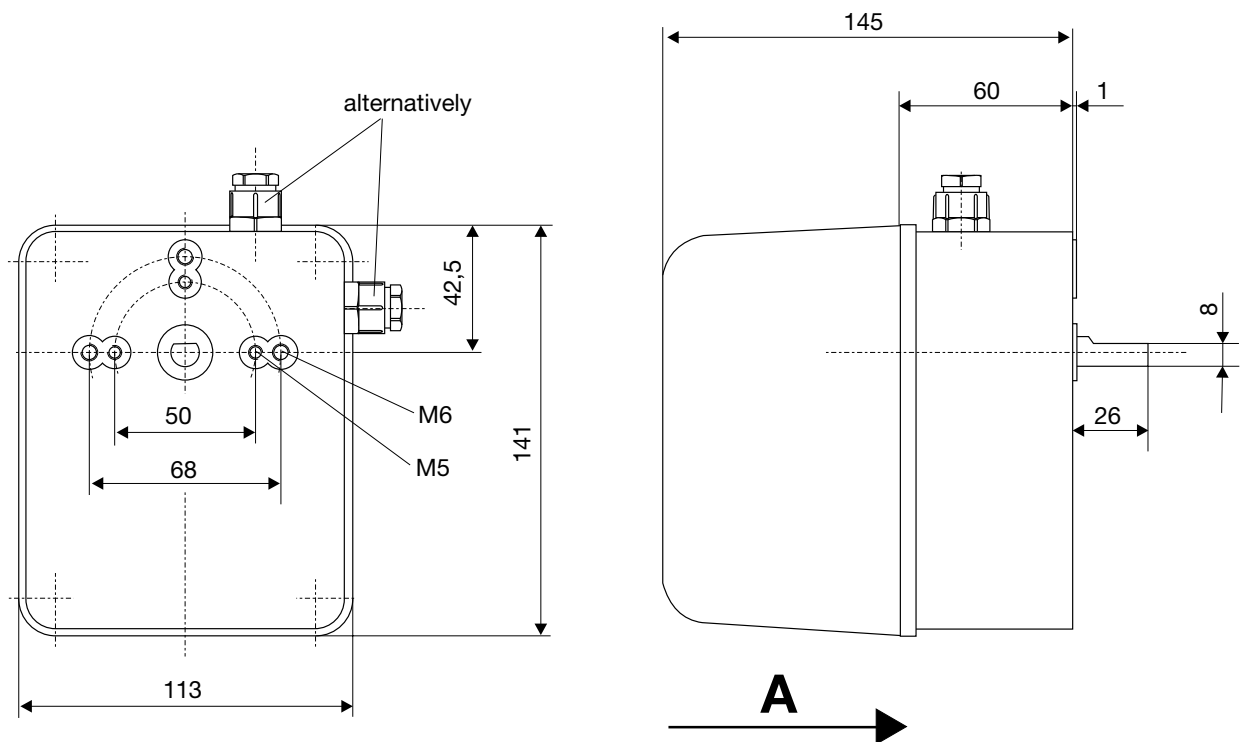

INSTALLATION AND OPERATION

INSTALLATION AND FINAL CHECKOUT

- The regulations and standards applicable in each particular case must be observed.
- Installation and commissioning must only be carried out by qualified technicians.
- Electrical wiring must comply with national and local regulations.
- Always lay the burner ignition cable separately and as remotely as possible from the device and other cables.
- Carefully check all cabling and wiring prior to commissioning.
- Disconnect the actuators completely from the power supply when working close to terminals and connections.
- Screw the housing cover securely in place to provide shock-hazard protection on the actuator and all electrical connections.
- Electromagnetic emissions must be checked on a case by case basis.

CIRCUIT DIAGRAMS

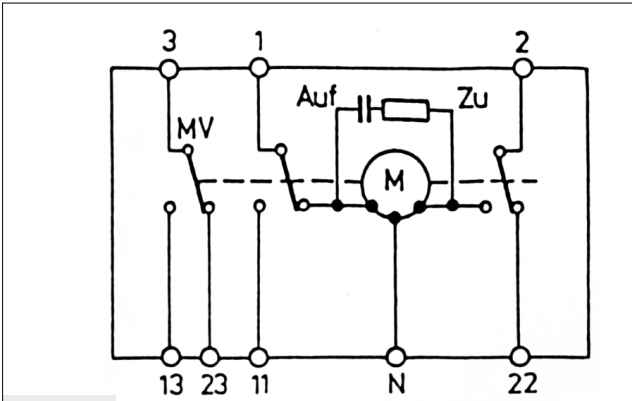

S1

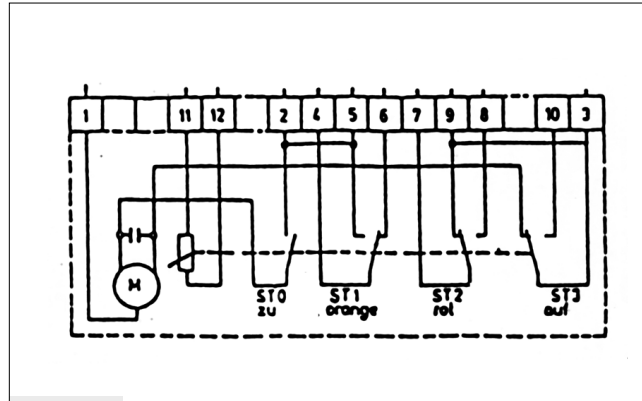

S2

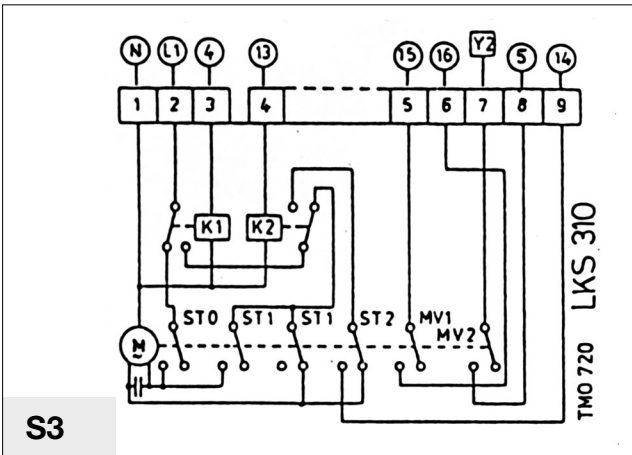

S3

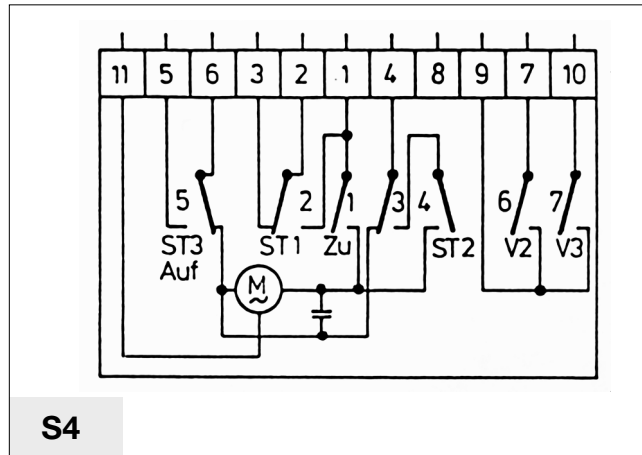

S4

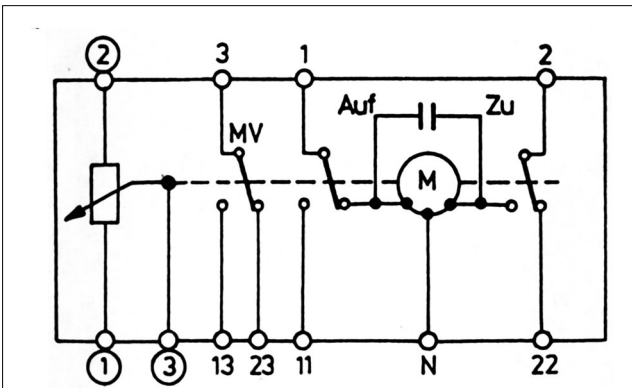

S5

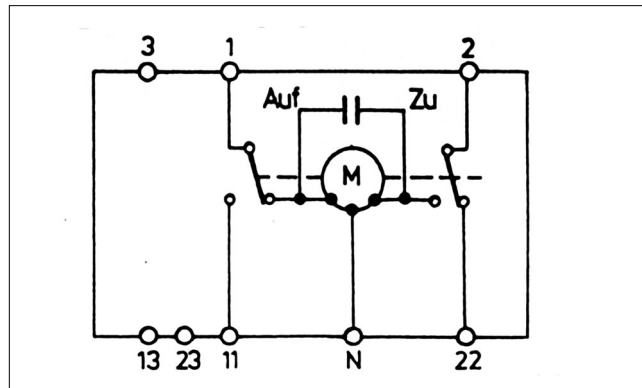

S6

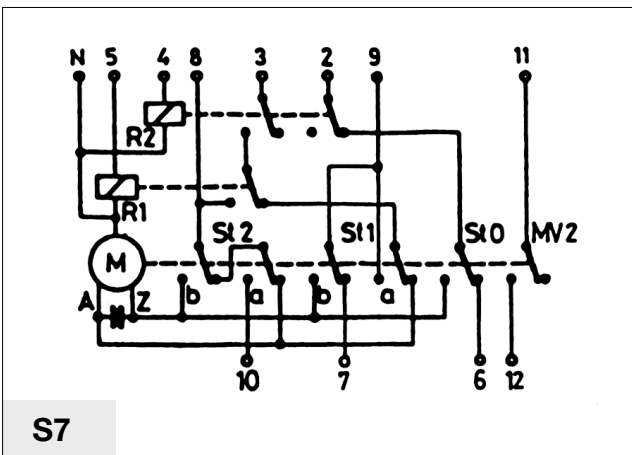

S7

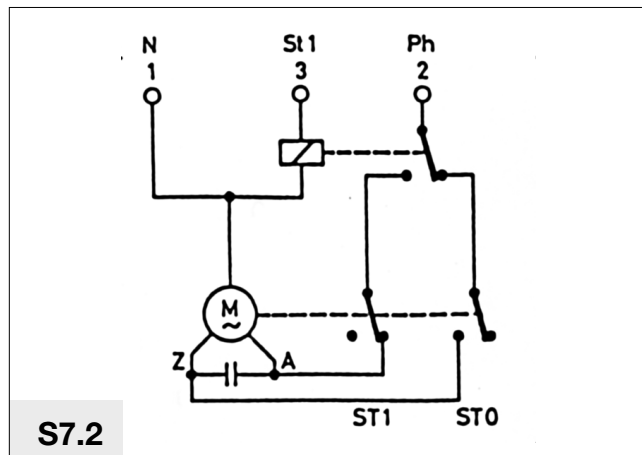

S7.2

CIRCUIT DIAGRAMS

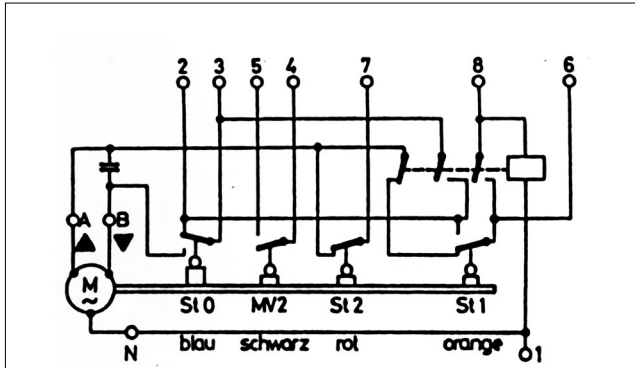

S8

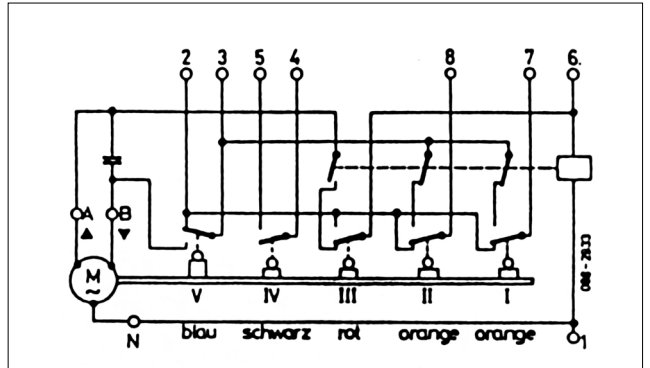

S9

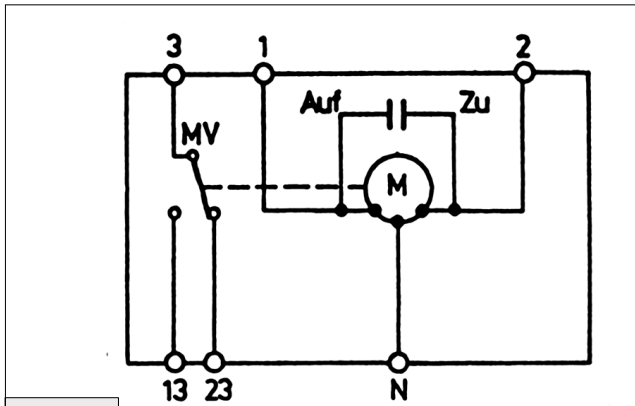

S10

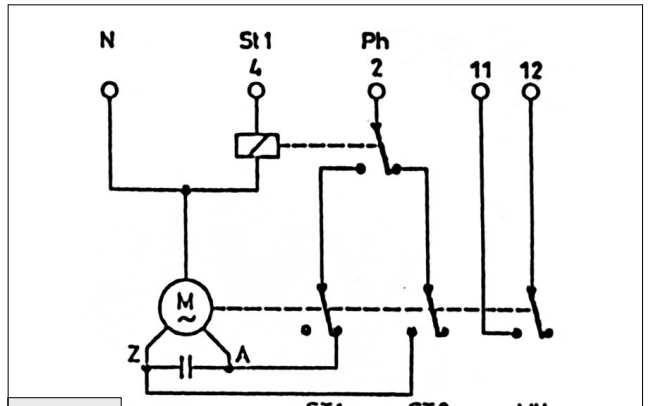

S11

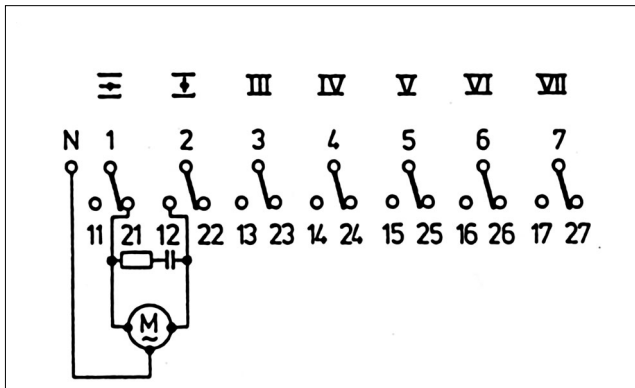

S12

VARIOUS

STANDARDS AND APPROVALS

Conformity

- In accordance with EU Directives 73/23/EU and 93/68/EU. Conforms to
EN 60730 – 1 : 1991 A1 and A11 : 1991
EN 60730 – 2 – 5 : 1991

ORDERING INFORMATION

Not for creation of new type

LKS 310-15 B 5 - 30 S1

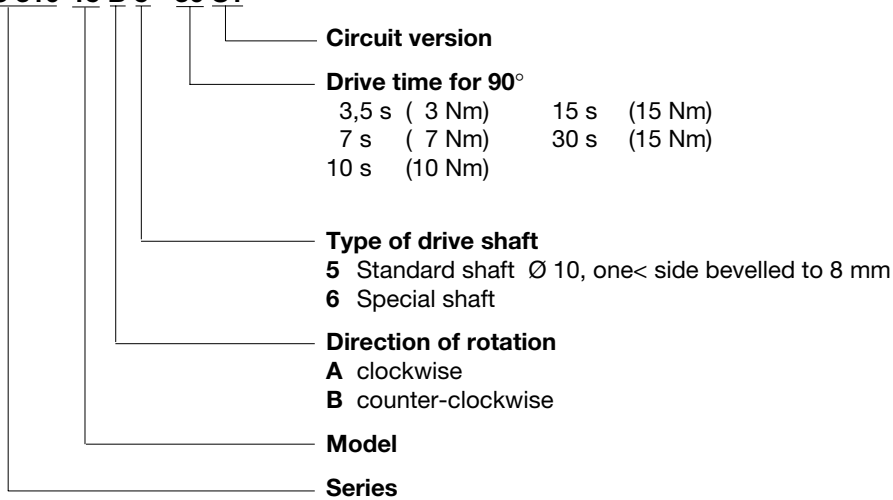

ACCESSORIES

Potentiometer-retrofit sets only on request

Honeywell