

Internal Gear Pump Series PON



Table of Contents

1. General Safety Notes	2
1.1 Intended Use	2
2. General Information	3
2.1 Operational Limits	3
2.2 Materials Used	4
3. Installation	4
3.1 The Following must be Observed for Installation and before Commissioning	4
4. Commissioning	7
5. Operation	8
5.1 Inspection and Maintenance	8
5.2. Preservation	8
5.3 Troubleshooting.....	8
6. Environment	9
7. Characteristic Curves and Figures for PON Type hp Pumps	10

1. General Safety Notes



Indicates a potentially dangerous situation. If this is not avoided, small or light injury may result.



Indicates general information on a danger of property damage.

Indicates general information on a danger of personal injury.

The notes for installation and maintenance are intended for a specialist!

Pursuant to DIN EN 12514-1 section 4.3.3., the operator of the complete system must provide a pressure controller, e.g. a pressure control device.

The operator shall be responsible for complying with the general accident prevention, safety and operating provisions.

1.1 Intended Use

In spite of careful safety optimization being performed for the PON series pumps, there is still some residual danger from operating the pump. The safety notes explained above and in the following must be observed under any case to prevent personal injury and / or damage to the pump. By complying with the instructions at all times, you will increase your pump's service life and retain full warranty claims towards the manufacturer in the case of damage.

Any pumps are subjected to a performance test after manufacture and are equipped with a test card.

2. General Information

The PON series pumps are internal gear pumps. They have an integrated overflow valve, a filter element integrated into the pump housing and a return port. There are four different sizes covering a range of 90 to 320 l/h at a rotation speed of 2800 min⁻¹. Pressures generated can reach up to 40 bar. The delivered pump is intended for two-pipe system ex works. For switching from two- to one-pipe- system, unscrew a threaded pin (for instructions, see page 5 of these operating instructions).

The rotor's rotation opens and enlarges the chambers between pinion gear and rotor on the suction side. This opening causes an underpressure, which sucks the medium from the suction line. Each rotation of the gear pair transports medium from the suction to the pressure side. On the pressure side, the gears interlock again and press the medium from the chambers; pressure is built up and the medium is removed through the pressure line. When the teeth of pinion gear and rotor are fully interlocking again, the contact of these teeth seals the suction and pressure sides from each other. On the suction side, however, sealing is achieved by toleration between rotor, pinion gear, cover by a filling piece or the pump housing. This is necessary to avoid pressure equalization between the pressure and suction sides and to prevent a lubrication film between the different parts.

The PON series pumps are intended for transporting heating oils pursuant to DIN 51603. Where other media has to be transported, this must be verified by the manufacturer. Otherwise, the pump's service life may be decreased. For use with pre-heated media - which have a higher viscosity when cooled - the manufacturer recommends the use of an electrical standby and companion heating system H3 without thermostat (see figure 5 on page 8). It is available as an accessory.

The following information is engraved into the pump body:

- Exact description of the pump type and code for the maximum permissible speed and build.
- Manufacturing date– MM/YY
- Rotational direction arrow (corresponding to order)
- Manufacturer's pump number

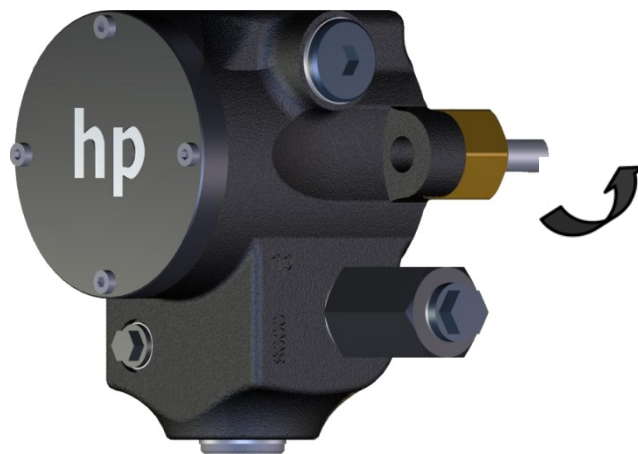

Fig. 1

2.1 Operational Limits

Capacity	90- 320 l/h
Pressure	up to 40 bar
Min. inlet pressure	- 0.2 bar
Max. inlet pressure	5.0 bar
Max. permissible rotation speed (at 50 Hz)	2800 min ⁻¹
Temperature up to	150 °C

2.2 Materials Used

Pump housing	Hydraulic casting GG25
Rotor	EGT 80
Pinion gear	16MnCr5
Cover plate	Continuous casting GG25
Lower bearing	Continuous casting GG25
Shaft sealing	Coal / SiC- Viton
Valve parts	Spring wire steel, 11SMnPb30+C, 16MnCrS5

All hp pumps are equipped with axial face seals. They are temperature-resistant up to 150°C. These axial face seals are relieved at the pump's suction side. Maximum pressure load on the GLRD, i.e. suction side, against temperature (see adjacent figure).

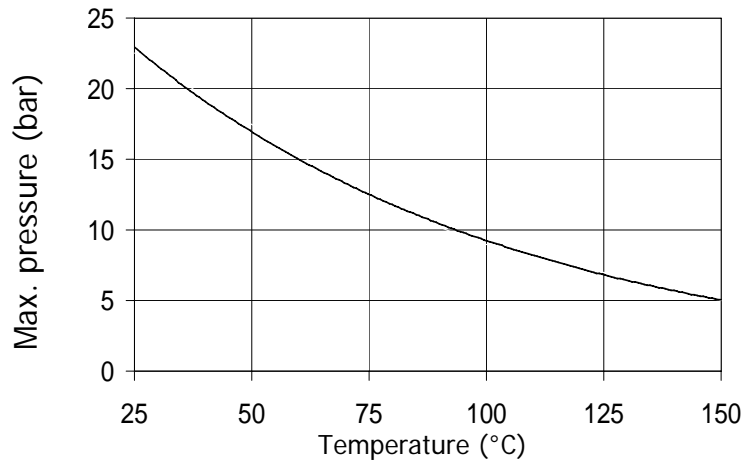

Item No.: 0190015

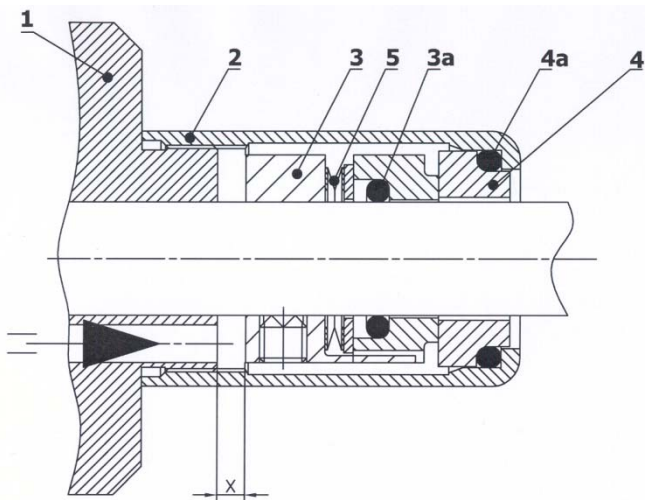

1. Pump housing
 2. Union nut
 - 3a. O-Ring
 3. Tappet
 - 4a. O-Ring
 4. Counter ring
 5. Spring
- X Installation size

Fig. 2

3. Installation

3.1 The Following must be Observed for Installation and before Commissioning

- The rotational direction must be correct (see engraved arrow).
- The pump pressure must be pre-set when the magnetic valves are closed.
- Installation must be performed so that the pump shaft and drive shaft are perfectly aligned in axial direction and so that there is no radial pressure. Furthermore, a coupling appropriate for the pump shaft in size and weight and not transferring any imbalances to the pump must be used.
- The axial play between the coupling halves should be 1 to 1.5 mm. Rotation coupling parts must not touch any fixed pump or engine parts axially!

- All connections and lines must be installed free of tension and tight. We recommend only using sealing rings made of copper, aluminum or plastics. Never use hemp or similar materials.
- In two-pipe-system, the return flow line must be led back to the tank and must never be closed off. Otherwise, the pump's overpressure protection will no longer work.
- The pipes must be cleaned from any dirt and metal particles before the pump is connected.
- The suction connection (see figure 3) of the pump is filled with oil. Then the suction line is connected to thread connection "A".
- The nozzle line is connected to nozzle opening "R" or "L", depending on the casing build. (Fig.3)
- Remove the screw plug for connecting the manometer (Fig.4). For this, observe a suitable manometer pressure range (according to the pump's pressure range).
- Before switching on the pump, check that all locking valves in the pipes and at the tank are open and that there is enough oil in the tank.
- Ensure that the pump is operated in the intended rotational direction (engraved arrow). Connect the motor according to the information on the type plate and switch it on. Preventively provide a motor protection switch with overload function!
- The pump has a bypass plug ex works and is thus defined for two-pipe-system (Fig.3). A return flow connection to the tank is required for two-pipe-system.
- The bypass plug for switching from one to two-pipe-system is a threaded pin with a hexagon socket (size: 2mm). For one-pipe-system, the bypass plug is removed by unscrewing the threaded pin and the return flow connection is closed off tightly with a sealing ring and plug.
- Either of the two suction connections can be selected for the suction side (Fig.3). Where required, a manometer can be connected to the second suction connection to measure the suction pressure. Otherwise, the unused suction connection is closed off with a sealing ring and plug screw.
- Before connecting the pressure line, the plastics cap on the nozzle ejection side must be removed.
- For pressure regulation, the plug screw (see figure 4) must be removed.

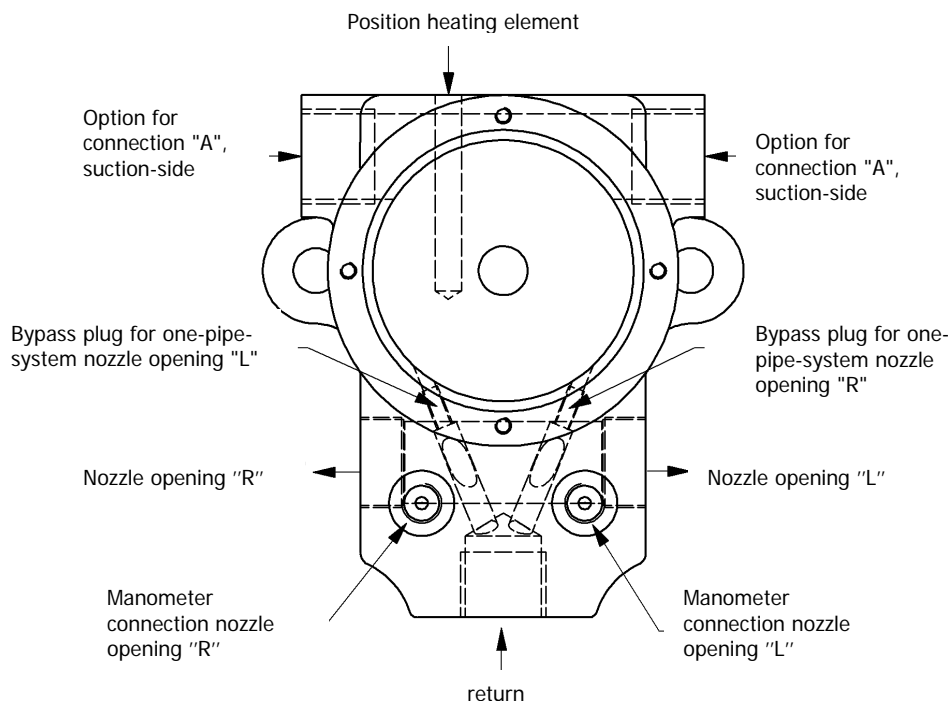

Fig. 3

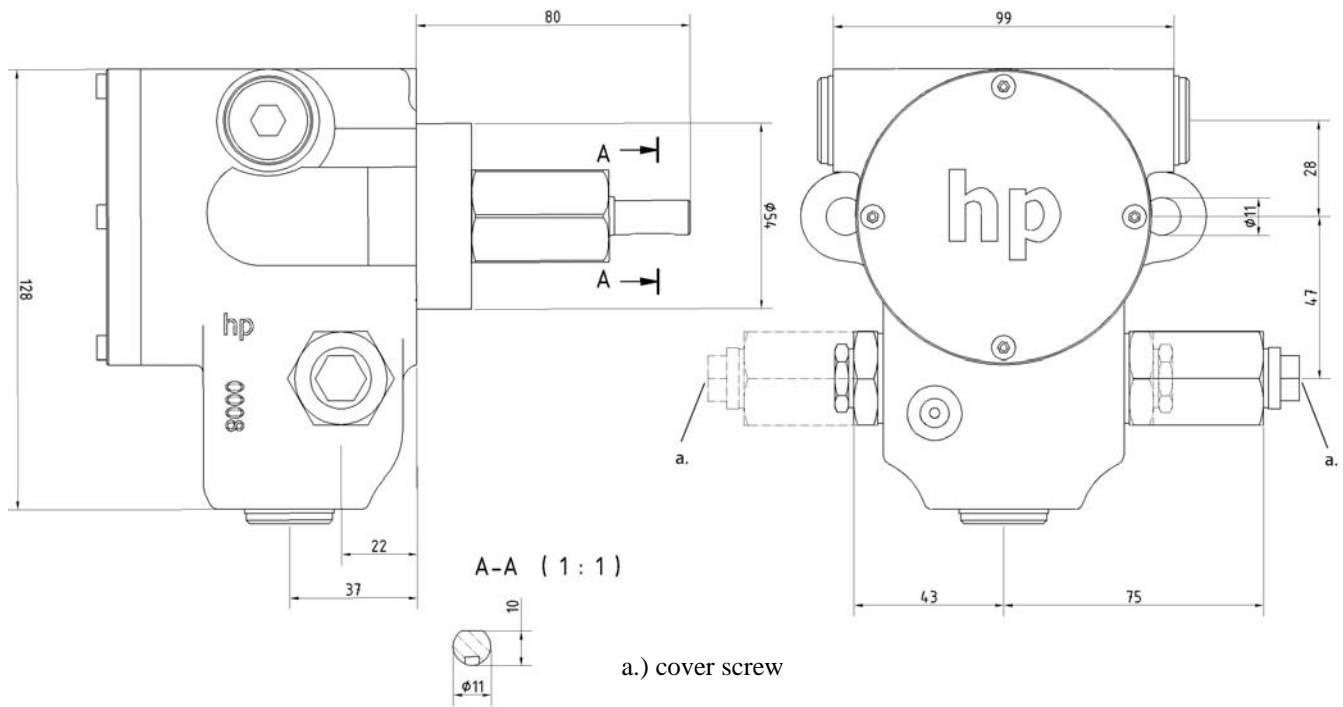

Fig. 4

- After removing the cover screw, the pressure regulating screw with hexagon socket (6mm size) is visible. Use a hexagon wrench to:
 - **turn it to the right to increase pressure**
 - **turn it to the left to decrease pressure**
- When adjusting the desired operational pressure, observe that it may only be set within the permissible pressure range of the included pressure spring (pressure level 1 to 4).

Pressure level	Pressure range	Factory settings
1:	from 1 - 4 bar	2 bar
2:	from 2 - 9 bar	6 bar
3:	from 6 - 25 bar	15 bar
4:	from 15 - 40 bar	15 bar

Attention! Setting an operational pressure exceeding the pressure range will cause the spring to lock and lead to pressure surges and thus to pump outage after a short time.

- Then the pressure is set, the pressure adjustment cover screw and its sealing must be replaced oil-tight.
- The pump shaft is sealed to the outside with a mechanical seal made of the materials coal / SiC and Viton elastomer.
- The free shaft end has a diameter of 11 mm and is equipped with a groove and spring pursuant to DIN 6885-A-4x4x14.

NOTICE

Non-compliance with the max. pressure range may cause spring blockage. These in turn causes pressure surges and thus pump outage after a short time.

If the medium rotates within the pump for too long, this may cause damage to the valve, overheating and, as a result, mechanical damage.

For highly viscous media, a pump heating is prerequisite. To avoid cavitations and damage to the shaft sealings, the heating times must be observed under any circumstances.

Because of heat expansion, all valves must be open when heating.

Pumps must never be used as a fixating point for the connected pipes. Any forces and moments appearing, e.g.

- Tensions
- Expansion of pipe lines due to temperature influence or reaction forces must be avoided.
- To prevent possible heat expansion of pipe lines, we recommend installing compensators.
- The suction line must be designed so that the flow speed is between 0.5 und max. 1.0 m/sec.
- The pressure line must only reach a maximum of 2 – 2.5 m/sec.
- The suction line must be vacuum-tight and placed in a rising fashion.
- Ensure that the pump and pipe system is not contaminated, e.g. by purging.
- When testing the pipe system for tightness, the max. permissible shaft sealing supply pressure must not be exceeded.

NOTICE

Never use water as purging liquid!
Danger of corrosion!

4. Commissioning

CAUTION

Ensure that the pump does not start up dry. It must be filled with oil.

Mechanically abrasive and chemically aggressive components in the medium reduce the pump service life.

Clear your pipe lines from any dirt or metal particles before connecting it to the pump.

Ensure correct rotational direction (see engraved arrow).

Only perform the basic settings or adjustment of the pump pressure when the pressure line is closed.

Before installation, ensure that the pump and drive shafts correspond exactly in axial direction. There must not be any radial pressure.

Use a coupling suitable for the pump shaft in respect of size and weight. This way, you can avoid transferring imbalances onto the pump shaft.

Accessories

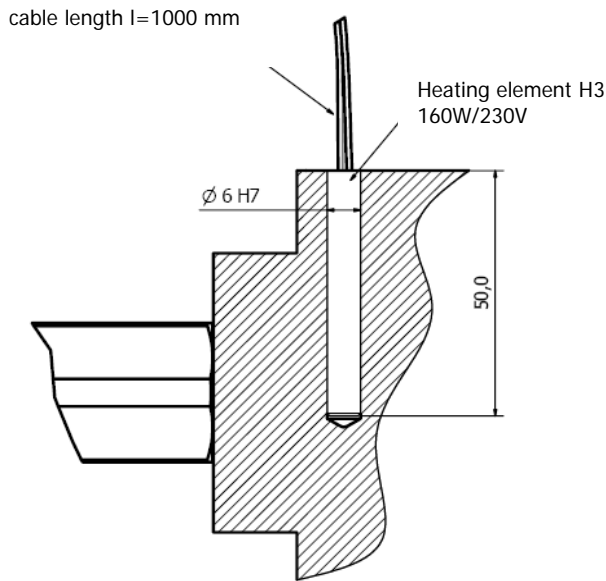

Fig. 5

hp-electrical standby and companion heater

All PON type hp pumps can be equipped with an H3 heating cartridge as electrical standby and companion heating system without thermostat.

Item number: 0190054/62

5. Operation

5.1 Inspection and Maintenance

The pump is provided with a suction filter integrated in the pump casing. The filter must be checked for dirt regularly and replaced if required. The mesh width of the filter element depends on the viscosity of the transported medium. Transported media with a high viscosity (heavy heating oil) require a filter element with a mesh width of 630 µm (**item number: 082.0941**) and transported media with a low viscosity a filter element with 160 µm respectively (**item number: 082.0940**).

To exchange the filter element, remove the cover lid. Now the filter element can be replaced. The pump supply must be within a pressure range of -0.2 to 5 bar.

NOTICE

Filter elements must be disposed of under environmental considerations.

5.2. Preservation

After the test run, testing oil remains in the pump to preserve it. The parts not treated ex works must be re-treated by the operator according to the local conditions.

If the pump is inactive for an extended period or stored, it must be preserved with acid-free non-resinous oil and stored dryly.

5.3 Troubleshooting

Errors appearing	Possible cause
The pump does not prime	1, 2, 3, 4, 5, 12
The pump does not work at full capacity	3, 4, 5, 8, 9, 10, 11, 17, 18
The pump is operating noisily	3, 4, 5, 6, 7, 10, 11, 13, 17
The motor heats up	9, 10, 13
Uneven transport	3, 5, 8, 10, 11
Shaft seal is not tight	7, 10, 14, 15, 16

No.	Possible cause	Removal
1.	No medium in the pump	Fill pump with medium
2.	Pump has the wrong rotational direction	Set rotational direction according to the engraved arrow
3.	Filter element, valve or lines are clogged	Check and clean parts
4.	Suction line or shaft seal are leaking	Check suction line, connection points and valves or shaft face seal
5.	Suction head too large	- Decrease height difference - Shorten line - Increase line diameter - Decrease medium viscosity by heating
6.	Axis error	Pump, coupling and motor: - Align shaft end precisely - Balance coupling
7.	Vibrations and pulsations in the system	- Use elastic bearings for the aggregate - Use hoses for connections
8.	The overflow valve is jammed or set too low	Check or adjust valve
9.	Wrong speed	- Check motor speed and power consumption - Compare voltage and frequency to the type plate
10.	Medium too viscous	- Increase medium temperature - Lower speed
11.	Air inclusions or gas formation in the medium	- Remove leakages - Decrease suction height - Increase feed pressure
12.	Pump does not vent	Vent pressure line at the highest point
13.	Motor bearing damaged	Renew motor bearings
14.	Shaft seal damaged	Replace shaft seal
15.	Feed pressure too high or too low	- Decrease feed pressure in the system - Insert check valve on the pressure side
16.	Cold start when transporting heavy oil	Install pump heating and observe pre-heating time
17.	Overflow valve fluttering	Set opening pressure higher by turning the setting screw clockwise.
18.	Overflow valve leaking	Clean overflow valve

NOTICE

For economic reasons, we recommend providing a reserve pump right at the burner.

6. Environment

Of course, hp-TECHNIK focuses on **Environmental protection** for its development work! To ensure that the environment does not take damage from our products - caused, e.g. by environmentally harmful media escaping unnoticed - we will even increase our efforts for the further development of our **hp- Program**.

We are continuously working to decrease effects on the environment as well as energy and resource consumption - far exceeding the measure required for compliance with environmental protection laws and regulations.

Environmentally compatible actions are not only a task for each and every employee, but must also be supported continuously by the management. We ensure that our environmental policy is effectively implemented. The technical and organizational procedures required for this are inspected regularly and continuously developed.

We support our customers in the environmentally compatible use of our products.

7. Characteristic Curves and Figures for PON Type hp Pumps

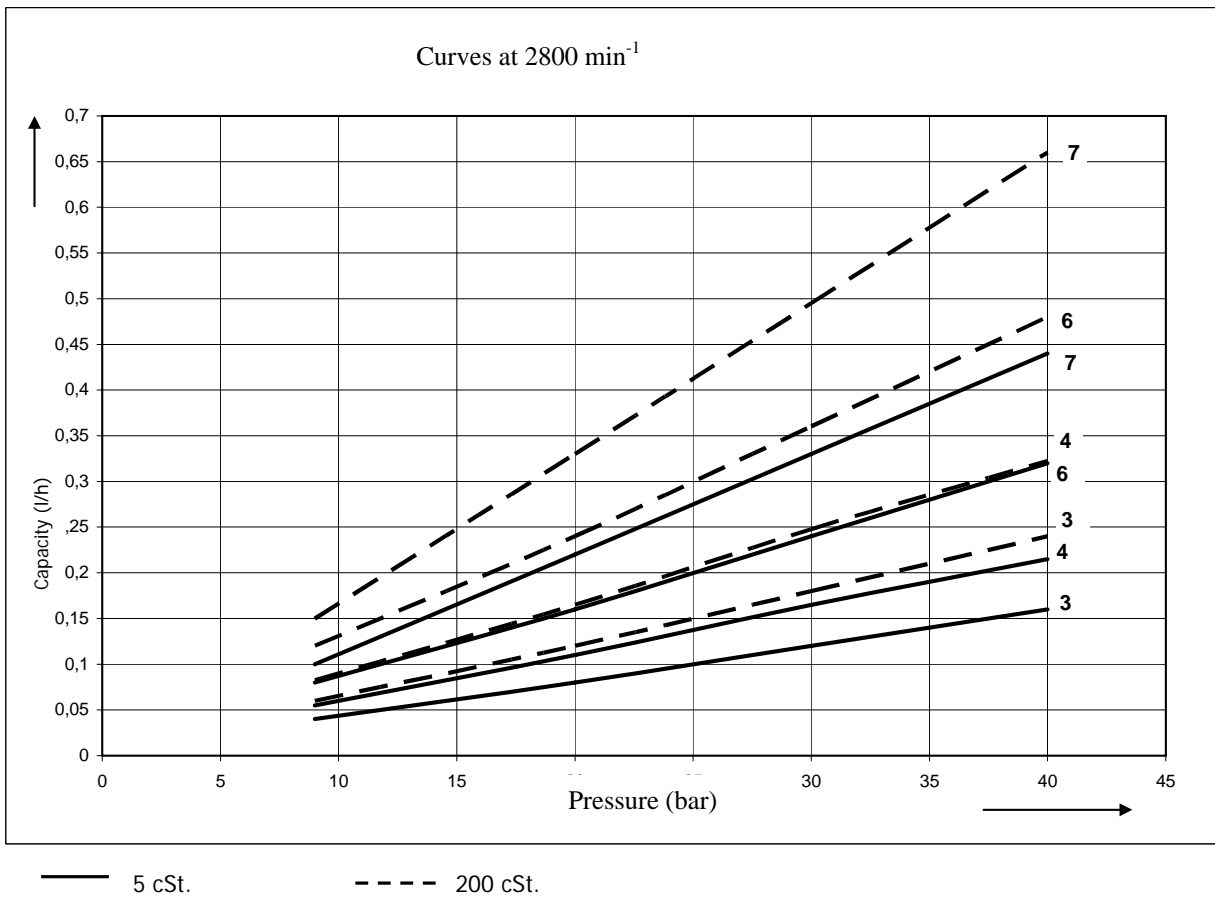
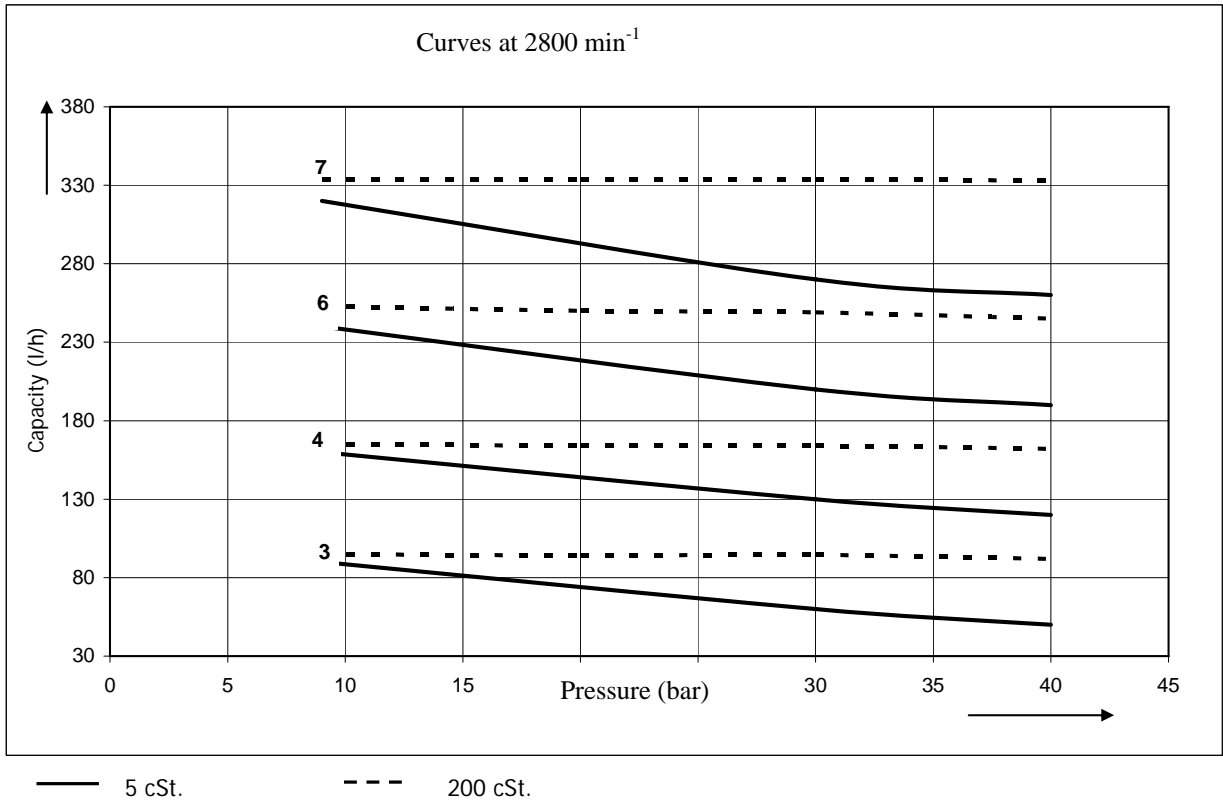

Technical Selection Chart

Direction of rotation

I = indirect – counterclockwise

D = direct – clockwise

R = on the right-hand side

L = on the left-hand side

Nozzle Port

The direction of rotation can only be changed in the factory. Therefore please assure that you state the desired direction of rotation and the direction of the nozzle port as per the size chart/ sheet when ordering! Standard design of the pump for two pipe installation, design for one pipe installation can be changed individually. (see operation installation and maintenance instructions)

hp-internal gear pump up to 40 bar

	capacity l/h at: n = 2800 min ⁻¹ viscosity 5 cSt.		direction of rotation	nozzle port	order number			max. allowed pump RPM (min ⁻¹)	gear rotor size Ø	initial pump breakaway torque	Net weight kg
	9 bar	40 bar			I-L	I-R	D-L				
PON 3	90	60	D- direct – clockwise	R	0130601	0130611	0140601	3600	25	1,2 Nm	5,0
PON 4	160	130			0130602	0130612	0140602				
PON 6	240	200	I = indirect– counter- clockwise	L	0130603	0130613	0140603	3600	25	1,2 Nm	
PON 7	320	270			260	0130604	0130614				
capacity at 9 bar in l/h		connection		pressure range			RPM (min ⁻¹)		medium		accessories
PON 3	90	nozzle 1/4" suction side 1/2" bypass 1/2"	manometer 1/8"	1=1-4			1 = 1400 min ⁻¹		0= fuel oil EL+ L MGO/MDO		H3- heating element PON
PON 4	160	1/4"	1/8"	2=2-9			2 = 2800 min ⁻¹		5= fuel oil M+S		E- one pipe installation
PON 6	240	1/4"	1/8"	3=6-25							Z- two pipe installation
PON 7	320	1/4"	1/8"	4=15-40							

example for order numbers:

