

Aggregat-Series: UHE



**Please adhere to the following points during installation and prior to initial start-up:**

1. The pump will not start up when dry. First fill it with oil.
2. Assure that all pipelines are free of dirt and soil. Suction lines must be bled via the manometer connection on the delivery side - particularly when long suction lines are being used.
3. Make sure that the pump rotates in the direction designated by the arrow.
4. Shut the solenoid valves before setting or resetting the pump pressure.
5. When installing the pump, make sure that you align the pump shaft and the primary shaft precisely and that the shafts are not exposed to any radial pressure. Also be sure to use a clutch that corresponds in terms of size and weight to the pump shaft and that does not convey any balance error to the pump. To avoid any damage to the clutch, be sure not to hit or bump the pump shaft, either directly or indirectly, during clutch assembly.
6. There must be 1 to 1.5 mm of clearance space between the two halves of the clutch. Make sure that the rotating clutch parts do not touch or rub against any of the stationary pump or motor parts (axially)!
7. Check that all pipe connections and lines have been connected tension-free and are properly sealed and absolutely tight. We recommend the use of seals made of either copper, aluminium or synthetics. Under no circumstances may you use hemp, hemp-like materials or any material similar thereto!

8. The letters on the pump stand for:

A = suction connection

S = nozzle connection

R = return/runback (not separately highlighted)

9. Make sure that the return line leads back to the tank. Any blockage in this line will keep the pump's pressure control devices from functioning.
10. Clean all pipes/lines of dirt and/or of metal particles before connecting them to the pump.
11. First fill the pump's suction connection -A- with oil. Then attach the suction line to the threaded connection -A-.
12. Connect the nozzle line to - S – and the return line to - R -.
13. Remove the cover screw plug for manometer 1. (Please refer to drawing.)
14. Open all shut-off valves along the lines and on the tank. Check whether there is enough oil in the tank. Make sure that the pump's and/or the system's overflow/pressure relief valve is completely relaxed as described in points 17, 18 and 19.

Initial Operation

15. Make sure that the pump rotates in the direction of the arrow. Connect the E-motor in accordance with the electrical data on the plate and switch it on. As a precaution and to protect the motor, be sure to use a protective motor switch equipped with an overload release!
16. Close the opening for manometer 1 with either the cover screw plug or with the manometer itself as soon as the oil starts running out of the opening. (Please refer to the drawing.)
17. To put the desired operating pressure remove the covering screw first. (Please refer to the drawing.)
18. Screw a manometer to the connection for manometer 1 and 2 - providing that this step has not already been carried out.
19. Use a hexagon key to turn the slotted setting/adjusting cheese head screw which was under the cover screw on the suction side of the pump.
Turn the setting screw to the right (clockwise) to increase the pressure.
Turn the setting screw to the left (counterclockwise) to decrease the pressure.

When setting the desired operating pressure, assure that a setting is chosen which is within the permissible pressure range of the built-in pressure spring (a pressure stage between 1 and 4).

	<u>Pressure Range</u>	<u>Factory Setting</u>
1:	from 1 - 4 bar	2 bar
2:	from 2 - 9 bar	6 bar
3:	from 6 - 25 bar	15 bar
4:	from 15 - 40 bar	15 bar

Attention! Setting a higher operating pressure (one that exceeds the designated pressure range) will result in the pressure spring blocking and in pressure surges, which, in turn, will rapidly lead to pump failure.

For oil-burning applications, close the burner's solenoid valve before setting or resetting pump pressure.

20. After the pressure has been set via the setting/adjusting screw, the electric motor must be switched off. Subsequently replace the cover screw plus washers over the pressure setting/adjusting screw and replace the screw plug with sealing at the connection for manometer 1 and 2.

Inspection and Maintenance

21. Pump and motor pump group are maintenance free.
22. Insert a suction filter on the pump's suction side. Check the system's suction filter regularly for dirt and to assure that it has not become loose. Use a mesh size of between 80 and 100 microns for EL-type heating oils.
When using heavy fuel oils and to allow for the high fiber content of such oils, use a mesh size of 540 microns. However, we do recommend that 100-micron mesh be used during the first 1 to 2 months (especially when you are using long, welded pipes) until all welding residues (either in the form of cinder or other particles left over from welding) have been filtered out. Once this initial period is over, you can switch over to 540-micron mesh.
23. Make sure that the vacuum at the pump's suction connection (measured at the vacuum meter connection - refer to drawing) is no greater than -0.4 bar.
24. If the pump is being run with supply/feed pressure, this pressure must not exceed 5 bar.

Trouble Shooting

25. Pump noise can occur when
 - a) the vacuum on the suction side is too great due to a clogged filter,
 - b) the suction lines are not properly sealed,
 - c) the suction line is too narrow or too long.
27. In the interest of efficiency, we recommend that a reserve pump be kept handy near the burner.

Note:

According to the specifications of DIN EN 12514-1, Paragraph 4.3.3, the user must equip the overall system with a lower limit restrictor (such as an electric pressure control device).

These installation and maintenance instructions are intended solely for the use of a specialist!

Installation, Maintenance and Operating Instructions

for hp- internal gear pumps
Series UHE-AX

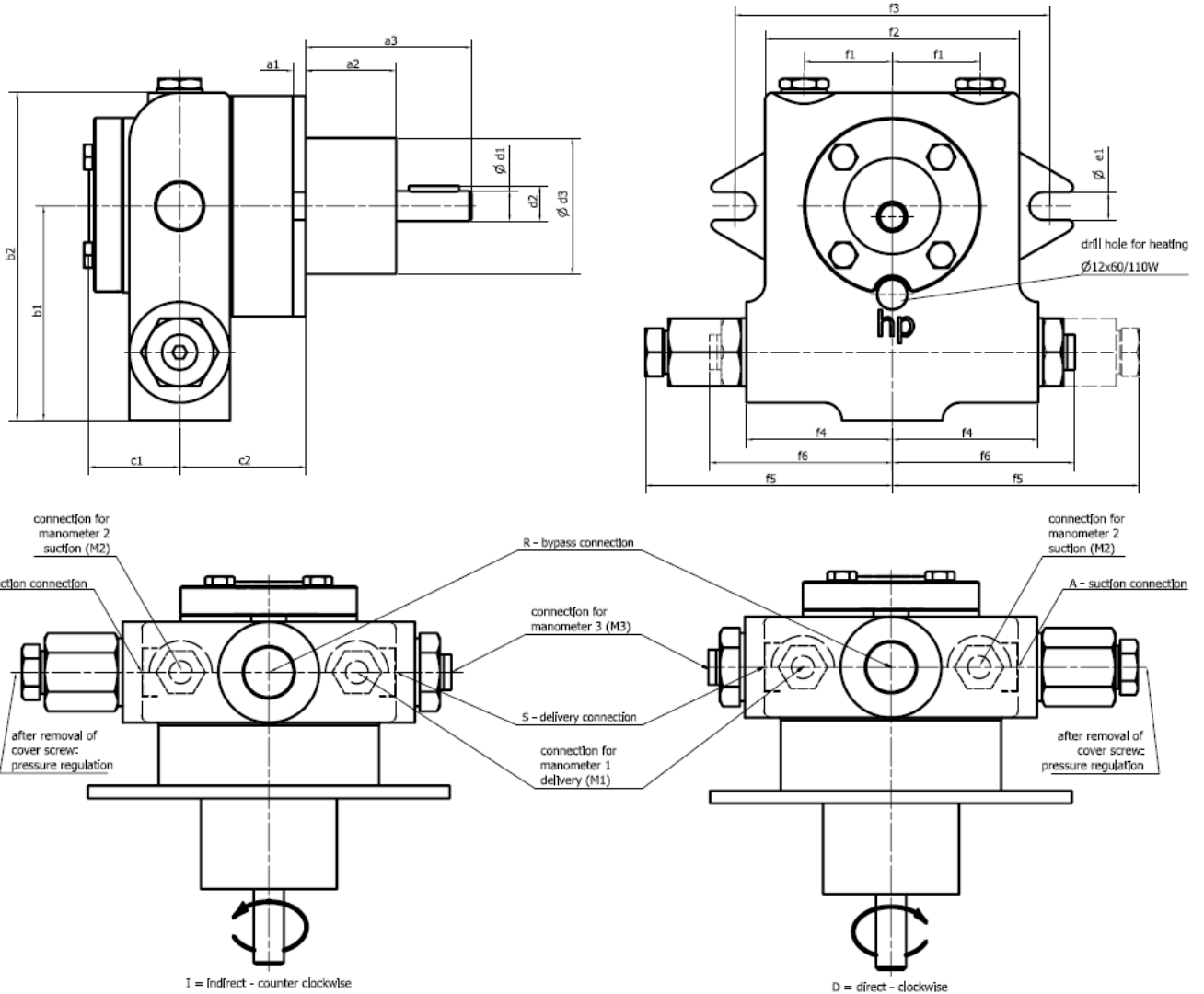

Measure table

Typ	a1	a2	a3	b1	b2	c1	c2	d1	d2	d3
UHE-A2-PZ	5	36	66	85	130	36	50	12	13,5	54
UHE-A3-P	5	36	66	85	130	36	54	12	13,5	54
UHE-A4-M	5	36	66	85	130	36	58	12	13,5	54
UHE-A5-GZ	5	36	66	85	130	36	64	12	13,5	54

Typ	e1	f1	f2	f3	f4	f5	f6	S; A; R	M1; M2	M3
UHE-A2-PZ	11	35	101	125	58	98	72,5	1/2"	1/4"	1/8"
UHE-A3-P	11	35	101	125	58	98	72,5	1/2"	1/4"	1/8"
UHE-A4-M	11	35	101	125	58	98	72,5	1/2"	1/4"	1/8"
UHE-A5-GZ	11	35	101	125	58	98	72,5	1/2"	1/4"	1/8"

All hp pumps are equipped with axial face seals made of Viton which can resist pressures of up to 5 bar and withstand temperatures of up to 150°C.

The axial face seals are relieved of pressure on the suction side of the pump.

See graph for maximum pressure load of the axial face seal, i.e. of the suction side in dependence with the temperature.

Article-No.: 0190015

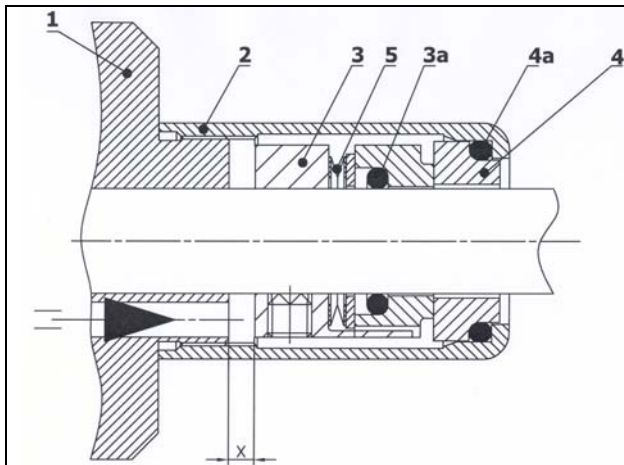
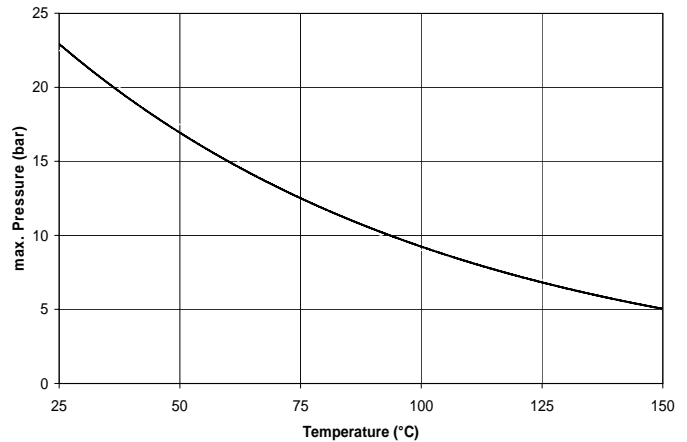

1. Pump housing
2. Union nut
- 3a. O-Ring
3. Tapet
- 4a. O-Ring
4. Counter ring
5. Spring

X Installation size*

* - In case of replacement can be found in the documents accompanying the valid installation dimension

Article-number: 0190015

Accessories

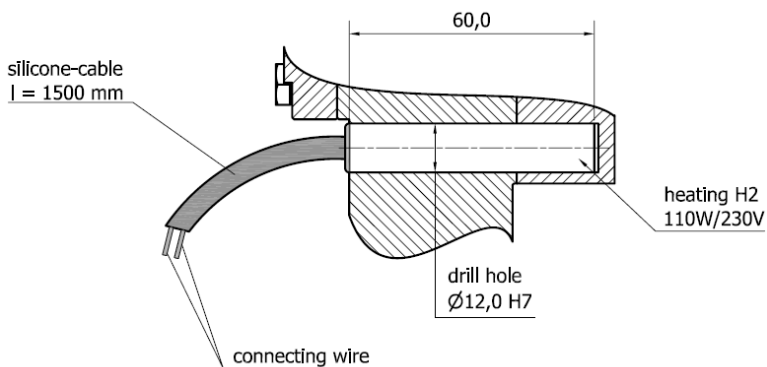

hp-electric standby and companion Heater

All hp Industrial Pumps Series UHE-AX can be equipped with electric heating, Series H2, at the factory.

We strictly recommend using this option for HFO application.