

RM6, RM12, RM15, RM25, RM30 SERIES

**SAFETY SOLENOID GAS VALVES OF
NORMALLY OPEN TYPE WITH MANUAL
OPENING, 1/2" 3/4" 1" CONNECTIONS
AND OPENING PRESSURE UP TO
500mbar**

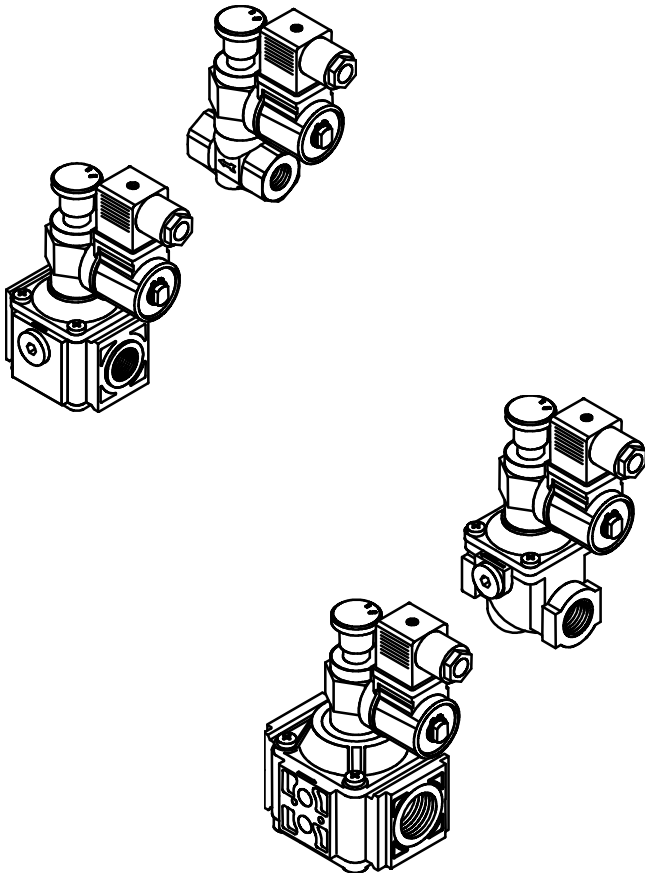

GENERAL DESCRIPTION

This series of solenoid gas valves is of normally open type, fast acting, supplied with alternate current and suitable for civil and industrial applications.

These valves are usually mounted on the inlet of control and regulating devices (e.g. pressure regulator, pressure switch, control valves) and are directly connected to a backfire detector which closes the valve by means of an electrical signal to the coil if gas is detected, preventing in this way possible gas loss. In order to restore the fuel flow, manually readjust the valve to normally open position.

Besides these features – which usually mark other valves available on the market – our RM... valves are also provided with an inbuilt gas regulating cock. In this way it is not necessary to mount a ball cock on the valve inlet, with undoubted economic advantages during installation.

TECHNICAL FEATURES

- Approvals:	EC Reg. no.: 0063AS4838
- Class:	A
- Group:	2
- Supply voltage (1):	220-240Vac / 50-60Hz 110Vac / 50-60Hz
- Operating temperature range:	-10°C / +60°C
- Opening and closing time:	≤1s
- Mounting position:	vertical (not upside-down) or horizontal
- Body:	press-forged brass (RM6), or die-cast aluminium (RM12, RM15, RM25, RM30)
- Weight:	see attached table
- Flow rate:	see attached diagram

(1) The above mentioned are the approved executions. However, versions with different supply voltage operating with direct or alternate current are available on request.

INSTALLATION

- Respect the applicable national and European standards (e.g. EN60335-1) regarding electrical safety.
- Assemble the valve to the installation so that the arrow on the valve body has the same direction as the fuel flow.
- During the assembly of the valve to the installation piping, avoid twisting on the sheath and always use an hexagonal key to be fitted to the valve body.
- Make sure that no foreign matters have entered the valve body.
- Make sure that the max. fuel input pressure never exceeds the value appearing on the label.

DIRECTIONS FOR MANUAL VALVE OPENING

Raise the knob and rotate it clockwise until the indicator "1" reaches the locking pivot (Fig.1). In this way the valve is adjusted in normally open position and fuel flow is allowed.

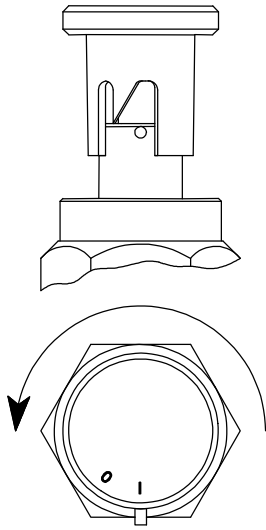

Fig. 1

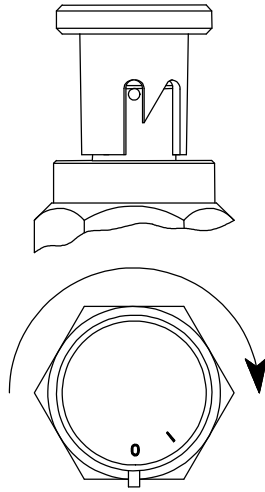
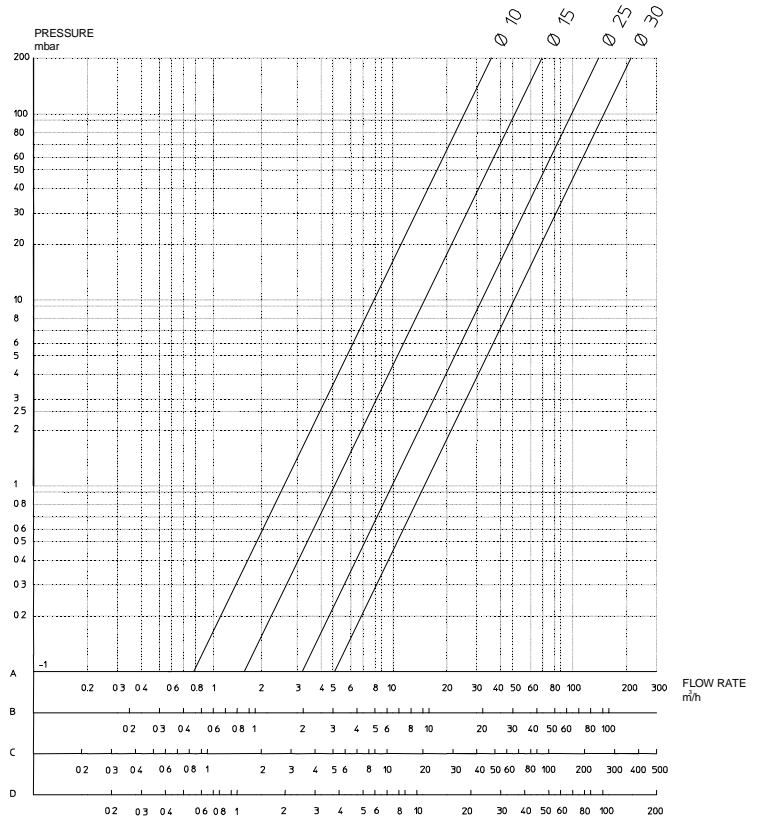

Fig. 2

DIRECTIONS FOR MANUAL VALVE CLOSING

Rotate the knob counter-clockwise until the indicator "0" reaches the locking pivot. In this position the knob drops and the valve closes (Fig.2).

DIAGRAM



A: standard flow rate m³/h of NATURAL GASdr 0.554

B: standard flow rate m³/h of LPGdr 1.54

C: standard flow rate m³/h of TOWN GASdr 0.411

D: standard flow rate m³/h of AIR dr 1

OVERALL DIMENSION

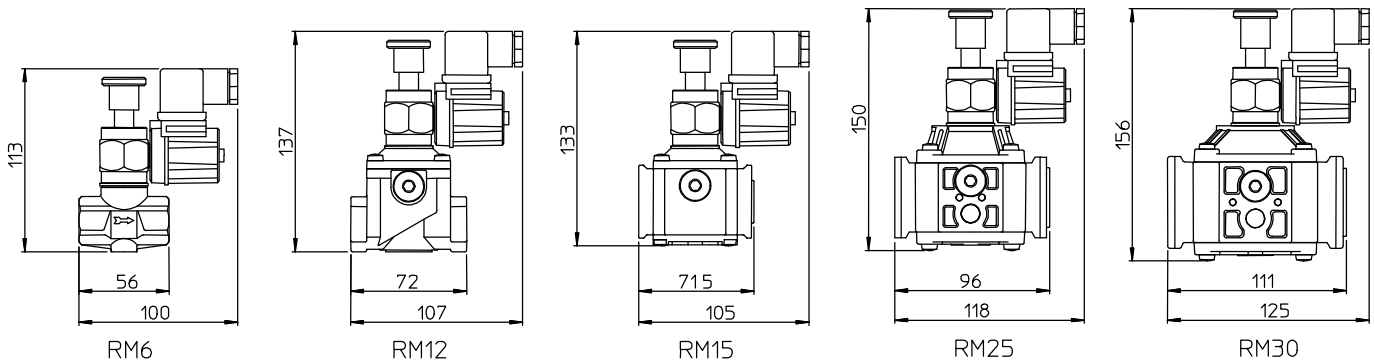

SUMMARY TABLE

Type	Operating pressure (mbar)	Orifice diameter (mm)	Connections	Weight (g)	Consumption (VA)		Flow rate (m ³ /h natural gas with ΔP 2.5mbar)
					220-240Vac	110Vac	
RM6	0 ÷ 500	10	G1/2"	592	10	10	4,0
RM12	0 ÷ 500	15	G1/2"	695	10	10	8,0
RM15	0 ÷ 500	15	G1/2"	780	10	10	8,0
RM25	0 ÷ 500	25	G3/4"	1065	10	10	15
RM30	0 ÷ 500	30	G1"	1265	10	10	23