

E6G* ... SERIES

SOLENOID GAS VALVES WITH 1/4", 3/8" AND 1/2" CONNECTIONS AND OPERATING PRESSURE UP TO 1bar

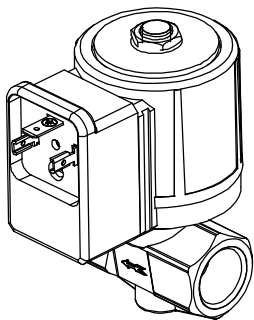
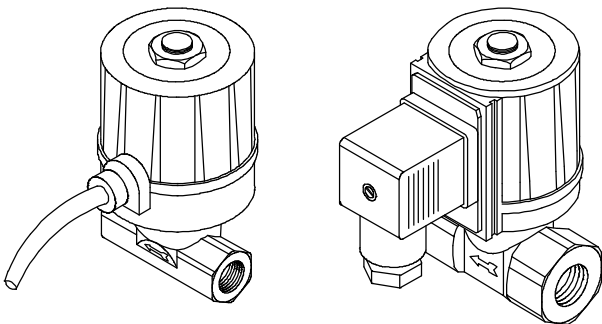
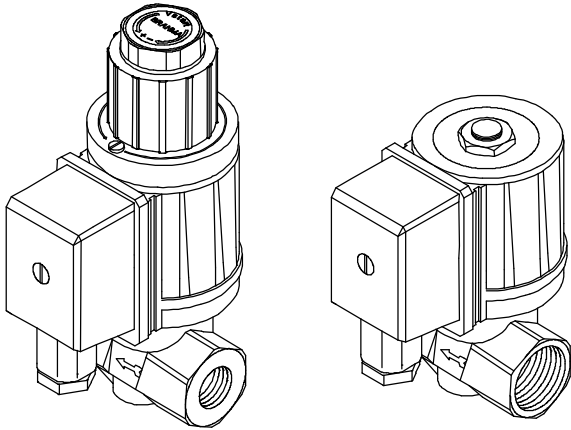

GENERAL DESCRIPTION

This series of solenoid valves is of normally closed type, suitable for civil and industrial applications, supplied with alternate or direct current. These valves are divided into two groups: with 8 mm or 10 mm orifice.

The valves marked with "S" or "L" after their type reference have a coil operating in direct current, which has enabled to make their actions as noiseless as possible.

It is possible to have valves provided with upstream or downstream pressure test point (excluding the ones with G1/4" connection) and, for 10 mm orifice versions only, valves equipped with hydraulic brake unit, enabling slow opening; in this case it is also possible to have an adjustable quick opening initial flow.

The valves of this series, conforming to EN161, have a CE type Certificate (CE Reg. N°63AQ0626) in accordance to the European Directives 90/396 and 93/68.

TECHNICAL FEATURES

Gas type:	1st family, 2nd family, 3rd family
Class:	A B (for E6G*PC version only)
Group:	2
Supply voltage (1):	230 Vac / 50-60 Hz 110 Vac / 50-60 Hz 24 Vdc (for E6G*PC only)
Operating temperature:	-10°C / +60°C -10°C / +125°C (for E6G*PC only)
Closing time:	≤ 1s
Opening time:	≤ 1s (for quick opening versions only)
Mounting:	vertical and horizontal
Body:	die-cast brass

(1) Versions with different supply voltage are available.

INSTALLATION

- Respect the applicable national and European standards (e.g. EN60335-1) regarding electrical safety.
- Assemble the valve to the installation so that the arrow on the valve body has the same direction as the fuel flow.
- During the assembly of the valve to the installation piping, avoid twisting on the sheath and always use an hexagonal wrench to be fitted to the valve body.
- Make sure that no foreign matters have entered the valve body.
- Make sure that the max. fuel input pressure never exceeds the value appearing on the label.

DIRECTIONS FOR E6G*L... VALVES ADJUSTMENT

Flow adjustment

To adjust the gas flow, remove one of the two screws used to fasten the hydraulic brake unit (the non-enamelled one, marked with 4 in Fig.1) and rotate the whole brake unit clockwise to reduce the flow or in the opposite direction to increase it.

Opening time adjustment

After removing the top protection by rotating it anticlockwise, act on the adjustment screw marked with 1 in Fig.1; by rotating it clockwise, the opening time becomes longer, by rotating it in the opposite direction, the opening time becomes shorter.

Quick opening initial flow adjustment

After removing the top protection by rotating it anticlockwise, if you rotate the nut marked with 2 in Fig.1 clockwise, the initial flow will be reduced; if you rotate the same nut anticlockwise, the initial flow will be increased.

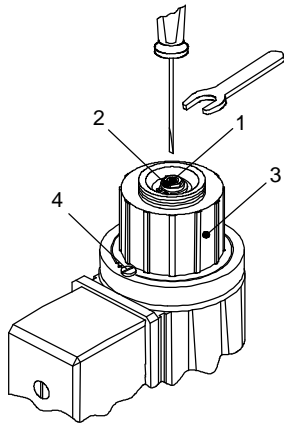

Fig. 1

DIRECTIONS FOR E6G*SR... VALVES ADJUSTMENT

Flow adjustment

Rotate the screw marked with 1 in Fig.2 clockwise to reduce the flow, rotate it in the opposite direction to increase the same.

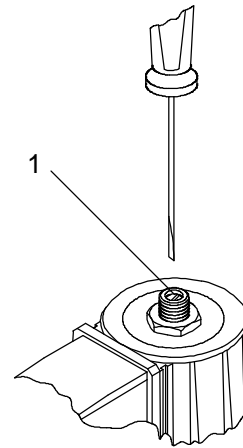
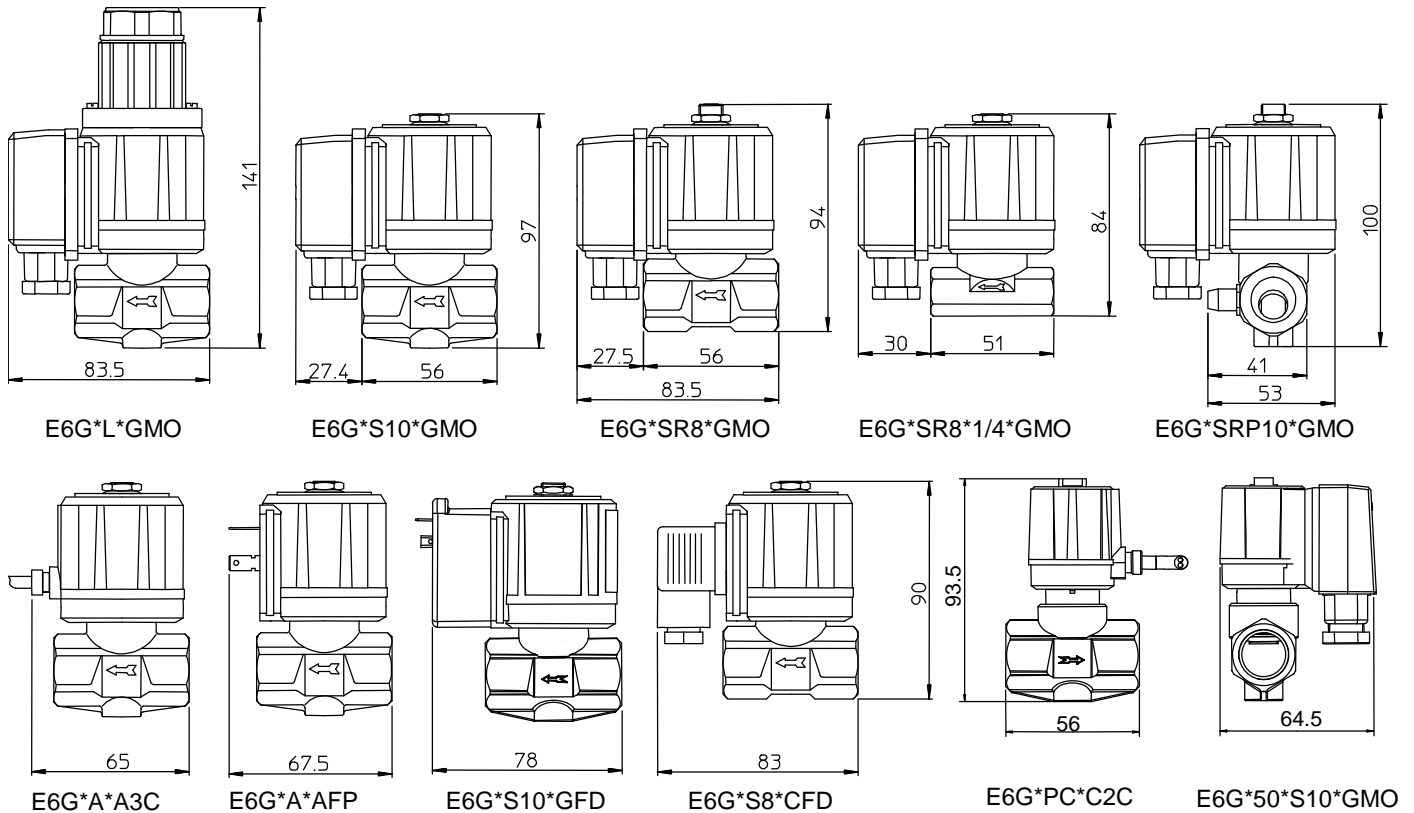

Fig. 2

OVERALL DIMENSIONS



FIXING ACCESSORIES (for E6G*PC... versions for gas hobs only)

Inlet connection with filter and fixing bracket: "I1"

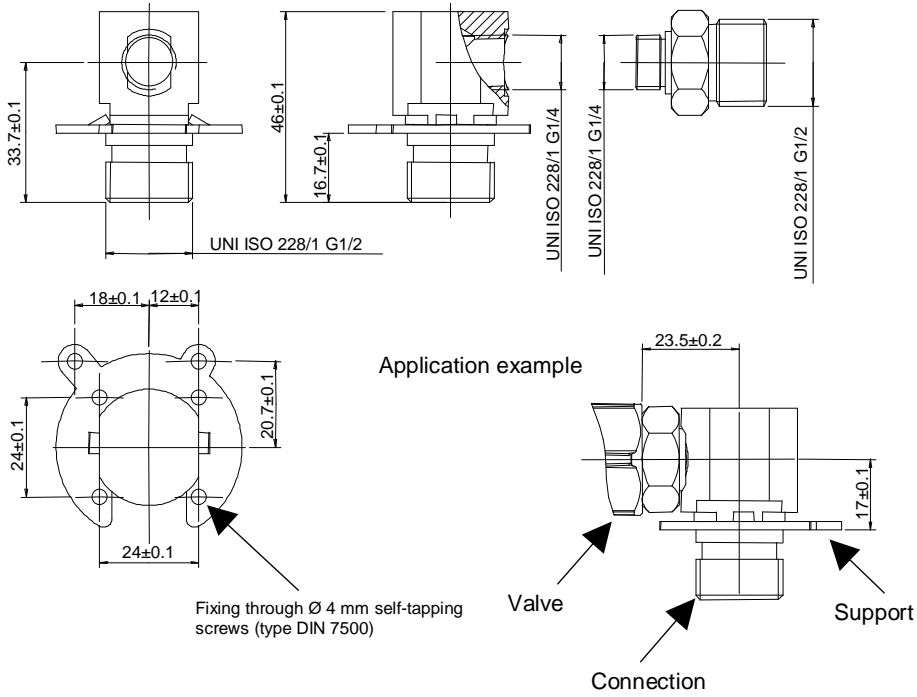

Outlet connection G1/2 – G1/2: "U"

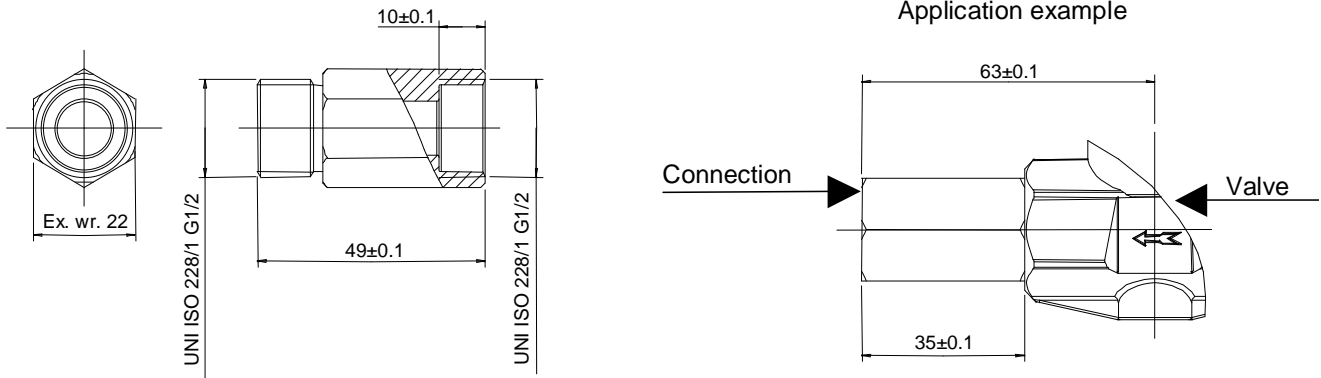

Part reference example "E6G*SP*CFD*I1*U"

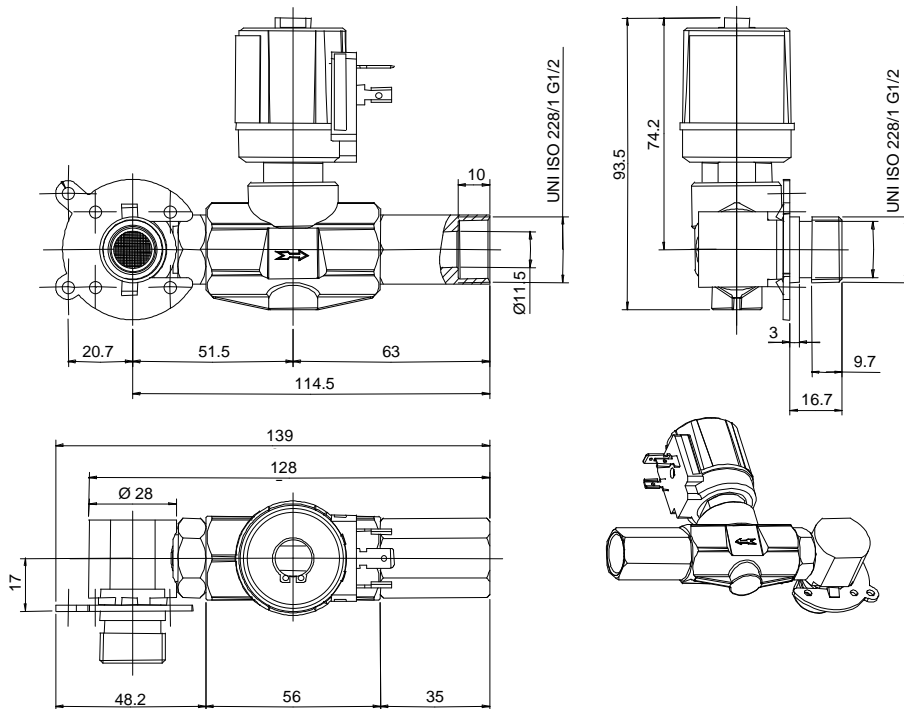

DIAGRAM

PRESSURE DROP
mbar

$\varnothing 8$ $\varnothing 10$

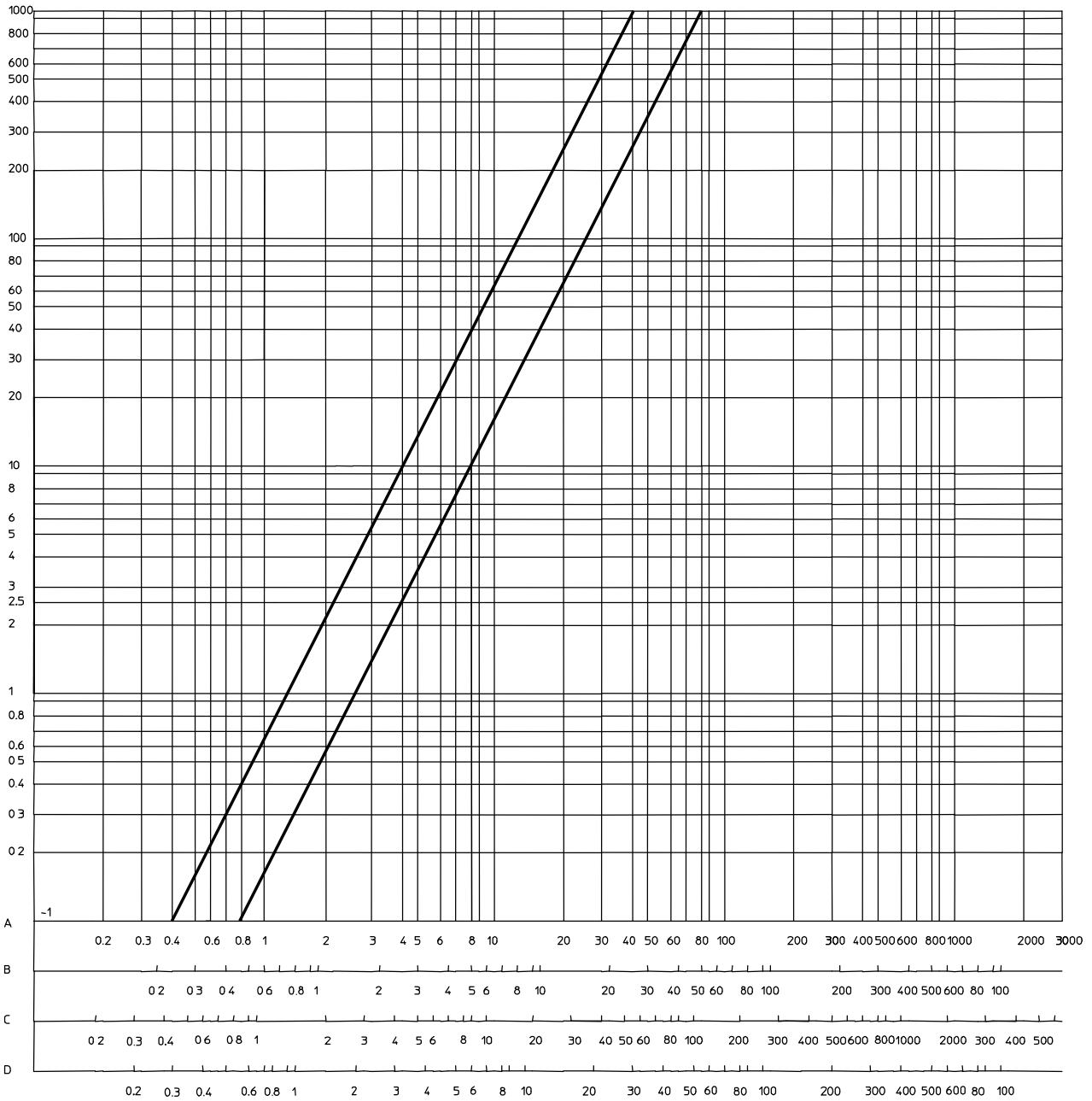

FLOW RATE
m³/h

- A : Standard flow rate m³/h of NATURAL GAS relative density 0.554
- B : Standard flow rate m³/h of LPG relative density 1.54
- C : Standard flow rate m³/h of TOWN GAS relative density 0.411
- D : Standard flow rate m³/h of AIR relative density 1

SUMMARY TABLE

Type	Operating pressure (mbar)	Orifice diameter (mm)	Connections	Weight (g)	Coil	Consumption (VA) 230V	Consumption (VA) 110V	Flow rate (m ³ /h natural gas with ΔP2.5mbar)	Pressure test point option
E6G*S10	0 ÷ 500	10	G3/8"	760	BE6*G..	20	18	3.9	yes
E6G*S10	0 ÷ 500	10	G1/2"	730	BE6*G..	20	18	3.9	yes
E6G*S10	0 ÷ 500	10	G3/8"	740	BE6*C..	20	18	3.9	yes
E6G*S10	0 ÷ 500	10	G1/2"	710	BE6*C..	20	18	3.9	yes
E6G*50*S10	0 ÷ 50	10	G3/8"		BE7*G..	7	7	3.9	yes
E6G*50*S10	0 ÷ 50	10	G1/2"		BE7*G..	7	7	3.9	yes
E6G*50*S10	0 ÷ 50	10	G3/8"		BE7*C..	7	7	3.9	yes
E6G*50*S10	0 ÷ 50	10	G1/2"		BE7*C..	7	7	3.9	yes
E6G*SR10	0 ÷ 500	10	G3/8"	765	BE6*G..	20	18	3.9	yes
E6G*SR10	0 ÷ 500	10	G1/2"	735	BE6*G..	20	18	3.9	yes
E6G*SR10	0 ÷ 500	10	G3/8"	745	BE6*C..	20	18	3.9	yes
E6G*SR10	0 ÷ 500	10	G1/2"	715	BE6*C..	20	18	3.9	yes
E6G*50*SR10	0 ÷ 50	10	G3/8"		BE7*G..	7	7	3.9	yes
E6G*50*SR10	0 ÷ 50	10	G1/2"		BE7*G..	7	7	3.9	yes
E6G*50*SR10	0 ÷ 50	10	G3/8"		BE7*C..	7	7	3.9	yes
E6G*50*SR10	0 ÷ 50	10	G1/2"		BE7*C..	7	7	3.9	yes
E6G*L	0 ÷ 200	10	G3/8"	865	BE6*G..	20	18	3.9	yes
E6G*L	0 ÷ 200	10	G1/2"	835	BE6*G..	20	18	3.9	yes
E6G*S8	0 ÷ 1000	8	G1/4"	620	BE6*G..C	20	18	2	no
E6G*S8	0 ÷ 500	8	G3/8"	725	BE6*G..C	20	18	2	yes
E6G*S8	0 ÷ 500	8	G1/2"	695	BE6*G..	20	18	2	yes
E6G*S8	0 ÷ 1000	8	G1/4"	640	BE6*G..	20	18	2	no
E6G*S8	0 ÷ 1000	8	G3/8"	745	BE6*G..	20	18	2	yes
E6G*S8	0 ÷ 1000	8	G1/2"	715	BE6*G..	20	18	2	yes
E6G*S8	0 ÷ 1000	8	G1/4"	620	BE6*C..	20	18	2	no
E6G*S8	0 ÷ 1000	8	G3/8"	725	BE6*C..	20	18	2	yes
E6G*S8	0 ÷ 1000	8	G1/2"	695	BE6*C..	20	18	2	yes
E6G*SR8	0 ÷ 1000	8	G1/4"	625	BE6*G..C	20	18	2	no
E6G*SR8	0 ÷ 500	8	G3/8"	730	BE6*G..C	20	18	2	yes
E6G*SR8	0 ÷ 500	8	G1/2"	700	BE6*G..	20	18	2	yes
E6G*SR8	0 ÷ 1000	8	G1/4"	645	BE6*G..	20	18	2	no
E6G*SR8	0 ÷ 1000	8	G3/8"	750	BE6*G..	20	18	2	yes
E6G*SR8	0 ÷ 1000	8	G1/2"	720	BE6*G..	20	18	2	yes
E6G*SR8	0 ÷ 1000	8	G1/4"	625	BE6*C..	20	18	2	no
E6G*SR8	0 ÷ 1000	8	G3/8"	730	BE6*C..	20	18	2	yes
E6G*SR8	0 ÷ 1000	8	G1/2"	700	BE6*C..	20	18	2	yes
E6G*A10	0 ÷ 950	10	G3/8"	675	BE6*A3C	20	18	3.9	yes
E6G*A10	0 ÷ 950	10	G1/2"	645	BE6*A3C	20	18	3.9	yes
E6G*A10	0 ÷ 950	10	G3/8"	695	BE6*AFD	20	18	3.9	yes
E6G*A10	0 ÷ 950	10	G1/2"	665	BE6*AFD	20	18	3.9	yes
E6G*PC	0 ÷ 30	10	G3/8"		BE7*C..			3.9	no
E6G*PC	0 ÷ 30	10	G1/2"		BE7*C..			3.9	no

TYPE REFERENCE

E6G *50* S R P 10*1/2 * G FD 7 230/50-60

Type _____

Version _____

Type	Description
Without letter	Standard
50	Version with Pmax. 50mbar

Type of opening (quick/slow) _____

Type	Description
A	Quick opening. (For versions with 10mm body orifice only)
S	Quick opening, noiseless.
L	Slow opening, noiseless. Version inclusive of flow rate adjustment. (For versions with 10mm body orifice only)

Flow adjustment _____

Valve fitted with equipment for flow adjustment.

Pressure test point _____

Valve fitted with pressure test point with G1/4" connections.

Type of body _____

Type	Connections	Orifice diameter
8*1/4	G1/4"	8 mm
8*3/8	G3/8"	8 mm
8*1/2	G1/2"	8 mm
10*3/8	G3/8"	10 mm
10*1/2	G1/2"	10 mm

Supply voltage _____

Type	Description
110/50-60	110 Vac / 50-60 Hz
230/50-60	230 Vac / 50-60 Hz

Pressure test point position _____

Type	Description
5	Downstream left
6	Downstream right
7	Upstream left
8	Upstream right

Type of connection _____

Type	Description
2C	Connection by two-core cable - IP65.
3C	Connection by three-core cable - IP65.
FP	Connection by flat fast-on terminals.
FD	Connection by fast-on for DIN43650 plug - IP65 (GFD IP40).
MO	Connection by terminal board - IP54.
MOC	Connection by terminal board (short conveyors) - IP54 (except for 50mbar version).

Type of power supply _____

Type	Description
A	Supply in alternate current (except for 50mbar version).
C	Supply in direct current.
G	Supply in alternate current, but the valve operates in direct current thanks to an inbuilt rectifier bridge (for versions with connection type "MO", "MOC" and "FD" only).

E6G *PC* C

Type _____

Version _____

Valve exclusively prearranged for use as safety valve in gas hobs. Valve in class "B".

Type of power supply _____

Type	Description
C	Supply in direct current.
G	Supply in alternate current, but the valve operates in direct current thanks to an inbuilt rectifier bridge (for versions with connection type "MO" only).

2C 24Vdc

Supply voltage _____

Type	Description
24Vdc	24 Vdc

Type of connection _____

Type	Description
2C	Connection by two-core cable - IP65.
3C	Connection by three-core cable - IP65.
FP	Connection by flat fast-on terminals.
FD	Connection by fast-on terminals for DIN43650 plug - IP65.
MO	Connection by terminal board - IP54.