

# TEMPERATURE DIGITAL CONTROL SYSTEM SERIES 964

**BRAHMA**

MICROCONTROLLER-BASED DEVICE  
FOR BURNER IGNITION AND  
THERMOREGULATION PROCESS IN  
ATMOSPHERIC GAS BOILERS

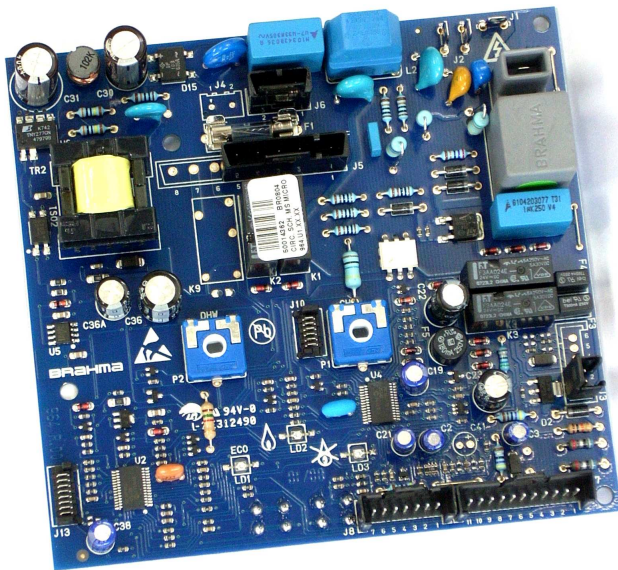

## DESCRIPTION

These electronic systems are suitable for operating cycle and temperature control in closed-chamber and open-chamber gas boilers, fitted with atmospheric gas burner.

## GENERAL FEATURES

This control board is provided with the following features:

- CE type certification, PIN 5151BT3706, in accordance with gas appliance directive 90/396/CEE and the following amendment of Directive 93/68/EC;
- In compliance with EN 298:2003 (European standard for automatic gas burner control and flame monitoring systems);
- Safe to touch single electrode for ignition and flame monitoring with on board ignition device;
- Possibility of multiple ignition attempts;
- Electrical or manual reset from lockout position;
- Control of the boiler parts (system circulator, fan, 3 way valve, modulating gas valve, flow switch/flow meter, air pressure switch or flue gas thermostat, safety thermostats, NTC probes, room thermostat etc.);
- Driving the Brahma gas valve VCM01 with or without pressure sensor;
- Automatic identification of the boiler type equipped (open or closed combustion chamber);
- Controls, adjusters and signals through two potentiometers, three leds and two switch. Possible connection with LCD panel type LCD5;
- Use of NTC contact and/or immersion probes for temperature measurement (up to two);
- Use of a normally closed contact safety thermostat or outgoing temperature probe with two NTC elements;
- 4kV and 5mm PELV (Protective Extra Low Voltage) insulation on the Printed Circuit Board surface between components connected to the mains supply and low voltage controls;
- Flame modulation by means of a proportional, integral and derivative (PID) digital electronic system;
- Varistor protecting the system from voltage transients which may be generated in the mains supply;
- EMC system;
- Connection with remote control device Opentherm compatible on the same pole of the room thermostat;
- Connection with RS-232 interface.

## TECHNICAL DATA

<b>Supply voltage:</b>	230V - 50/60Hz
<b>Operating temperature range:</b>	-20°C ÷ +60°C
<b>Humidity:</b>	95% max at 40°C not condensing
<b>Protection degree:</b>	IP 00
<b>Consumption (without loads):</b>	
Stand-by state:	8VA
Safety time:	12VA
Running position:	10VA
<b>Weight:</b>	max 170 g
<b>Dimensions:</b>	135x125x31(*) mm
(*) Variable with the height of the push button	

## INTEGRATED TEMPERATURE CONTROL SYSTEM

The integrated temperature control systems are usually customized (according to customer's requirements) as far as operation and control of the boiler parts are concerned. However, for a more detailed description, hereunder we will refer to the system series 964 in its "standard" configuration.

The main technical features are described here below.

### Classification codes according to EN298:

Character	Specification	Code
1°	Fanned and atmospheric	B
2°	Direct ignition of the main burner	M
3°	Non-volatile lockout	L
	Volatile lockout	V
	Recycling	C
4°	Non-volatile lockout	L
	Volatile lockout	V
5°	Fixed times	X
6°	System for non-permanent operation	N

### Timings (\*):

waiting time (TW):	1,5 ÷ 60 s
pre-purge time (TP):	1,5 ÷ 60 s
safety time (TS):	3 ÷ 60 s
spark ignition time (TSP):	(TS - 1) s
response time on flame failure:	< 1 s
post-purge time:	0 ÷ 1800 s
inter-waiting or inter-purge time:	0 ÷ 240 s
lockout due to air flow failure at start	3 ÷ 120 s
lockout due to flame fault	0 ÷ 60 s
pre-ignition time	0 ÷ 60 s

(\*) The above times correspond to guaranteed values. Actual values may differ from declared ones, as waiting (TW) or pre-purge (TP) may be longer and safety time (TS) shorter.

**Ignition attempts :** 1 ÷ 10

### Load rating:

Gas valve Brahma type VCM01:	0,4A <sub>DC</sub>	
Fan 230V <sub>AC</sub> :	0,4A <sub>AC</sub>	cos φ ≥ 0.4
3 way valve 230V <sub>AC</sub> :	0,1A <sub>AC</sub>	cos φ ≥ 0.4
System circulator 230V <sub>AC</sub> :	0,5A <sub>AC</sub>	cos φ ≥ 0.4
Auxiliary output 230V <sub>AC</sub> :	0,5A <sub>AC</sub>	cos φ ≥ 0.4

The power supply of the board is filtered so the total sum of the current allowed by the board for the loads is 1.2 A. The sum of loads must be less than this value.

**Max. cable length of external components:** ≤ 1 m

**Internal fuse:** 2 A 250 V<sub>AC</sub> quick act

### Flame control:

The flame detection device makes use of the rectification property of the flame. The detection probe is a safe touch output and the device is more sensitive to flame at start-up.

Minimum ionisation current: 0.5μA<sub>DC</sub>  
on request 1.2μA<sub>DC</sub>

Maximum ionisation current:  
phase sensitive: 8.1μA<sub>DC</sub>  
voltage on electrode 193V<sub>RMS</sub>  
no phase sensitive (option no. 2 N): 3.8μA<sub>DC</sub>  
voltage on electrode 97V<sub>RMS</sub>

Recommended ionisation current:  
3 ÷ 5 times the min. ionisation current

Maximum cable length: 1 m

Minimum insulation resistance of detection electrode and cable to earth: ≥ 50 MΩ

Max. electrode stray capacitance: ≤ 1 nF

Max. short circuit current: < 200μA<sub>AC</sub>

### Ignition device:

Peak ignition voltage at 30pf loading : 15 kV  
on request 18 kV

Peak current : 800mA

Spark repetition frequency : 25 Hz  
on request < 25 Hz

Max. length of the high voltage cable: 2 m

Recommended spark gap : 2-4 mm

Spark energy : 20 mJ

## CONNECTIONS

### High voltage connections (230V<sub>AC</sub>)

Function	Reference	Type
Main supply	J6 2 poles	STELVIO CFM/...A STOCKO MKS 2820
System circulator Fan 3 way valve	J5 5 or 8 poles	STELVIO CFM/...A STOCKO MKS 2820
Safety earth	J1,J2,J11	Male fast-on 4.8x0.8
Spark ignition / flame detection	TR1	Male fast-on 2.8x0.5
Auxiliary output	J4 2 poles	JST XA (B02(5.0)B-XASK-1)

### Low voltage connections (PELV)

Function	Reference	Type
Gas valve VCM01*xx series	J3 2 poles	LUMBERG 2,5 MSF
Gas valve VCM01*Sxx series	J3 6 poles	LUMBERG 2,5 MSF

Function	Reference	Type
Outgoing NTC probe or 1 <sup>st</sup> NTC thermistor	J8 7 poles	LUMBERG 2,5 MSF or JST XA (B07B-XASK-1)
Safety thermostat or 2 <sup>nd</sup> NTC thermistor		
Air pressure switch (closed chamber)		
Flue gas thermostat (open chamber)		
Room thermostat or remote control device Opentherm compatible	J7 7 poles	LUMBERG 2,5 MSF or JST XA (B11B-XASK-1)
DHW flow-switch or flow-meter		
DHW NTC probe		
Water pressure switch		
Connection for RS-232 interface or LCD panel	J9 8 poles	LUMBERG MICS or Molex PICOFLEX

### Safety thermostat

The system is perfectly safe against possible overheating in the primary system by means of a safety thermostat realized by a normally closed contact thermostat (manual or automatic reset) or by temperature probe with double NTC thermistors connected to the 964. The thermostat switching can immediately lead the system to non-volatile lockout.

In case of double NTC probe the system monitors the primary circuit temperature and the consistency of the two thermistors of the probes; if the consistency test fails, the system turns off the burner and waits until this condition become right. If the temperature of the primary circuit is higher than a fixed threshold, the system goes in non-volatile lockout condition. Before attempting a new starting cycle, it is necessary to reset the board from lockout.

### Temperature measuring probes

The system can control up to two temperature detection probes, the primary system outgoing water probe must necessarily be always available, the remaining one (domestic hot water probe) can be available or not, depending on the settings (software) selected by the user and the comfort desired.

Please note that the primary system outgoing water probe can also operate as a limit thermostat, by inhibiting any heat demand if the water temperature exceeds the preset limit temperature.

Recognizing threshold when probe is interrupted

Higher than >60KΩ

Recognizing threshold when probe is short-circuited

less than 700Ω

### System circulator

The 964 board can be fitted to any type of circulator with 230V<sub>AC</sub> supply voltage. Circulator lockout prevention function is available according to customer's requirements.

### 3 way valve / DHW circulator

The system can control either boilers provided with an electric 3 way valve (230V<sub>AC</sub>), boilers fitted with a hydraulic 3 way valve, or boilers equipped with a Domestic Hot Water circulator (to be connected on the same contact as the 3 way valve). The different operation modes will be determined by suitable software settings. 3 way valve or DHW circulator lockout prevention function is available according to customer's requirements.

### Fan

The system can control a standard fan with 230V<sub>AC</sub> supply voltage. Several types of fan are compatible with the board, but it is advisable to know their features to ensure the correct choice.

### Gas valve

The system is able to drive a Brahma gas valve series VCM01\*xx or VCM01\*Sxx at 24V<sub>DC</sub> with/without gas pressure sensor. If the valve has the gas pressure sensor (VCM01\*Sxx) the system checks the gas sensor by monitoring its fatigue and the correct function. If the valve is without the gas pressure sensor (VCM01\*xx) is necessary the use of a diaphragm to limit the maximum output pressure of the gas.

### Air pressure switch or flue gas thermostat

The 964 board is realized for automatic identification of the combustion chamber type in use (closed or open chamber). The air pressure switch checks the circulation of combustion products in the combustion chamber and allows boiler ignition only if the fan is operating and the draft is regular; it also ensures the boiler safety shutdown if one of these conditions fails during operation. In open-chamber boilers the air pressure switch can be replaced by a flue gas thermostat, which uses the same connector but different pin.

### Water pressure switch

It ensures that the primary circuit pressure is within the required operation range. In case the pressure is too low, the system cancels any heat demand.

### Domestic Hot Water flow-switch or flow-meter

The 964 board can be connected to a device able to signal the domestic water extraction. This signal can be generated by a flow sensor (flow-switch or flow-meter): in this case the 3 way valve (if available) or a pump dedicated to the domestic hot water circuit is electrically controlled by the system Higher than 60

### Room thermostat

The room thermostat (or chrono-thermostat) is connected to the 964 board by two wires (24V<sub>DC</sub>). The system is designed to operate with a contact isolated from the power supply line. The room thermostat can be an on/off thermostat or an Opentherm<sup>®</sup> compatible device.

## Settings and visualization

The 964 board is provided with two potentiometers, three leds and two push buttons, which have different functions in accordance to customer's requirements. The board can also be connected to the LCD control panel, type LCD5, provided with additional four push button and LCD display with backlight

## RS-232 serial communication

The board 964 is fitted with a 8-pole connector for RS-232 serial communication (J9): this feature is useful to update the board software directly on the field (without necessarily disassembling the board from the boiler or disconnecting it from the power supply), and to display the system data on an personal computer.

## DIRECTIONS FOR INSTALLATION

- This digital control system is a safety device and must not be modified. Responsibility and guarantee of the manufacturer will be debarred if the controller is opened by the user;
- The system is designed to stay in running position for less than 24 hours (system for non-permanent operation). Reaching this limit causes a regulation shutdown in order to allow the controller to check its efficiency;
- The system can be mounted in any position;
- Avoid exposing the system to dripping water;
- The appliance in which this system is mounted must provide adequate protection against the risk of electric shock (at least IP 20);
- In order to optimize the controller duration it's preferable a quite low ventilation temperature;
- Before installing or replacing the system, make sure that type, times and code are those required.

## ELECTRICAL INSTALLATION

- Respect the applicable national and European standards (e.g. EN 60335-1/EN 50165).;
- Connect live and neutral correctly (in case the device is phase sensitive option no. 3 – no letter); the non-observance of live-neutral polarity causes flame detection failures;
- Before starting the system check the cables carefully: wrong connection can damage the devices and compromise the safety of the installation;
- Connect and disconnect the control system **only after switching off power supply;**
- Avoid placing control signal cables close to power cables;
- Make sure the device is connected to the grounding system correctly;
- This system is supplied with internal fuse, but it must be protected by a fuse at least on the phase connection (see technical data).

## CHECKING AT START

Check the system before the first start up and also after overhaul or a long period of non operation. Before any ignition attempt make sure that the combustion chamber is empty, then make sure that:

- If the starting attempt occurs without gas supply, the controller locks out at the end of the safety time (TS) of the last ignition attempts;
- When the gas flow stops (while system is in operation state) the power supply of the solenoid gas valves is interrupted, a new ignition cycle is performed and at the end of the previous attempts the lockout state is reached;
- Operating times and cycle are suitable to the used controller;
- The intervention of the regulators, limiters or safety devices causes a shut down of the controller according to the application type;
- The level of the flame signal is high enough (for flame signal test see the following figure);

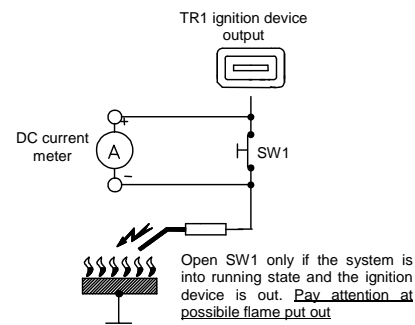

## ACCESSORIES

The system can be supplied with:

- Connectors and terminals for wiring;
- Wiring for RS-232 connection;
- Contact temperature probes Brahma series ST03, ST04, ST07 and ST11;
- Single NTC thermistor immersion temperature probes Brahma series ST06, ST6B, ST09 and ST10;
- Double NTC thermistor immersion temperature probe Brahma series ST12;
- Chronothermostat series BAT1;
- Remote control devices Opentherm compatible Brahma type Encrono OT1 or Encrono OT2;
- Plastic casing;
- LCD control panel type LCD5;
- Ignition and flame detection electrodes series SA, RS and RB.

For technical features of the accessories, see the relative technical sheet available in our web site [www.brahma.it](http://www.brahma.it).

## OPERATING CYCLE

The following description is related to the 964 board with standard operative mode.

The starting cycle of the burner begins against a heat demand and if the water temperature is lower than the preset value. At every start the system goes to a self-checking of its own components and identifies the type of the boiler combustion chamber in use. A fault in the flame amplifier (flame simulation) prevents the burner from starting. In case of a closed-chamber boiler, the board energizes the fan only if the air pressure switch is

in "no-air-flow" position; when it switches into "air-flow" position, the pre-purge time TP begins, at the end of which the gas valve is energized, the ignition device is activated and the safety time TS begins. In case of an open-chamber boiler, the waiting time TW begins only if the flue gas thermostat is in the operative state (contact in normally closed position). If a flame signal is detected at the end of TS time, the thermoregulation temperature process will begin, and the burner flame will be modulated in order to reach the same water temperature as the preset value. If no flame signal is detected within the safety time, at the end of TS time the gas valve will close. If the number of attempts is completed the non volatile lockout condition occurs, otherwise another ignition attempt is carried out. To reset the system from the lockout state, press the related push-button. If hot water demand still occurs, the boiler will start a new ignition cycle; if the conditions leading to lockout still occur, the boiler will go back to lockout. The boiler keeps on running until either heat demand stops, or one of the safety devices switches on, or the flame extinguishes.

#### **Operating cycle variations**

The possible operation cycle variations based on the application are as follows:

##### **Option (12): Lockout due to flame simulation**

If the system detects flame signal at start-up or during the waiting (TW) or pre-purge time (TP), it proceeds to the lockout condition immediately or with a delay time of nn seconds.

##### **Option (13): No air flow or flue gas thermostat is operative at start-up**

If the air pressure switch or the flue gas thermostat are in open state at start-up, the device goes to the lockout state after nn delay seconds.

##### **Option (14): Air flow failure or flue gas thermostat operates in running state**

If the air pressure switch or the flue gas thermostat operates in running state the lockout condition is immediately reached.

##### **Option (15): Flame failure in running state**

Lockout condition is immediately reached on flame failure during running state.

##### **Option (16): Ignition attempts**

The system performs multiple ignition attempts. The number of attempts is set upon request.

##### **Option (17): Pre-ignition time**

The ignition device starts to operate at the end of the TW/TP time for nn second before the beginning of the safety time (TS)

##### **Option (18): Post-purge time**

Time interval between any shut-down and fan switching off (the time is set on request).

A new heat demand ends the post-purge time.

##### **Option (19): Inter-waiting or inter-purge time**

The device starts an additional waiting or pre-purge time, after an unsuccessful ignition attempt and before starting a new ignition attempt (TW-TP/TS cycle).

##### **Option (20): Combustion safety device monitoring mode**

If the flue gas thermostat opens while the system is in stand-by state, the fault is identified.

##### **Option (21): Safety thermostat device monitoring mode**

If the safety thermostat operates while the system is in stand-by state, the lockout condition is reached.

#### **System reset from the lockout condition**

##### **Non volatile lockout**

Reset is carried out only by the local or remote push button.

##### **Volatile lockout**

Reset is carried out by power supply interruption.

#### **Domestic Hot Water mode**

If the Domestic Hot Water circuit is available, the relative demand can be detected by a water flow-switch, or flow-meter or tank probe. The system can be used in various boilers type like the DHW instantaneous mono or bithermal appliance, the internal or external hot water tank. The operative DHW mode will be according to customer's requirements.

#### **Heating mode**

Heat demand can be carried out by the room thermostat or by the remote control device Opentherm compatible. The operative heating mode will be according to customer's requirements .

#### **Circulator overrun**

Every time the boiler switches off, the circulator keeps on running for a short time, tis function can be customized.

#### **Antifreeze mode**

When the outgoing water temperature of the primary system drops below a fixed threshold the boiler will start. This function can be customized.

#### **Minimum output gas pressure**

If the system uses a gas valve without the gas pressure sensor (VCM01\*\_xx,) a particular operative mode is required for the minimum gas pressure calculation. This operative mode can be carried out according to the customer's requirements .



#### **NOTES FOR THE DISPOSAL OPERATION**

The controller contains electronic components and it must not be disposed of as a domestic waste. For the disposal operation refer to the local rules concerning special waste.

## DENOMINATION OF BOARD TYPE 960

The following codification plan explains the signification of the code shown on the label of the board

### 964 . H W . S . X

**H:** letter/s attributed to the customer and it's within the internal competence of BRAHMA

**W:** progressive number for customer that indicates a particular hardware and software whose composition is specified in a customized technical document

**S:** revision index of the safety firmware (00, 01 ... progressive order)

**X:** revision index of the thermoregulation firmware (00, 01 ... progressive order)

Hereunder a list of the total features and options of the 964 board which the customer uses to identify the suitable device required.

These options aren't reported on the label of the board but in the technical document of the device.

series     type                                  option  
**964 . (1) (2) (3) (4) (5) (6) (7) (8) (9) (10) (11) (12) (13) (14) (15) (16) (17) (18) (19) (20) (21)**

**(1) hardware type referred to the final appliance**

- 1** Device for appliance without electrical 3 way valve and equipped with gas valve VCM01\*xx
- 2** Device for appliance with electrical 3 way valve and equipped with gas valve VCM01\*xx
- 3** Device for appliance without electrical 3 way valve and equipped with gas valve VCM01\*Sxx
- 4** Device for appliance with electrical 3 way valve and equipped with gas valve VCM01\*Sxx

**(2) Type of lockout state**

- M** Non volatile lockout state (standard version)
- E** Volatile lockout state

**(3) Type of power supply connection**

- No letter Phase sensitive device (standard version)
- N** No phase sensitive device

**(4) Type of available safety thermostat**

- No letter NTC temperature probe with two sensible elements (standard version)
- S** Normally closed contact safety thermostat

**(5) Ignition voltage peak value**

- No letter 15 kV (standard version)
- H** 18 kV

**(6) Type of connectors for low voltage connections**

- No letter Lumberg series 2,5 MSF (standard version)
- Z** JST series XA

**(7) Waiting or pre-purge time**

- TW/TP nn** Duration of the waiting or pre-purge time expressed in seconds

**(8) Safety time**

- TS nn** Duration of the safety time expressed in seconds

**(9) Minimum ionisation current:**

- No number 0.5µA<sub>DC</sub> (standard sensibility)
- 1,2** 1.2µA<sub>DC</sub>

**(10) Ignition device operative mode**

- No letter Ignition device operates during the "spark ignition time" TSP (standard version)
- B** Ignition spark is switched off when flame presence is detected

**(11) Spark ignition frequency**

- No letter 25 Hz (standard version)
- nn** Value less 25Hz

**(12) Behaviour with flame simulation signal or fault of the flame amplifier**

- No letter The device doesn't start the ignition cycle (standard version)
- K** The device proceeds to the lockout condition
- Knn** The device proceeds to the lockout condition after nn seconds

**(13) Absence or insufficient air flow / flue gas thermostat in open state at the start-up**

- No letter The device doesn't start the ignition cycle (standard version)
- Qnn** The device proceeds to lockout condition after nn seconds

**(14) Air flow / flue gas thermostat failure in running state**

- No letter The device carries out a safety shut down and a new ignition cycle isn't performed (standard version)
- R** The device goes to the lockout condition

**(15) Flame failure in running state**

- No letter The device carries out one or more ignition attempts (standard version)
- V** The device goes to the lockout condition

**(16) Ignition attempts**

- No letter Single ignition attempt (standard version)
- Ynn** Multiple ignition attempts (nn number of ignition attempts)

**(17) Pre-ignition time**

- No letter Not available (standard version – ignition device starts to operate at the begin of the safety time)
- Jnn** The ignition device starts to operate nn seconds before the beginning of the safety time

**(18) Post-purge time**

- No letter No post-purge time (standard version)
- PTnn** The device performs a post-purge time of nn seconds

**(19) Inter-wating or inter-purge time**

- No letter No inter-purge time (standard version)
- Inn** The device performs an inter-purge time of nn seconds

**(20) Flue gas thermostat monitoring mode**

- No letter The board monitors the flue gas thermostat only if heat demand is present
- C** The board monitors the flue gas thermostat always during operative state

**(21) Normally closed contact safety thermostat monitoring mode**

- No letter The board monitors the safety thermostat only if heat demand is present
- S** The board monitors the safety thermostat always during operative state

**DIMENSIONS**

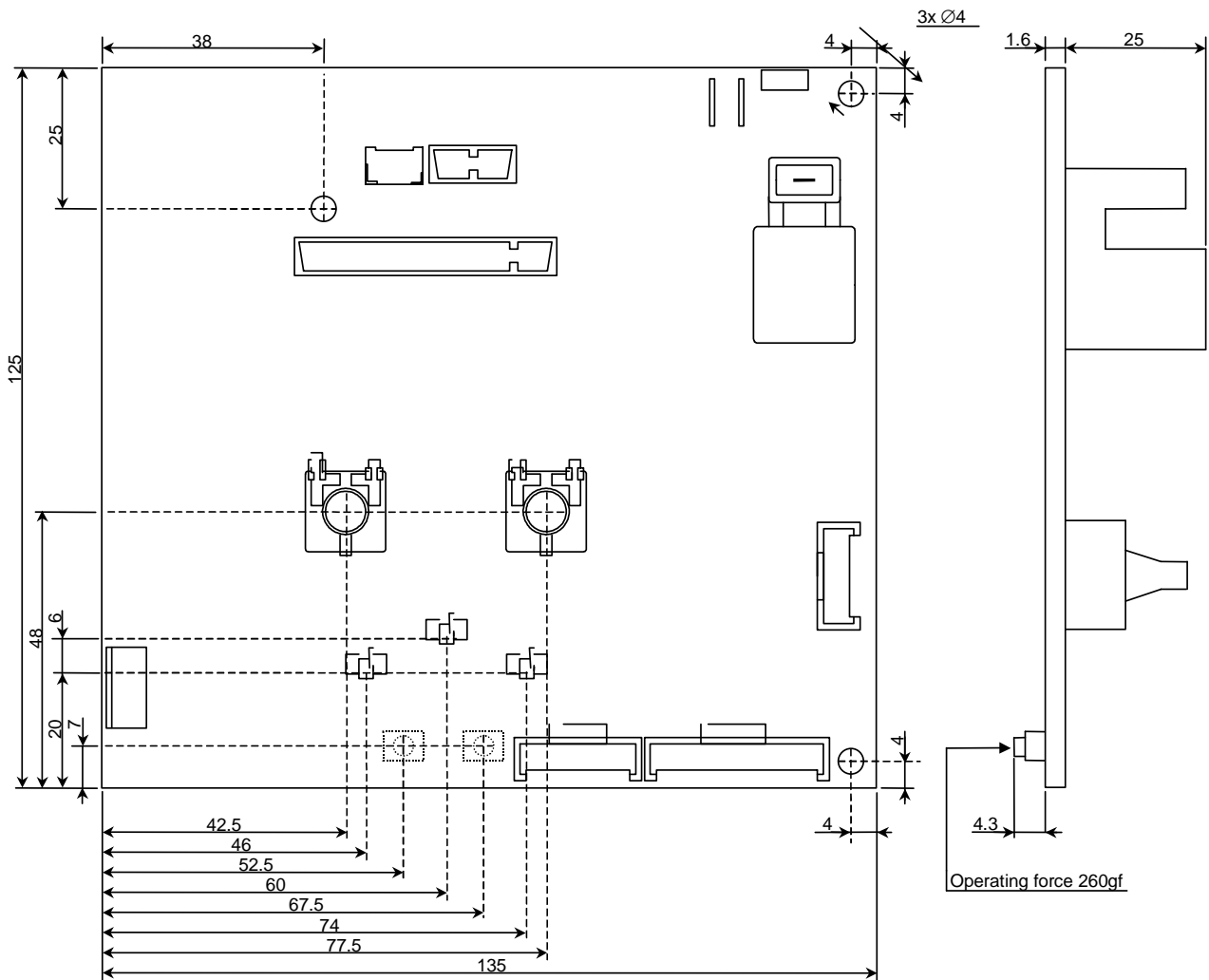

Measurement unit: mm – Tolerance: ± 0.2mm

# WIRING DIAGRAM

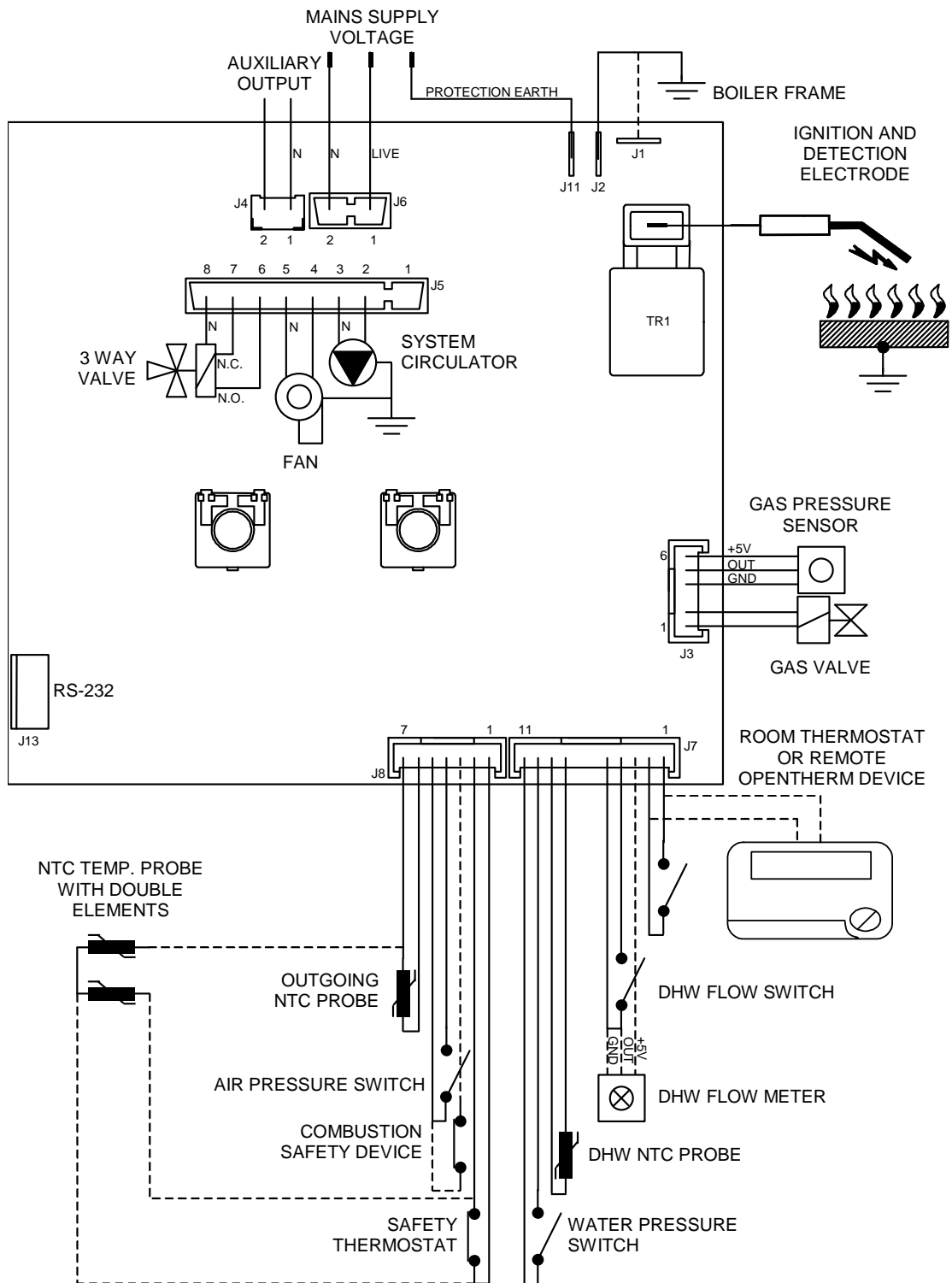



**OPERATING CYCLE DIAGRAM OF THE STANDARD VERSION**

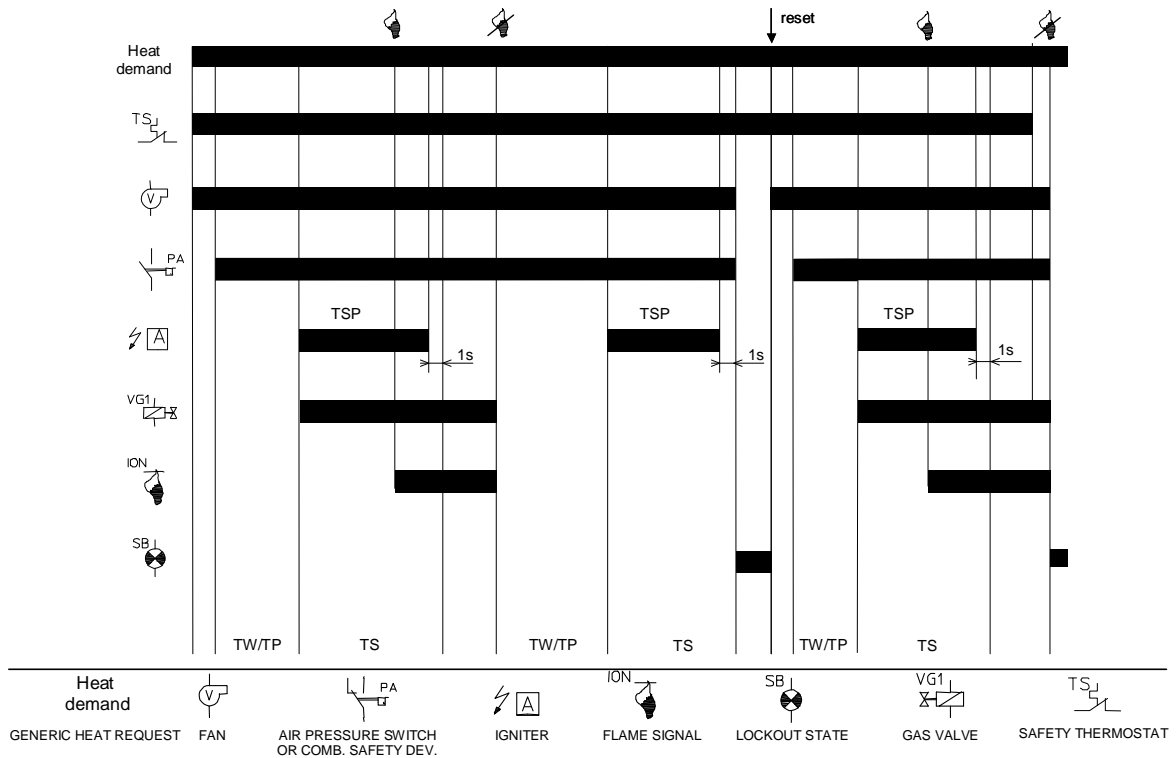

**OPERATING CYCLE DIAGRAM FOR OPTIONS Qnn – K – Knn – R – V**

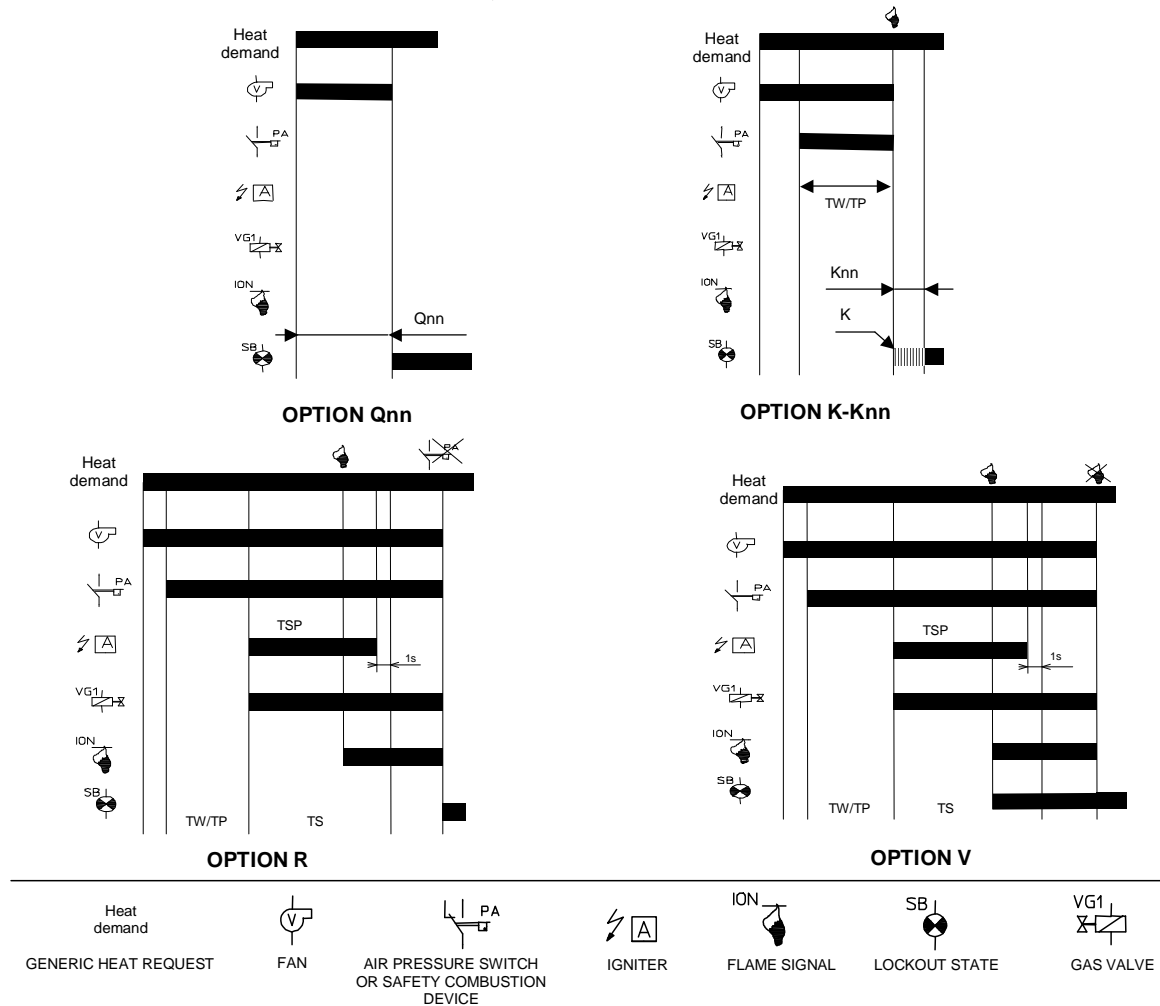

**OPERATING CYCLE DIAGRAM WITH OPTIONS Jnn – Ynn – Inn**

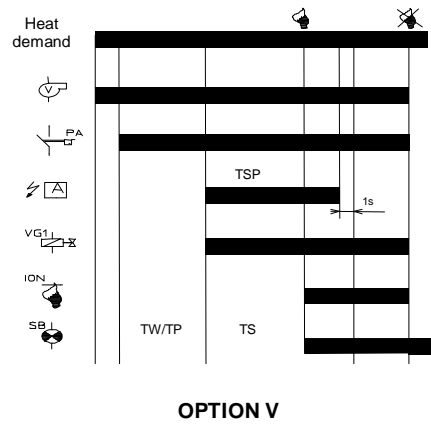
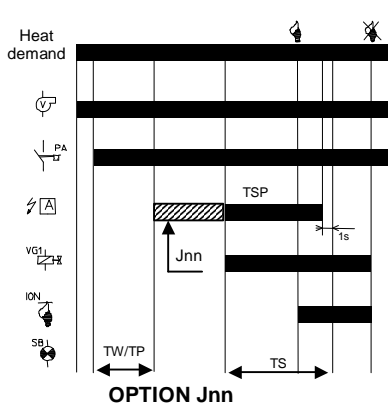

**OPERATING CYCLE DIAGRAM WITH OPTIONS PTnn - B**

