

10260A HercuLine[®] Actuator Installation, Operation and Maintenance Manual

ISO 9002

62-86-25-06

Rev. 6
2/03

Copyright, Notices, and Trademarks

Printed in U.S.A. – © Copyright 2003 by Honeywell
Revision 6 – February, 2003

WARRANTY/REMEDY

Honeywell warrants goods of its manufacture as being free of defective materials and faulty workmanship. Contact your local sales office for warranty information. If warranted goods are returned to Honeywell during the period of coverage, Honeywell will repair or replace without charge those items it finds defective. The foregoing is Buyer's sole remedy and is **in lieu of all other warranties, expressed or implied, including those of merchantability and fitness for a particular purpose**. Specifications may change without notice. The information we supply is believed to be accurate and reliable as of this printing. However, we assume no responsibility for its use.

While we provide application assistance personally, through our literature and the Honeywell web site, it is up to the customer to determine the suitability of the product in the application.

ATTENTION

The emission limits of EN 50081-2 are designed to provide reasonable protection against harmful interference when this equipment is operated in an industrial environment. Operation of this equipment in a residential area may cause harmful interference. This equipment generates, uses, and can radiate radio frequency energy and may cause interference to radio and television reception when the equipment is used closer than 30 m to the antenna(e). In special cases, when highly susceptible apparatus is used in close proximity, the user may have to employ additional mitigating measures to further reduce the electromagnetic emissions of this equipment.

CE CONFORMITY

This product conforms with the protection requirements of the following European Council Directive: 89/336/EEC, the EMC directive and 73/23/EEC, the Low Voltage Directive. Conformance of this product with any other "CE Mark" Directive(s) shall not be assumed.

Industrial Measurement and Control

Honeywell
1100 Virginia Drive
Fort Washington, PA 19034

About This Document

Abstract

This manual contains instructions for installation, operation and maintenance of the 10260A Series Actuators.

References

Honeywell Documents

The following list identifies all Honeywell documents that may be sources of reference for the material discussed in this publication.

Document Title	ID #
Specification	62-86-03-10
Model Selection Guide	62-86-16-17

Non-Honeywell Documents

The following list identifies select non-Honeywell documents that may be sources of reference for the material discussed in this publication.

Title	Author	Publisher	ID/ISDN #
Process Instrumentation Terminology		ISA	ANSI/ISA S 51.1 – 1879 (R1993)

Contacts

World Wide Web

The following lists Honeywell's World Wide Web sites that will be of interest to our customers.

Honeywell Organization	WWW Address (URL)
Corporate	http://www.honeywell.com
Industrial Measurement and Control	http://www.honeywell.com/imc
International	http://www.honeywell.com/Business/global.asp







Telephone

Contact us by telephone at the numbers listed below.

Organization	Phone Number
United States and Canada Honeywell	1-800-423-9883 Tech. Support 1-888-423-9883 Q&A Faxback 1-800-525-7439 (TACFACS) Service

Symbol Definitions

The following table lists those symbols that may be used in this document to denote certain conditions.

Symbol	Definition
	This CAUTION symbol on the equipment refers the user to the Product Manual for additional information. This symbol appears next to required information in the manual.
	WARNING PERSONAL INJURY: Risk of electrical shock. This symbol warns the user of a potential shock hazard where HAZARDOUS LIVE voltages greater than 30 Vrms, 42.4 Vpeak, or 60 Vdc may be accessible. Failure to comply with these instructions could result in death or serious injury.
	ATTENTION, Electrostatic Discharge (ESD) hazards. Observe precautions for handling electrostatic sensitive devices.
	Protective Earth (PE) terminal. Provided for connection of the protective earth (green or green/yellow) supply system conductor.
	Functional earth terminal. Used for non-safety purposes such as noise immunity improvement. NOTE: This connection shall be bonded to protective earth at the source of supply in accordance with national local electrical code requirements.
	Earth Ground. Functional earth connection. NOTE: This connection shall be bonded to Protective earth at the source of supply in accordance with national and local electrical code requirements.
	Chassis Ground. Identifies a connection to the chassis or frame of the equipment shall be bonded to Protective Earth at the source of supply in accordance with national and local electrical code requirements.

Contents

1.	INTRODUCTION	1
1.1	Product Description	1
1.2	Applications.....	1
1.3	Features	1
1.3.1	Non-contact Position Sensing (NCS) with True Shaft Position Indication	1
1.3.2	Slidewire Emulation	2
1.3.3	Film Potentiometer	2
1.3.4	Motor Positioner Board	2
1.3.5	Auto/Manual Switch.....	3
1.3.6	Self-Locking/Releasing Gear Train.....	3
1.3.7	Motor	3
1.3.8	Manual Operation	3
1.3.9	All Position Mounting	3
1.3.10	Field Reversible	3
1.3.11	Customer Connections	3
1.3.12	Warranty	3
1.4	Honeywell Linkage Kits.....	4
2.	SPECIFICATIONS AND MODEL SELECTION GUIDE	7
2.1	Introduction	7
2.2	Specifications	7
2.3	Model Selection Guide.....	11
3.	INSTALLATION	13
3.1	Introduction	13
3.2	Before Starting	13
3.2.1	Unpacking.....	13
3.2.2	Site Selection.....	13
3.2.3	Outline Dimension Drawings	13
3.3	Mechanical Installation	16
3.3.1	General	16
3.3.2	Linkage Set-up.....	16
3.3.3	Projecting Scale Option	20
3.4	Electrical Installation.....	21
3.4.1	General Wiring Recommendations.....	21
3.4.2	Customer Connections.....	22
3.4.3	Power Connections	24
3.4.4	CE Wiring.....	24
3.4.5	0/4-20 mA, 0/1-5 Vdc Input Signal Connections	24
3.4.6	0/4-20 mA, 0/1-5 Vdc Feedback Signal Connections	24
3.4.7	Slidewire Emulator Connections	25

4.	CALIBRATION PROCEDURES.....	27
4.1	Overview	27
4.2	Setting End-of-Travel Limit Switches (actuators mfd. pre-1/1/03).....	27
4.3	Setting End-of-Travel Limit Switches (actuators mfd. after 1/1/03).....	28
4.4	Setting Auxiliary Switches (actuators mfd. pre-1/1/03).....	30
4.5	Setting Auxiliary Switches (actuators mfd. after 1/1/03).....	33
4.6	Non-Contact Sensor	34
4.7	Motor Positioner Board	35
4.7.1	Overview	35
4.7.2	Available Adjustments	35
4.7.3	ZERO and SPAN Adjustments.....	36
4.7.4	Fail-Safe Settings; Loss of Signal (L.O.S.)	36
4.7.5	Filter Settings.....	37
4.7.6	Deadband and Sensitivity Settings	37
4.8	Output Board Calibration	38
4.8.1	0/4-20 mA PWA Output Board	38
4.8.2	Slidewire Emulation	40
4.9	Reversal of Direction (Non contact sensor)	42
4.10	Reversal of Direction (Film Potentiometer)	42
5.	START-UP/OPERATION	45
5.1	Introduction	45
5.2	Operations Checklist	45
6.	OTHER CONTROL FUNCTIONS	47
6.1	Split Range	47
6.2	Master/Slave Arrangement.....	47
6.2.1	Basic Flow Control.....	48
6.2.2	Proportional Flow using Multiple Actuators	49
6.2.3	Split Valve Configuration.....	51
7.	MAINTENANCE	53
7.1	Introduction	53
7.2	Basic Maintenance.....	53
7.2.1	Main Gear Lubrication	53
7.2.2	Spur Gear Lubrication	53
7.2.3	Non-Contact Sensor.....	53
7.2.4	Motor Positioner	53
7.2.5	Replacing the Fuses.....	53
8.	REPLACEMENT/RECOMMENDED SPARE PARTS	55
8.1	Introduction	55
8.2	Motor Kits	55

8.3	Idler Gear Kits	57
8.4	Non-Contact Sensor, Film Potentiometer, Output Board Limit/Aux Switch and CAM Kits	57
8.5	Linkage Parts/Kits	61
8.6	Accessories	61
8.7	Non-Contact Position Sensor Field Upgrade Kits	62
8.8	Honeywell Actuator Linkage Analysis Software (HAL)	65
8.9	Replacement Fuses (Not for Sale)	65
8.10	Film Potentiometer Upgrade Kits	65
9.	TROUBLESHOOTING	69
9.1	Introduction	69
9.2	Troubleshooting Procedures	69
9.2.1	Actuator Current Output does not function.	70
9.2.2	Actuator Slidewire Output does not function.	71
9.2.3	Actuator CW/CCW operation is not correct.....	72
9.2.4	Actuator does not control to the proper position.	73
9.2.5	Auto/Manual Switch does not operate correctly.	74
9.2.6	Actuator CW/CCW Switch does not operate correctly.	75
9.2.7	Actuator Up/Down action does not operate correctly.	76
10.	SALES AND SERVICE	77

Tables

Table 3-1 Recommended Minimum Wire Size _____	21
Table 4-1 Available Adjustments _____	35
Table 9-1 Observable Symptoms of Failure _____	69
Table 9-2 Troubleshooting Current Output _____	70
Table 9-3 Troubleshooting Slidewire Output _____	71
Table 9-4 Troubleshooting CW/CCW Operation _____	72
Table 9-5 Troubleshooting Control Action on Actuator _____	73
Table 9-6 Troubleshooting the Auto /Manual Switch _____	74
Table 9-7 Troubleshooting the CW/CCW Switch _____	75
Table 9-8 Troubleshooting the Up/Down Actuator Action _____	76

Figures

Figure 1-1	10260A Actuator	4
Figure 1-2	10260A Internal View	5
Figure 3-1	Outline and Dimensions of 10261A, -62A, -64A, -66A, -67A, -68A, and -69A Actuators	14
Figure 3-2	Outline and dimensions of 10263A and 10265A Actuators	15
Figure 3-3	Constant Torque Linkage	16
Figure 3-4	Constant Torque Profile	17
Figure 3-5	Variable Torque Linkage	17
Figure 3-6	Variable Torque Profile	18
Figure 3-7	Turnbuckle Linkage Kit	18
Figure 3-8	Pipe Linkage Kit	19
Figure 3-9	Standard 5" Crank Arm	19
Figure 3-10	Projecting Scale Option	20
Figure 3-11	Customer Terminal Connections (Non-contact sensor)	22
Figure 3-12	Customer Terminal Connections (Film Potentiometer)	23
Figure 3-13	Slidewire Connections	25
Figure 4-1	Location of Auxiliary Switches	31
Figure 4-2	End of Travel Limit Switch Settings	32
Figure 4-3	Auxiliary Switch Settings	32
Figure 4-4	Location of NCS Assembly	34
Figure 4-5	Motor Positioner Board	37
Figure 4-6	0/4-20 mA PWA Output Board	39
Figure 4-7	Slidewire Emulation Board	41
Figure 4-8	Switch Jumper for Reversal	43
Figure 6-1	Flow Diagram	48
Figure 6-2	Interconnection Diagram	48
Figure 6-3	Proportional Flow Using Multiple Actuators	49
Figure 6-4	Multiple Actuator Interconnection Diagram	50
Figure 6-5	Interconnection Diagram	51

1. Introduction

1.1 Product Description

Honeywell's 10260A industrially rated rotary control actuators are precision engineered for exceptional reliability, accurate positioning, and low maintenance. Designed for very precise positioning of dampers and quarter turn valves in the power and processing industries, the 10260A performs especially well in extremely demanding environments requiring continuous-duty, high reliability, and low maintenance.

Precise positioning of the actuator is achieved through state-of-the-art motor control and positioning electronics. The motor starts and stops instantaneously, preventing overshoot and hunting. Positioning repeatability of 0.2 % span or better is achievable for extremely tight process control to take full advantage of modern controllers.

A no-burnout synchronous induction motor is combined with a heavy-duty precision machined output worm gear mesh providing a responsive, low maintenance, and non-backdriving actuator. Accidental stalls up to 100 hours can be withstood without damage to the gear train. End-of-travel limit switches are provided as standard to prevent damage to the valve or damper and are backed up by Mechanical stops.

Honeywell electric actuators provide instantaneous response to a demand signal, eliminating system non-linearity due to dead time. Additionally, since the actuator is electric, the costs associated with providing and maintaining a clean, dry air supply are eliminated.

A Heavy duty cast crank arm and precision rod-end bearing is provided with each 10260A actuator. Crank arms can be positioned at any angle on the output shaft and an adjustable radius is provided to allow flexibility in linkage set-up.

All 10260A actuators are equipped with a manual handwheel for operation during loss of power or installation. A local auto/manual handswitch can be provided for local operation and has an “out of auto” contact to annunciate that condition.

1.2 Applications

Honeywell actuators have a long and respected history in the industrial actuator market. 10260A actuators are designed for precision modulation of final control devices such as dampers, vanes, fluid couplings, scoop tubes, fuel/air ratio valves, windbox dampers, and coal mill dampers, and quarter turn valves. The robustness of the design serves as the basis for long-term reliability and reduced operating costs.

1.3 Features

1.3.1 Non-contact Position Sensing (NCS) with True Shaft Position Indication

Introduction

Non-contact position sensing eliminates maintenance problems and nuisance shutdowns that are common with slidewire position sensing. The non-contact position sensor replaces the slidewire and wiper assembly for position sensing. Once calibrated, the non-contacting position sensor requires no maintenance.

Description

The non-contact position sensing assembly consists of a position sensor, an output board, and a bracket as shown in Figure 1-2. The position sensor “spoiler” is connected directly to the output shaft, reflecting true shaft position. As the output shaft rotates, the sensor “spoiler” rotates and the sensing circuit board detects

the change in position. Sensing is accomplished by changing the magnetic field created by the coils in the sensing circuit board. There is no contact between circuit board and spoilers.

1.3.2 Slidewire Emulation

Introduction

A truly unique feature, slidewire emulation allows direct replacement of existing three-wire control actuators without requiring controller changes while gaining all of the advantages of the maintenance-free non-contact sensing. This is ideal for replacement of installed actuators that cause control problems due to slidewire wear.

Description

The slidewire emulation assembly consists of a non-contact position sensor, an output board, and a bracket as shown in Figure 1-2. The position sensor is identical to that described in Section 1.3.1.

A potentiometric voltage from the controller is supplied to the slidewire emulation circuit. This voltage is ratiometrically conditioned with respect to the output shaft position from 0 % to 100 % and is available to the controller. Voltages of 1 Vdc to 20 Vdc are accepted and this device will emulate 100 ohm to 1000 ohm slidewires.

1.3.3 Film Potentiometer

Introduction

Film potentiometer position sensing eliminates maintenance problems and nuisance shutdowns common with slidewire and wiper assembly for position sensing.

Description

The film potentiometer is connected directly to the output shaft reflecting true shaft position. The film potentiometer is 1000 ohms over the actuator's 90 degree travel. Other ohmic values can be accomplished using an appropriate shunting resistor.

1.3.4 Motor Positioner Board

Introduction

The Honeywell Motor Positioner Board accepts a current input signal to provide internal closed loop control of the position of the actuator. The Honeywell Motor Positioner makes positive position control possible with current output controllers.

Description

The Motor Positioner operates raise/lower switch contacts (triacs) which control power to the reversing motor in the actuator. The actuators integral Non-Contact Sensor or Film Potentiometer provide the position feedback signal to the Motor Positioner. Input signal ranges are adjustable from 0.2 Vdc to 1 Vdc, up to 1 Vdc to 5 Vdc. By use of an appropriate shunt resistor, controller current outputs of 4-20 mA dc, 1-5 mA dc, 10-50 mA dc, can be achieved.

Fail-safe features are also provided. On loss of input signal, the Motor Positioner may be preset to drive the motor upscale, downscale, to a particular position, or to stop where it is. In the event of actuator NCS failure (broken wiper) or film potentiometer broken wiper, the Motor Positioner can be set to drive the motor fully upscale or downscale. The Motor Positioner will also accept slidewire input. For master/follower applications, the Motor Positioner will position a "follower" actuator in accordance with a slidewire input signal from a "master" actuator. The ratio between master and follower movement is

adjustable by means of a span control. A bias offset may also be induced between master and follower by means of a zero adjustment. For follower operations in master-follower systems, the master actuator retransmitting slidewire can range from 100 ohms to 1000 ohms. The Motor Positioner is a printed circuit board that is integrally mounted in a 10260A Series Actuator terminal cover. See Figure 1-2. The terminal cover is gasketed to provide weather resistance.

1.3.5 Auto/Manual Switch

The Auto/Manual electric handswitch with auxiliary contacts indicating an "Out-of-Auto" position is available for local electric control.

1.3.6 Self-Locking/Releasing Gear Train

The worm gear output combination is self-locking and self-releasing and maintains position upon loss of power. It is designed to hold greater than two times the rated output torque in a back-driving condition. This design provides superior reliability without the maintenance associated with other self-locking and brake mechanisms.

1.3.7 Motor

A 100 % duty cycle synchronous induction motor provides crisp and responsive movement for precise and accurate positioning. The very low current draw during operation or in stall combined with the no-burnout characteristics of the motor result in low maintenance, high reliability, and long life.

1.3.8 Manual Operation

A manual handwheel is provided for positioning of the actuator during power outages or initial installation. The design of the handwheel allows for positioning of the actuator safely under full load conditions.

1.3.9 All Position Mounting

Honeywell 10260A actuators may be mounted in any orientation making retrofit in tight locations easier.

1.3.10 Field Reversible

NCS: As factory shipped, the actuator is set for counter-clockwise rotation. By changing a jumper and switch, the actuator can be set for clockwise rotation. Re-calibration is not required.

Film Potentiometer: As factory shipped, the actuator is set for counterclockwise rotation. By changing a switch and interchanging the film potentiometer leads, the actuator can be set for clockwise rotation. Re-calibration may be required.

1.3.11 Customer Connections

The 10260A now has dedicated wiring terminals for ease of installation. See section 3.4.2 Customer Connections for specific placement.

1.3.12 Warranty

The 10260A actuator warranty is effective for 30 months from the date of shipment or 24 months from the date of installation whichever comes first.

1.4 Honeywell Linkage Kits

Honeywell turnbuckle and pipe linkage kits are available and are recommended to provide optimal positioning performance. The rod-end bearing connections eliminate all linkage hysteresis giving accurate and repeatable positioning of the final control element. Honeywell has designed a linkage analysis program (HAL) that is used to design linkage set-up.

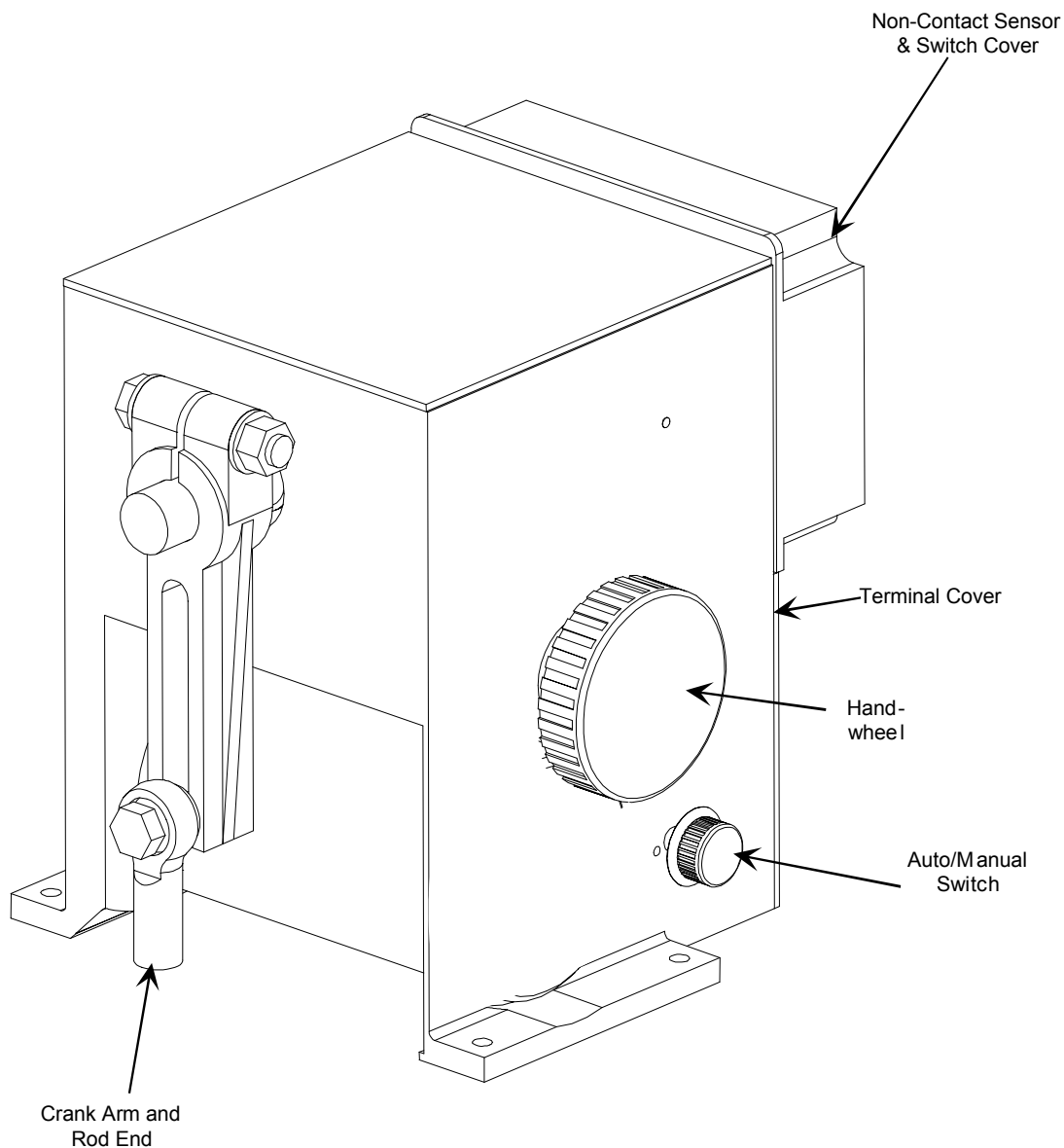

Figure 1-1 10260A Actuator

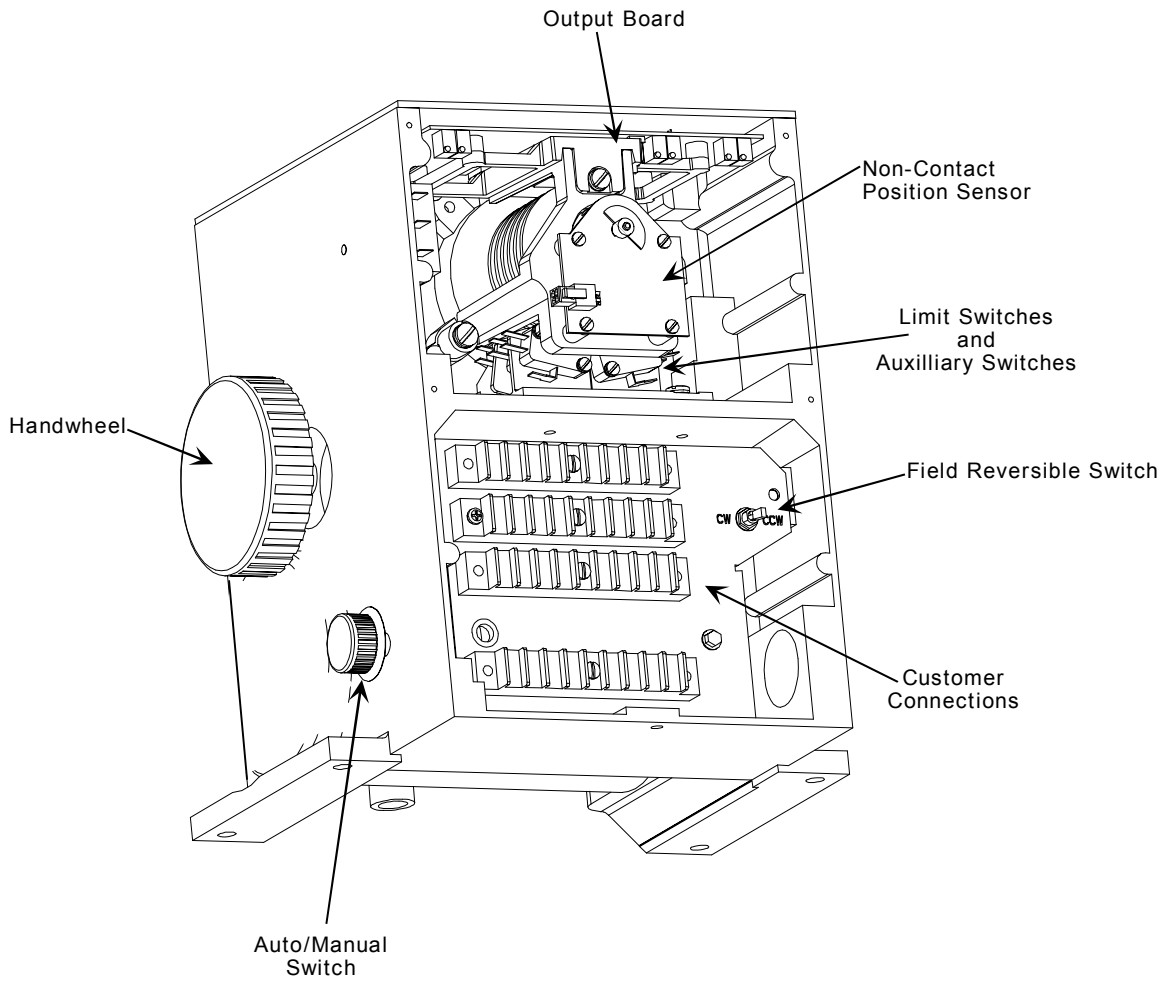

Figure 1-2 10260A Internal View

2. Specifications and Model Selection Guide

2.1 Introduction

This chapter provides the user with the specifications and the Model Selection Guide for the 10260A Series Actuator.

2.2 Specifications

Specification – General

Physical	
Weight	40 lb. (18 kg) net
Enclosure	Precision machined Aluminum alloy casting, finished in light gray powder coat epoxy.
Gear train	Alloy steel, high efficiency steel spur gear primary train with safety fused idler gear. Precision ground, self locking/self releasing worm gear final mesh.
Mechanical stops	To prevent over-travel
Operating Temperature	-30 °C to +85 °C (-20 °F to +185 °F)
Storage Temperature	-40 °C to +93 °C (-40 °C to +200 °F)
Relative Humidity	Fully operable over the range of 0-99 % R.H. non-condensing
Scale	0 % to 100 % corresponding to full crank arm travel.
Crank Arm	Adjustable radii (1-7/16" to a maximum of 5"). Position adjustable through 360° rotation. Optional 12" crank arm adjustable 0-12" radii.
Output Shaft	1" diameter, 1-1/2" long is standard on 10261A, 10262A, 10264A, 10266A, 10267A, 10268A. 1" diameter, 2" long is standard on 10263A, 10265A and 10269A optional on other models.
Rotation	90° degrees between 0 % and 100 % on scale, limited by mechanical stops.
Direction of Rotation	Field selectable via switch and jumper. Default = CCW (determined looking into the shaft)
Manual Handwheel	Provides a means of positioning the actuator in the event of a power failure or set-up.
Lubrication	Texaco Starplex 2 EP Grease
Fuses	Bussmann GDB1.6: 1.6 Amp Fast Littlefuse 312001: 1.0 Amp Fast

Physical					
Output Torque/Full Travel Stroking Time	Model #	Torque Lb.-ft	N-M	Output Shaft Speed sec/90° @ 60Hz	@ 50Hz
	10261A	10	15	10	12
	10262A	20	27	20	24
	10264A	40	55	40	48
	10266A	60	80	60	72
	10267A	40	55	20	24
	10268A	80	110	40	48
	10269A	150	200	60	72
	10263A	200	270	40	48
10265A	300	400	60	72	
Electrical					
Power Input	120 Vac single phase, 50 or 60 Hz 240 Vac single phase, 50 or 60 Hz				
Motor	Instant start/stop, non-coasting, non-burnout, continuous duty permanent magnet synchronous induction motor. Can be stalled up to 100 hours without damage.				
Motor Current	= No load = full load = locked rotor				
	Model No.	120 V, 50/60 Hz		240 V, 50/60 Hz	
	10261A, 62A, 64A, 66A	0.4 A (48 VA)		0.3 A (24 VA)	
	10263A, 10265A	1.0 A (120 VA)		1.0 A (60 VA)	
	10267A, 68A, 69A	0.8 A (96 VA)		0.3 A (36 VA)	
Loss of Power	Stays in Place				
Local Auto/Manual Switch	Optional - allows local and automatic operation of the actuator.				
Limit Switches	Standard - Two SPDT end of travel limits rated (10 A at 125 Vac, 5 A at 250 Vac).				
Auxiliary Switches	Optional - Up to 4 additional SPDT switches rated (10 A at 125 Vac, 5 A at 250 Vac)				
Certifications					
CE Compliance	89/336/EEC EMC Directive, 73/23/EEC Low Voltage Directive.				
NEMA 4	Optional				
Torque Settings of Crank Arm Bolts					
Clamp Bolt	Standard Arm (p/n 087449) (1-7/16–5 in. adjustment): 85 lb.-ft. Optional Long Arm (p/n 154007) (0–12 in. adjustment): 85 lb.-ft.				
Rod End Bolt	Standard and long arms: 30-35 lb.-ft				

Specification - Actuator with Motor Positioner Board

Electrical		
Input Signals	Input: 4-20 mA 1 to 5 Vdc with appropriate shunt resistor for current range (Resistor: 250 ohms \pm 0.1 % Part No.: 070756)	
Input Impedance	Input 4-20 mA 1-5 V with fail-safe Jumper W2 1-5 V without fail-safe Jumper W2	Input Impedance 250 ohms 10 K ohms 10 M ohms
Sensitivity	0.20 % to 5 % span adjustable (shipped @ 0.5 % span)	
Hysteresis	Less than 0.4 % of full scale	
Linearity	\pm 0.25 % of span	
Repeatability	0.2 % span	
Voltage/ Supply Stability	0.25 % of span with +10/-15 % voltage change	
Temperature Coefficient	Less than \pm 0.030 % of span per degree C for 0 °C to 50 °C Less than \pm 0.05 % of span per degree C for -30 °C to 85 °C	
Zero Suppression	100 % of span	
Input Filter	Adjustable to smooth input signal	
Maximum Input Voltage	5 Vdc	
Output	Two triac switches for raise-or-lower motor operation. Transient voltage protection provided.	
Fail-safe operation	If input signal falls below 2 % of span, there are four choices selected by a movable jumper; stop, go full upscale, go full downscale, or go to a selected (adjustable) position.	
Isolation	Input is isolated from power	

Specification - Actuator with Output Board

Electrical	
Feedback signals	0-20 mA 4-20 mA 1-5 Vdc with 250 ohm resistor $\pm 0.1 \%$ 0-16 Vdc with 800 ohm resistor $\pm 0.1 \%$
Slidewire Emulation	Provides output voltage ratiometric to shaft position and potentiometric to supply voltage (1-20 Vdc) without a slidewire. Emulates a 100 ohms to 1000 ohm slidewire. 10 mA output maximum.
Isolation	Output is isolated from power and input signal by 240 Vac
Load Requirement (4-20)	Current Out — 0-1000 ohms

2.3 Model Selection Guide

Instructions

- Select the desired key number. The arrow to the right marks the selection available.
- Make the desired selections from Tables I thru VII using the column below the arrow.
A dot (•) denotes unrestricted availability.

Key Number I II III IV V VI VII

┌-----┐ - ┌-┐ - ┌-┐ - ┌-┐ - ┌-┐ - ┌-┐ - ┌-┐ - ┌-┐

KEY NUMBER - Electronics			Selection	Availability
Output Torque (lb. - ft.) (N - M)	Full Travel Stroking - Time in Seconds			
	60 Hz	50 Hz		
10 (15)	10	12	10261A	↓
20 (27)	20	24	10262A	↓
40 (55)	40	48	10264A	↓
60 (80)	60	72	10266A	↓
40 (55)	20	24	10267A	↓
80 (110)	40	48	10268A	↓
150 (200)	60	72	10269A	↓
200 (270)	40	48	10263A	↓
300 (400)	60	72	10265A	↓

TABLE I - POWER SUPPLY - SINGLE PHASE

120 VAC 60 Hz	Single Phase 120 VAC 60Hz Motor	1	•
120 VAC 50 Hz	Single Phase 120 VAC 50Hz Motor	2	•
220/240 VAC 60 Hz	Single Phase 220/240 VAC 60Hz Motor	3	•
220/240 VAC 50 Hz	Single Phase 220/240 VAC 50Hz Motor	4	•

TABLE II - CONTROLS

Up/Dn	Drive Up/Dn	0	•
4-20mAdc / 1-5Vdc	4-20mAdc or 1-5Vdc (w/resistor change)	1	•

TABLE III - CUSTOMER POSITION OUTPUTS

None	No position outputs provided	00	•
SEC (Note 1)	One slidewire emulation output (3-Wire Pos. Proportional)	01	•
Analog Output (Note 2)	4-20mAdc, 0-20mAdc, 0-5Vdc, 1-5Vdc, or 0-1.25Vdc	03	•
Film Potentiometer	Dual 1000 ohm	04	d
(Note 3)	Single 1000 ohm	05	e

TABLE IV - CONTACT OUTPUTS

Limit Switches	1 CW & 1 CCW Limit Switch	0	•
Limit/Auxiliary Switches	1CW, 1CCW, & 2 Auxiliary SPDT Switches	2	•
Limit/Auxiliary Switches	1CW, 1CCW, & 4 Auxiliary SPDT Switches	4	•
Limit/Auto-Manual	1CW, 1CCW, Auto/Man Switch	5	•
Limit/Auto/Auxiliary	1CW, 1CCW, Auto/Man Switch & 2 Aux	7	•
Limit/Auto/Auxiliary	1CW, 1CCW, Auto/Man Switch & 4 Aux	9	•

Note 1: Slidewire emulation output is a solid state emulation circuit providing a ratiometric voltage slidewire signal without utilizing an actual slidewire. Emulates slidewires using voltages up to 20.0Vdc.

Note 2: Analog output is factory set to 4-20mAdc. Additional listed outputs are customer selectable by jumper and/or output resistor selection.

Note 3: 135 ohm available with 158 ohm resistor supplied with actuator.
100 ohm available with 110 ohm resistor supplied with actuator.

1A, 2A, 3A, 4A, 5A
6A, 7A, 8A, 9A
1026__

TABLE V - OPTIONS

		Selection	↓
Shafts	Standard	0 ___	•
	5 Inch (127,0 mm) Extension	1 ___	a
	3 Inch (76,2 mm) Extension	3 ___	a
Projecting Scale	None	_ 0 ___	•
	3/4 Inch (19,05 mm) Shaft Coupling, CW	_ 1 ___	b
	3/4 Inch (19,05 mm) Shaft Coupling, CCW to Open	_ 2 ___	b
	1 Inch (25,4 mm) Shaft Coupling, CW	_ 3 ___	b
	1 Inch (25,4 mm) Shaft Coupling, CCW to Open	_ 4 ___	b
	CW to Open, No Coupling	_ 5 ___	c
Crank Arm	5 Inch (127,0 mm) Standard	_ _ 0 _	•
	None	_ _ 1 _	•
	12 Inch (304,8 mm)	_ _ 2 _	•
Rod Adapter	None	_ _ _ 0 _	•
	3/8 Inch (9,53 mm)	_ _ _ 1 _	•
Linkage Kits	None	_ _ _ _ 0	•
	12 In. (30,5 cm) to 16 In. (40,6 cm) Turnbuckle Kit	_ _ _ _ 1	•
	16 In. (40,6 cm) to 20 In. (50,8 cm) Turnbuckle Kit	_ _ _ _ 2	•
	20 In. (50,8 cm) to 24 In. (60,9 cm) Turnbuckle Kit	_ _ _ _ 3	•
	1 Inch (25,4 mm) Pipe Kit	_ _ _ _ 4	•
	1.5 Inch (38,1 mm) Pipe Kit	_ _ _ _ 5	•
	2 Inch (50,8 mm) Pipe Kit	_ _ _ _ 6	•

TABLE VI - OPTIONS

Weatherproof	Weatherproof	0 __	•
	NEMA 4/IP66	1 __	•
Approvals	None	_ 0 _	•
	CE	_ 1 _	•
	CSA	_ 2 _	•
	UL	_ 3 _	•
Tagging	None	_ _ 0	•
	Linen (Note 4)	_ _ 1	•
	Stainless Steel (Note 4)	_ _ 2	•

TABLE VII - OPTIONS 2

Special Manuals	No Special Options (US Manual Standard)	0 _	•
	English (European format)	1 _	•
	French (European format)	2 _	•
Other	None	_ 0	•
	Certificate of Conformance	_ 2	•

ACCESSORIES

	Description	Part Number
Rod Adapters	5/8 Inch (15,88 mm)	083338
	7/16 Inch (11,11 mm)	083336
	7/8 Inch (22,23 mm)	083339
Crank Arm	5 Inch Standard (127,0 mm)	51309967-501
	12 Inch (304,8 mm)	51452160-501

RESTRICTIONS

Restriction Letter	Available Only With		Not Available With	
	Table	Selection	Table	Selection
a	V	XOXXX	Key Number	10263A, 10265A, 10269A
b	V	OX100	Key Number	10263A, 10265A, 10269A
c	V	OXXXX	NA	NA
d	II	0	II	1
e	II	1	II	0

Note 4: Customer must supply tagging information - Up to 3 lines, 22 characters per line.

3. Installation

3.1 Introduction

This chapter provides the user with all the mechanical and electrical information required to get the 10260A Series Actuator up and running in the user's specific application. This chapter also includes safety precautions and unpacking instructions.

3.2 Before Starting

3.2.1 Unpacking

If there are visible signs of damage to the shipping container, notify the carrier and Honeywell immediately.

If there is no visible damage, compare the contents with the packing list. Notify the carrier and Honeywell immediately if there is equipment damage or shortage.

Please do not return goods without contacting Honeywell in advance. The contact number is 1-800-423-9883.

3.2.2 Site Selection

Mount the actuator in a location where it will be easily accessible for maintenance and for manual operation by means of the handwheel. The exact location must be determined in accordance with the linkage used.

It is important that the actuator be mounted securely to a solid foundation commensurate with the maximum torque developed. Use studs or bolts that are as large as the foot mounting holes.

The following precautions should be taken when selecting an installation site.

- Shield the actuator from rain or snow unless the NEMA 4 option was selected.
- Allocate sufficient space around the actuator for the removal of all covers to permit inspection or calibration and to provide access to the handwheel.
- Use auxiliary shielding to protect the actuator from excessive heat or cold outside of the rating of the Actuator and from corrosive elements
- Ambient temperature should not exceed 185 °F (85 °C).
- The minimum low temperature limit is -20 °F (-30 °C).

3.2.3 Outline Dimension Drawings

An outline and dimension drawing for mounting is furnished with each unit. See also Figure 3-1 and Figure 3-2.

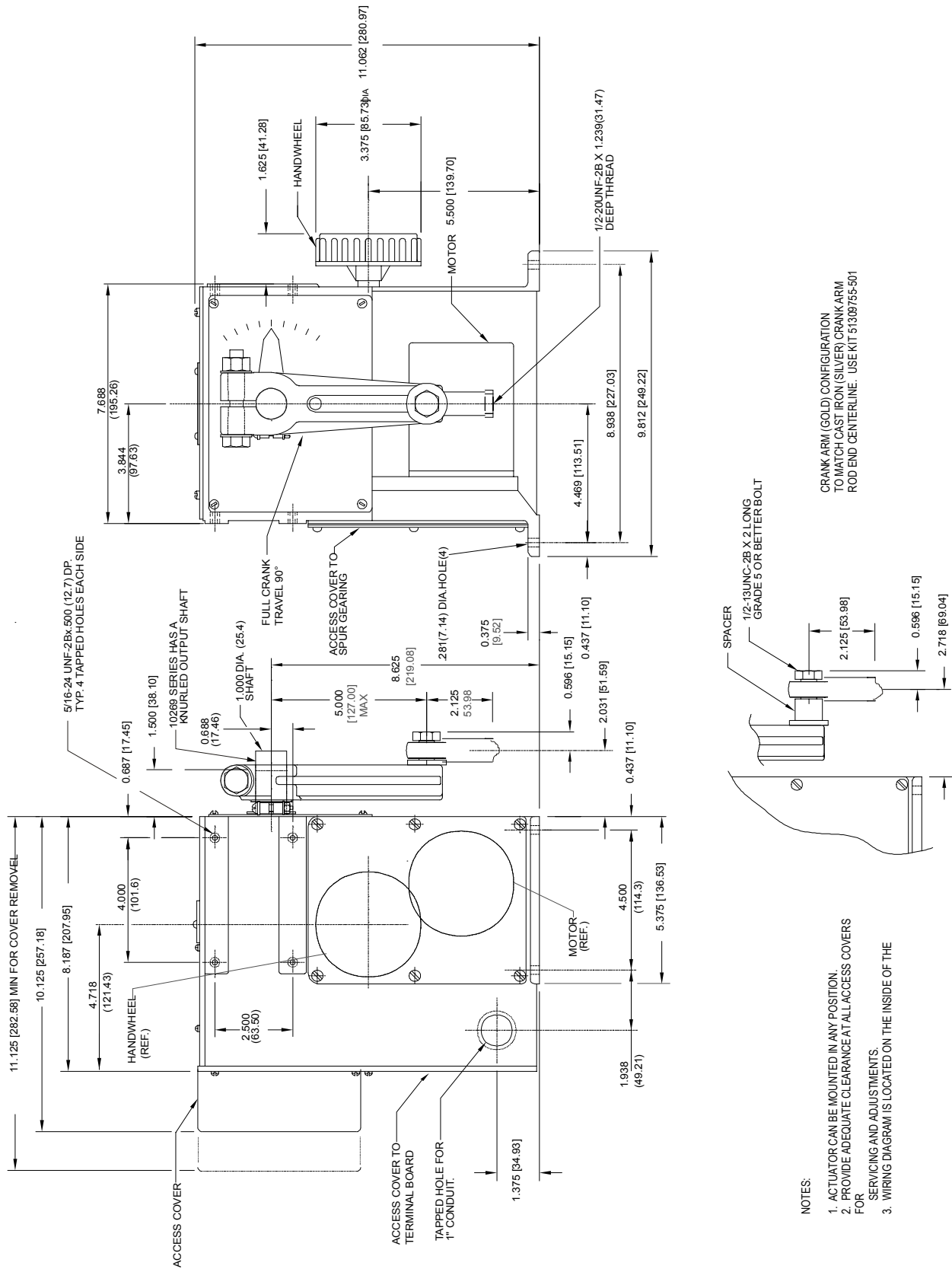

Figure 3-1 Outline and Dimensions of 10261A, -62A, -64A, -66A, -67A, -68A, and -69A Actuators

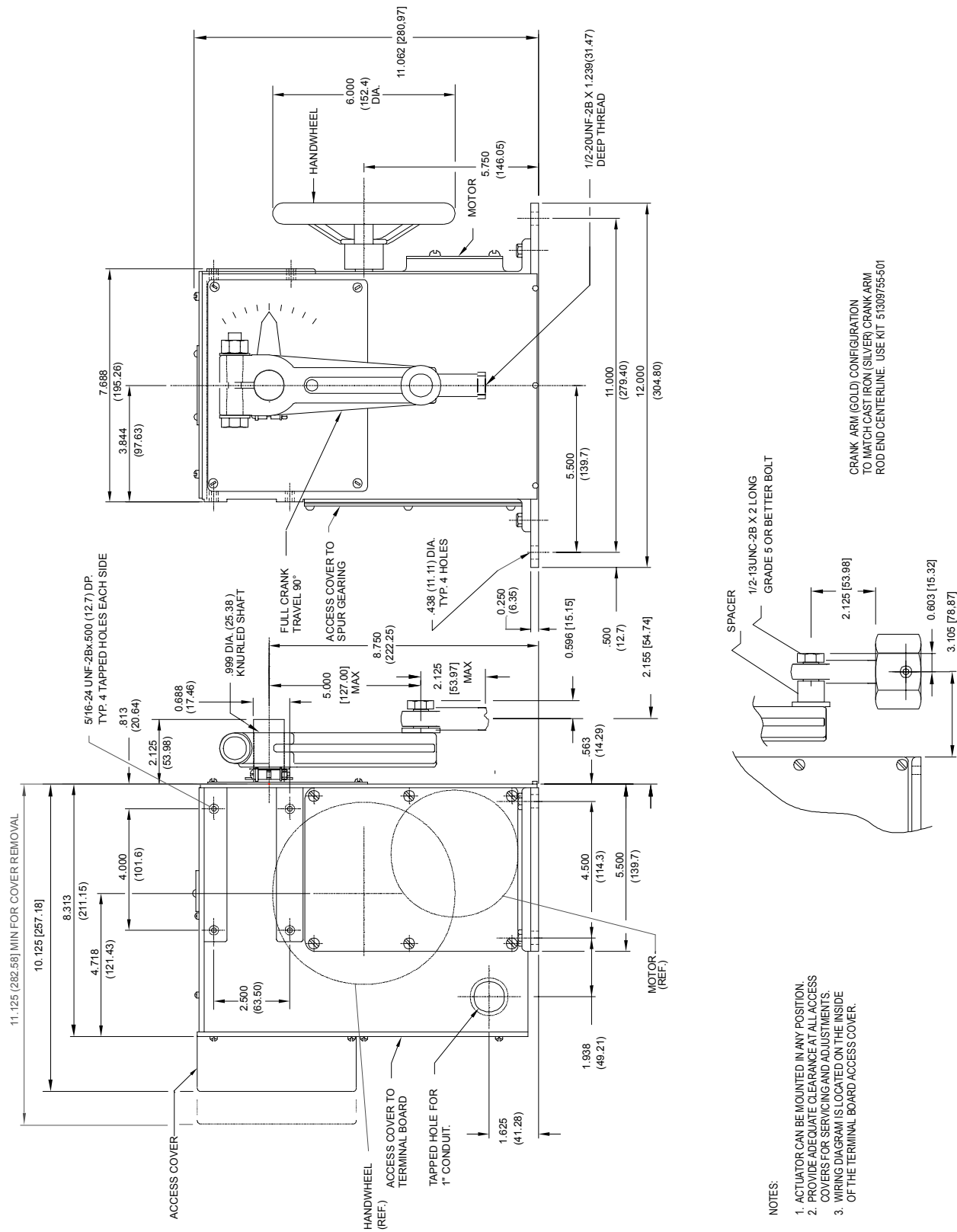

Figure 3-2 Outline and dimensions of 10263A and 10265A Actuators

3.3 Mechanical Installation

3.3.1 General

Install the 10260A series actuator in a convenient location in any orientation. Firmly bolt the 10260A to a mounting surface that will not distort when subjected to the torque stresses generated by the actuator. The output shaft of the actuator should be parallel to the output shaft of the driven device. The output shaft crank arm is fully adjustable through 360°.

3.3.2 Linkage Set-up

General

Many applications require the use of a linkage assembly and often the final control element does not have a linear torque curve. The 10260A Series Actuator linkage can be set up to achieve an optimal delivered torque distribution for specific applications. To assist with linkage design, Honeywell offers a linkage analysis software package (HAL). The software can be ordered as P/N 51197910-001.

Constant Torque Linkage

A constant torque linkage is employed when it is desired to provide a linear torque profile throughout the full range of final control element travel. In this situation, the actuator and driven crank arms will be set-up proportionally with respect to each other. Figure 3-3 shows a general linkage setup to achieve a linear torque profile and Figure 3-4 shows the resultant profile.

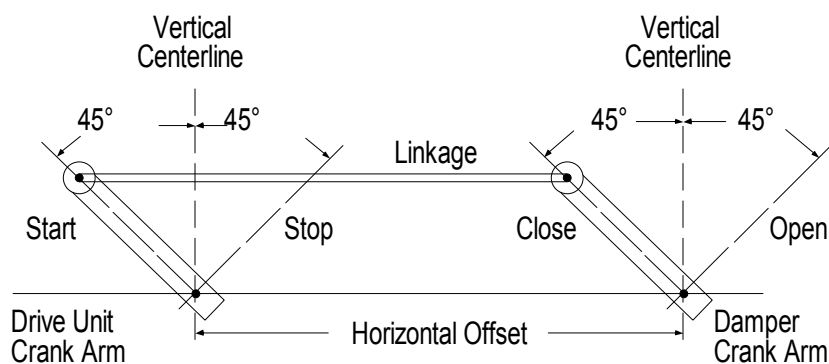

a/n 23199

Figure 3-3 Constant Torque Linkage

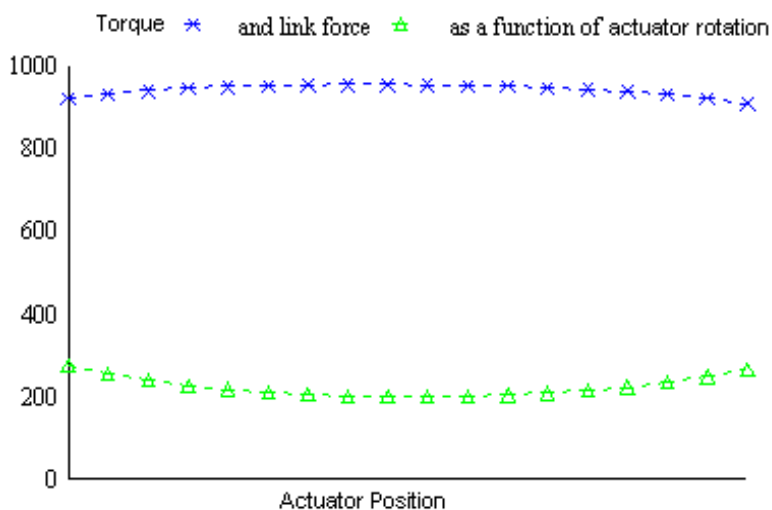

Figure 3-4 Constant Torque Profile

Variable Torque Linkage

A variable torque linkage is employed when it is desired to provide a non-linear torque profile throughout the full range of final control element travel. In this general situation, the actuator and driven crank arms will be set up to provide a higher torque for seating or unseating the final control element. Figure 3-5 shows a general linkage setup to achieve a non-linear torque profile and Figure 3-6 shows the resultant profile. Note that this linkage can be characterized in many different ways by varying start angles and rotation requirements of both the Actuator Crank Arm and the Driven Arm.

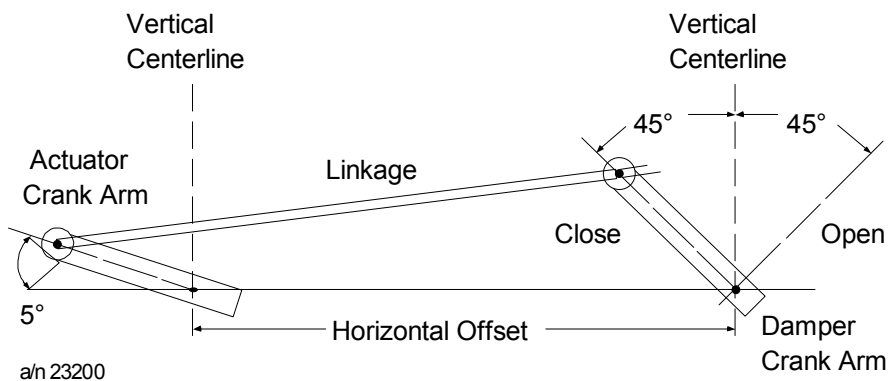

Figure 3-5 Variable Torque Linkage

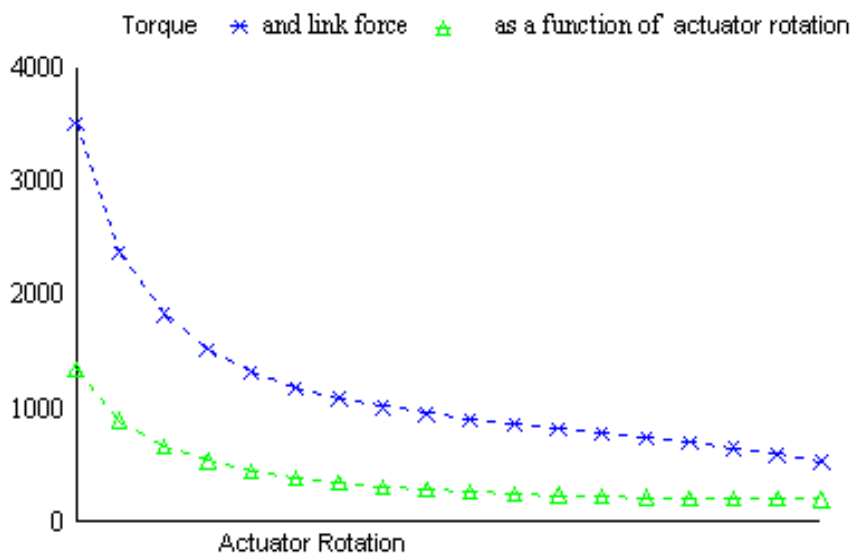

Figure 3-6 Variable Torque Profile

Turnbuckle Linkage Kits

(See Section 8 for Kit numbers.)

These kits are to be used where short lengths are required. These lengths range from 12 to 24 inches and refer to the rod end center - to - center distance. All turnbuckle kits include the turnbuckle, load rod end (left-hand thread), connecting rods and locking nuts. The nut and bolt needed to connect the rod end to the load are supplied by the Customer. The actuator rod end (right-hand thread), nut and bolt are supplied with the actuator. These kits can be ordered with the Actuator via Table VI of the Model Selection Guide or separately as identified in section 8.4 of this manual.

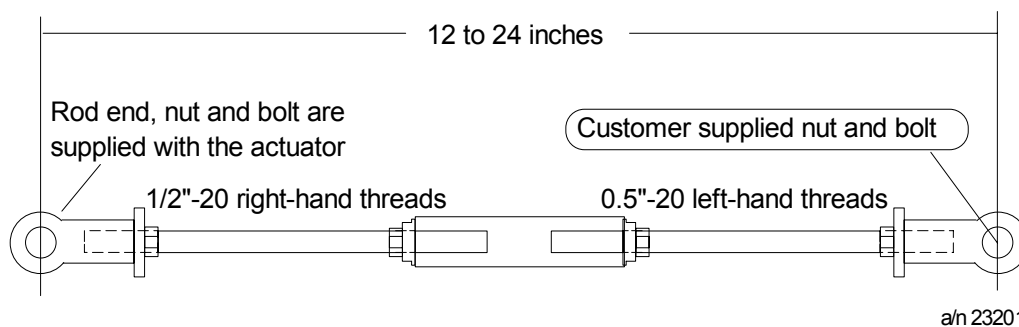

Figure 3-7 Turnbuckle Linkage Kit

Pipe Linkage Kits

(See Section 8 for Kit numbers.)

These kits are used for linkage lengths from 24 inches to 120 inches (60 cm to 305 cm). All pipe linkage kits include the mechanical pipe couplings, load rod end (left-hand thread), connecting rods and locking nuts. The Customer must supply a piece of schedule 40 pipe * (both ends with right-hand NP threads) and a nut and bolt to connect the rod end to the load. The actuator rod end (right-hand thread), nut and bolt are supplied with the actuator. These kits can be ordered with the Actuator using Table VI of the Model Selection Guide or separately as identified in Section 8, Replacement/Recommended Spare Parts of this manual.

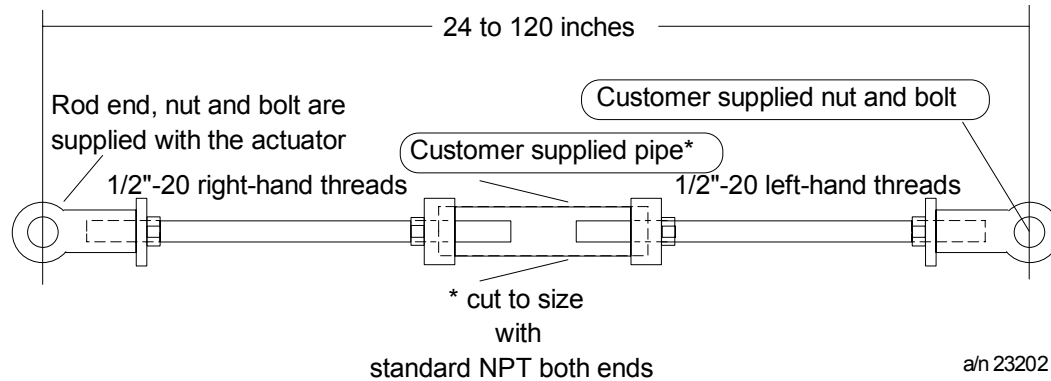

Figure 3-8 Pipe Linkage Kit

*Pipe length = Overall linkage length minus (-) 17 inches (43 cm).

Actuator Crank Arms

The 10260A Series Actuator comes standard with a 5” crank arm (p/n 51309967-501) or an optional crank arm adjustable 0”-12” (p/n 51452160-501).

The 10260A Series Actuator crank arm uses a standard 1/2” rod end to compliment the turnbuckle and pipe linkage kits. The crank arm connects the link rod using a 1/2” rod end and a hex link rod adapter. For applications which use a link rod, a link rod adapter is available as an option in the Model Selection Guide.

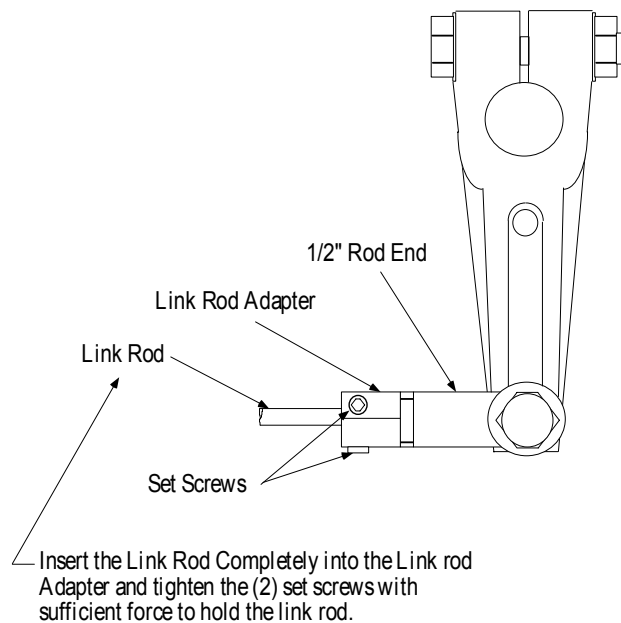

Figure 3-9 Standard 5” Crank Arm

3.3.3 Projecting Scale Option

The projecting scale option is available for customers whose actuators are direct coupled that it would be impossible to read the standard scale on the actuator. The projecting scale sits above the actuator and is readable from a distance. See Figure 3-10 Projecting Scale Option.

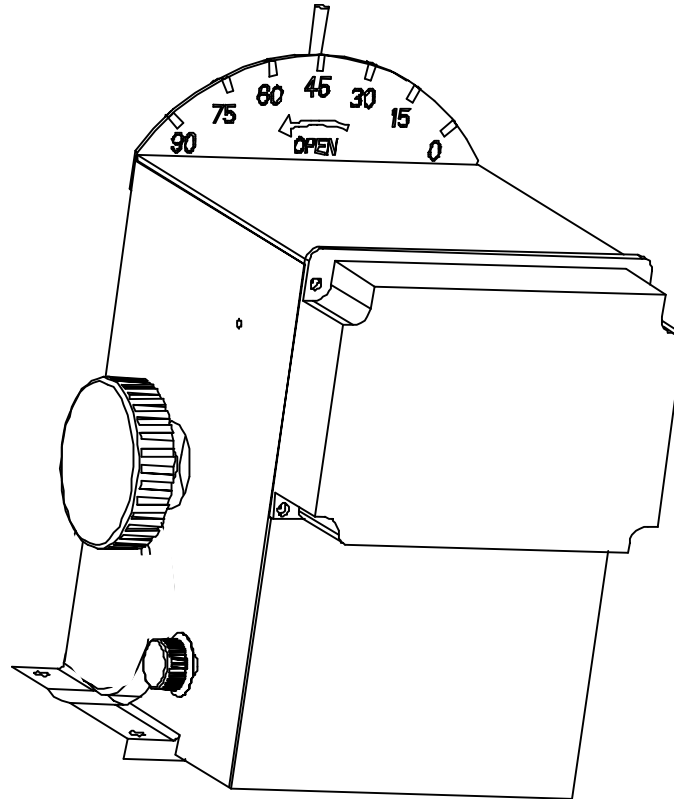

Figure 3-10 Projecting Scale Option

3.4 Electrical Installation

3.4.1 General Wiring Recommendations



WARNING

Wiring should be performed by qualified personnel only.
Wiring must conform to national and local electrical codes.

In general, stranded copper wire should be used. Unless locally applicable codes dictate otherwise, the recommended minimum wire sizes in Table 3-1 should be observed.

Table 3-1 Recommended Minimum Wire Size

Gage No.	Description
14	Earth ground wire to common power supply.
18	Earth ground wire to single actuator. 120/240 V ac line leads. +24 V and common signal leads.

Safety Precautions



WARNING

An external disconnect switch must be installed to break all current carrying conductors. Turn off power before working on conductors. Failure to observe this precaution may result in serious personal injury.

3.4.2 Customer Connections



WARNING



The ground terminal must be connected to a reliable earth ground.



WARNING

While the unit is powered, a potentially lethal shock hazard exists inside the case. Do not open the case while the unit is powered. Do not access the terminals while the unit is powered.

Figure 3-11 and Figure 3-12 show all the available connections for the 10260A Series actuator (non-contact sensor).

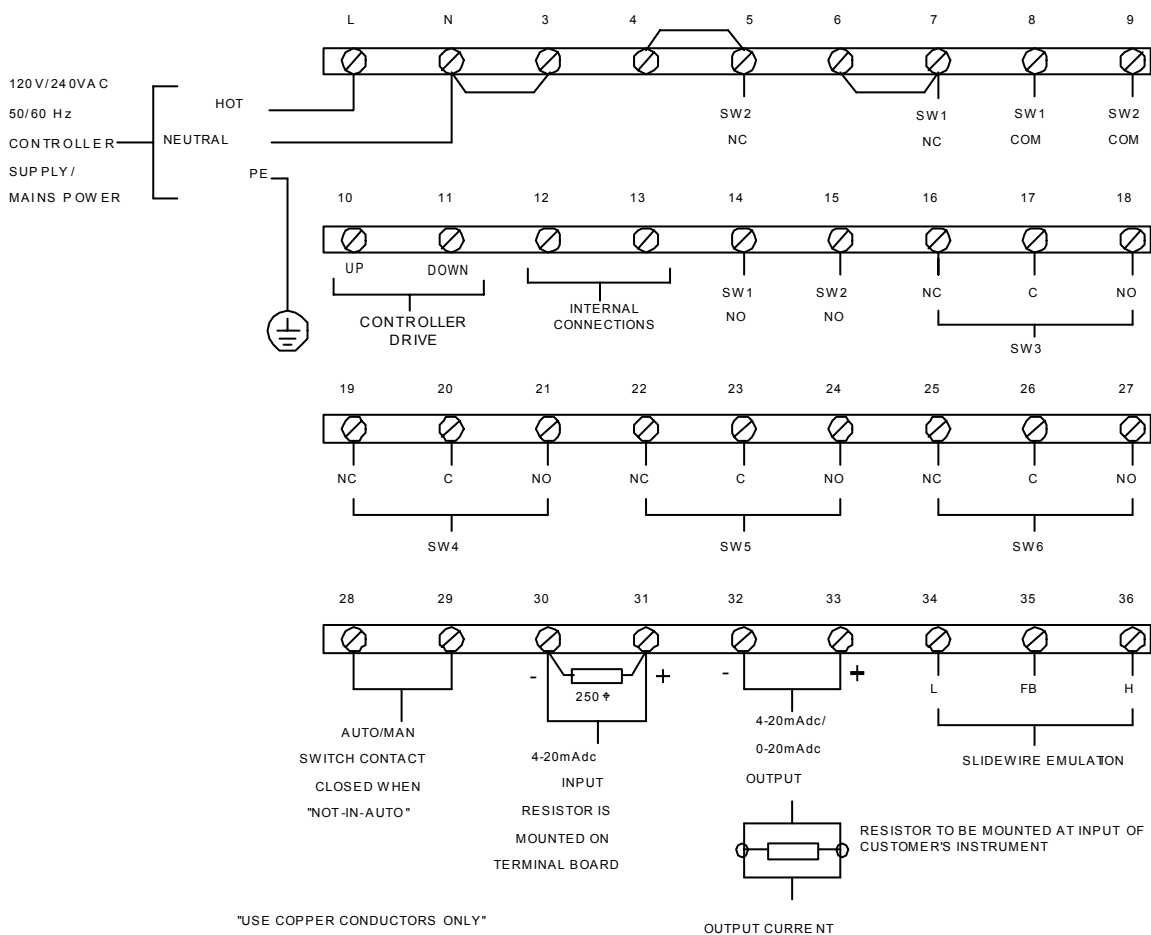
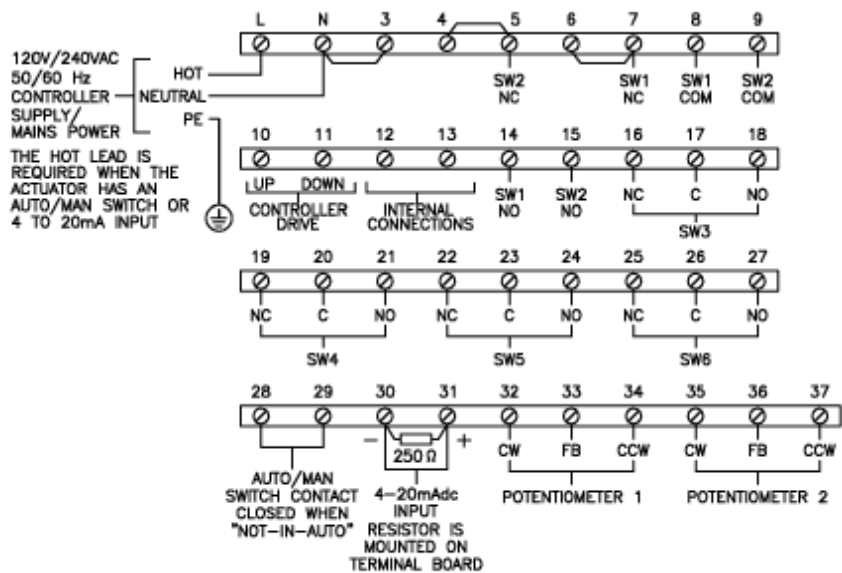

Figure 3-11 Customer Terminal Connections (Non-contact sensor)



USE COPPER CONDUCTORS ONLY

Figure 3-12 Customer Terminal Connections (Film Potentiometer)

3.4.3 Power Connections

For connections, refer to section 3.4.2. Customer Connections.

3.4.4 CE Wiring

For CE approved units clamp the ferrite filter provided (087414) around the AC mains power supply wires (hot, neutral, ground) inside the case near the conduit entry.

3.4.5 0/4-20 mA, 0/1-5 Vdc Input Signal Connections

For connections, refer to section 3.4.2. Customer Connections.

ATTENTION

Shielded and grounded cables are recommended.

3.4.6 0/4-20 mA, 0/1-5 Vdc Feedback Signal Connections

For connections, refer to section 3.4.2. Customer Connections.

ATTENTION

Shielded and grounded cables are recommended.

3.4.7 Slidewire Emulator Connections

For connections, refer to Figure 3-11 and Figure 3-13.

ATTENTION

Shielded and grounded cables are recommended.

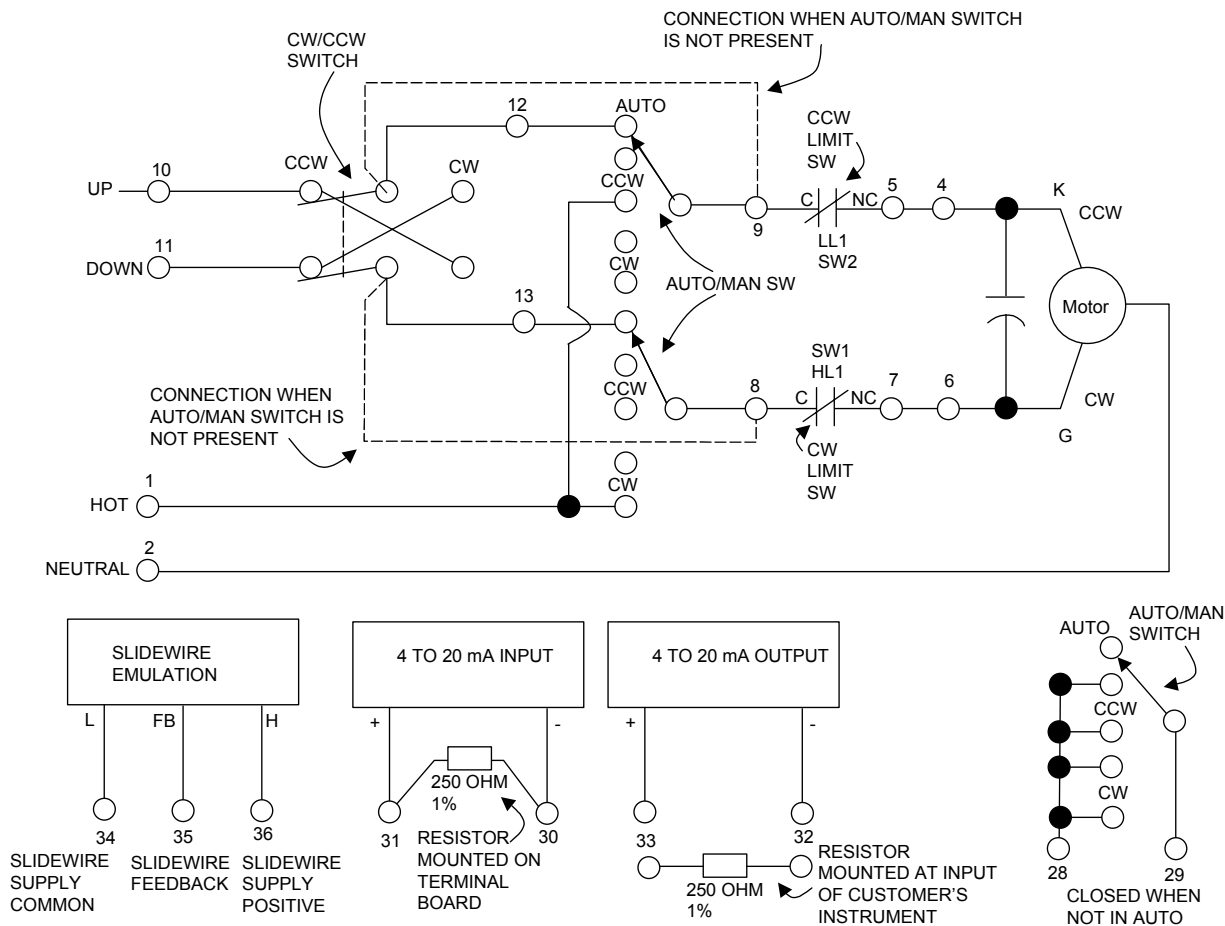

Figure 3-13 Slidewire Connections

4. Calibration Procedures

4.1 Overview

Calibration of the 10260A Series Actuator may consist of setting the limit and auxiliary switches, calibrating the non-contact sensor, calibrating the motor position board that positions the actuator with 0/4-20mA input signal, and calibrating the slidewire emulation output or the 0/4-20mA output signal.

In calibrating the non-contact position sensor assembly, it is necessary to determine whether the actuator actuation is rotating in a clockwise or counterclockwise direction with increasing control signal. Clockwise and counterclockwise rotation is the direction of the output shaft when facing the end of the shaft and refers to the direction of rotation on increasing signal. All actuators are shipped in a default configuration for counterclockwise operation. Counterclockwise operation moves the shaft (and the pointer on the left-hand scale) in a counterclockwise direction on increasing signal and clockwise on decreasing signal. Simply changing the toggle switch position on the terminal plate and a jumper on the output board (NCS) or interchanging potentiometer leads at the terminal board (film potentiometer) (see section 4.7) will change the actuator from counterclockwise operation to clockwise operation.

WARNING

Calibration should be performed by qualified personnel only.

4.2 Setting End-of-Travel Limit Switches (actuators mfd. pre-1/1/03)

WARNING

While the unit is powered, a potentially lethal shock hazard exists inside the case.

ATTENTION

The first two cams (starting from the back) are for the 0 % and 100 % limit switches and should not need any adjustments as they are factory set to stop the drive at 0 % and 100 %.

To adjust the limit switch cams (See Figure 4-2):

1. Remove the cover. (Non-contact sensor and terminal cover, see Figure 1-1.)
2. Turn the locking nut, found behind the sensor, counter-clockwise using a 1/8" allen wrench or the equivalent inserted into the radial holes in the locking nut until it is possible to turn the cams with your fingers.
3. Using a slotted screwdriver on the slots at the edge of the cams, or your finger, rotate the cams until the switches are set. (See Figure 4-1.)
 - Rotate the actuator shaft, using the manual handwheel or the auto/manual switch, to the 0 % position (this is the 0 % for CCW operation using the left-hand scale or 100 % for CW operation using the right hand scale). If the actuator is installed on a damper or valve, also make sure that this position is synchronized with the travel of the final control element.
 - Rotate the #1 limit switch operating cam to activate at this position. The switch roller arm should go from being in an up, not depressed state, to a depressed state as the cam is rotated in the direction of the shaft rotation going toward the limit position. This will cause the switch to go from NC to NO and turn off the power to the motor when the switch activates. Switch activation

may be detected by the clicking sound or with a continuity tester connected to the terminals. Both the NC and NO contact states are available to the customer at the terminals (see Figure 3-11).

- Rotate the actuator shaft, using the manual handwheel or the auto/manual switch, to the 100 % position (this is 100 % for CCW operation using the left-hand scale or 0 % for CW operation using the right hand scale). If the actuator is installed on a damper or valve, also make sure that this position is synchronized with the travel of the final control element.
 - Rotate the #2 limit switch operating cam to activate at this position. The switch roller arm should go from being in an up, not depressed state, to a depressed state as the cam is rotated in the direction of the shaft rotation going toward the limit position. This will cause the switch to go from NC to NO and turn off the power to the motor when the switch activates. Both the NC and NO contact states are available to the customer at the terminals (see Figure 3-11).
 - If optional auxiliary switches were ordered, these switches may also be set at this time. (See Section 4.4 for details of setting auxiliary switches.)
4. Once the cams are set in the correct positions, turn the locking nut clockwise until snug tight (it does not have to be “hard” tight and does not have to completely flatten the spring washer).
 5. Double check limit switch actuation by first manually driving the actuator to each end of travel and hearing the switch click or by detecting it with a continuity tester. Secondly, drive the actuator to both ends of travel (using the auto/manual switch or by providing minimum and full input signal) and make sure the switches activate and turn off the motor.

ATTENTION

Make sure not to set the switch too close to the hard stop.

REFERENCE

An unactuated switch will have its normally closed (NC) contacts closed and its normally open (NO) contacts open.

An actuated switch will have its NC contacts become open and its NO contacts become closed. Both NC and NO contacts are available to the customer on the terminal board (Figure 3-11).

An unactuated switch has its roller arm in the up position when adjacent to the reduced diameter portion of the cam.

4.3 Setting End-of-Travel Limit Switches (actuators mfd. after 1/1/03)

WARNING

While the unit is powered, a potentially lethal shock hazard exists inside the case.

ATTENTION

The first two cams (starting from the back) are for the 0 % and 100 % limit switches and should not need any adjustments as they are factory set to stop the drive at 0 % and 100 %.

To adjust the limit switch cams (see Figure 4-1):

1. Remove the cover (terminal cover, see Figure 1-1).
2. Using a slotted screwdriver on the slots at the edge of the cams, or your finger, rotate the cams until the switches are set (see Figure 4-1).
 - Rotate the actuator shaft, using the manual handwheel or the auto/manual switch, to the 0 % position (this is the 0 % for CCW operation using the left-hand scale or 100 % for CW operation using the right hand scale). If the actuator is installed on a damper or valve, also make sure that this position is synchronized with the travel of the final control element.
 - Rotate the #1 limit switch operating cam to activate at this position. The switch roller arm should go from being in an up, not depressed state, to a depressed state as the cam is rotated in the direction of the shaft rotation going toward the limit position. This will cause the switch to go from NC to NO and turn off the power to the motor when the switch activates. Switch activation may be detected by the clicking sound or with a continuity tester connected to the terminals. Both the NC and NO contact states are available to the customer at the terminals (see Figure 3-11).
 - Rotate the actuator shaft, using the manual handwheel or the auto/manual switch, to the 100 % position (this is 100 % for CCW operation using the left-hand scale or 0 % for CW operation using the right hand scale). If the actuator is installed on a damper or valve, also make sure that this position is synchronized with the travel of the final control element.
 - Rotate the #2 limit switch operating cam to activate at this position. The switch roller arm should go from being in an up, not depressed state, to a depressed state as the cam is rotated in the direction of the shaft rotation going toward the limit position. This will cause the switch to go from NC to NO and turn off the power to the motor when the switch activates. Both the NC and NO contact states are available to the customer at the terminals (see Figure 3-11).
 - If optional auxiliary switches were ordered, these switches may also be set at this time. (See Section 4.5 for details of setting auxiliary switches.)
3. No additional adjustments are required.
4. Double check limit switch actuation by first manually driving the actuator to each end of travel and hearing the switch click or by detecting it with a continuity tester. Secondly, drive the actuator to both ends of travel (using the auto/manual switch or by providing minimum and full input signal) and make sure the switches activate and turn off the motor.

4.4 Setting Auxiliary Switches (actuators mfd. pre-1/1/03)

WARNING

While the unit is powered, a potentially lethal shock hazard exists inside the case.

ATTENTION

The first two cams (starting from the back) are for the 0 % and 100 % end of travel limit switches and should not need any adjustments as they are factory set to stop the actuator at 0 % and 100 %. See Section 4.2 for setting end of travel limit switches (Switches #1 and #2)

If optional auxiliary switches were ordered, these switches are factory set to 10 % and 90 % for switches #3 and #4 and to 20 % and 80 % for switches #5 and #6. Additional switch settings should be set so that switch #3 operates in synchronism with switch #1 (i.e., both activating when the actuator is going in the same direction) and switch #4 to operate in synchronism with switch #2, etc.

To adjust the next auxiliary switch cams (see Figure 4-3):

1. Remove the cover. (Non-contact sensor and terminal cover, see Figure 1-1.)
2. Turn the locking nut, found behind the sensor, counter-clockwise using a 1/8" allen wrench or equivalent inserted into the radial holes in the locking nut until it is possible to turn the cams with your fingers.
3. Using a slotted screwdriver on the slots on edge of cams, or your fingers, rotate the cams until the switches are set. (See Figure 4-1.)
 - The auxiliary switches should be set so switches #3 and #5 operate in synchronism with switch #1 (i.e., both activating when the drive is going in the same direction) and set switches #4 and #6 to operate in synchronism with switch #2.

For Switches #3 and #5:

- Rotate the actuator shaft, using the manual handwheel or the auto/manual switch, to the desired low scale position.
- Rotate the #3 switch operating cam to activate at this position. The switch roller arm should go from being in an up, not depressed state, to a depressed state as the cam is rotated in the direction of the shaft rotation going toward the limit position. This will cause the switch to go from NC to NO when the switch activates. Switch activation may be detected by the clicking sound or with a continuity tester connected to the terminals. Both the NC and NO contact states are available to the customer at the terminals (see Figure 3-11).
- Repeat for Switch #5 if applicable.

For Switches #4 and #6:

- Rotate the actuator shaft, using the manual handwheel or the auto/manual switch, to the desired up scale position.
- Rotate the #4 switch operating cam to activate at this position. The switch roller arm should go from being in an up, not depressed state, to a depressed state as the cam is rotated in the direction of the shaft rotation going toward the limit position. This will cause the switch to go from NC to NO when the switch activates. Both the NC and NO contact states are available to the customer at the terminals (see Figure 3-11).
- Repeat for Switch #6 if applicable.

4. Once the cams are set in the correct positions, turn the locking nut clockwise until snug tight (it does not have to be “hard” tight and does not have to completely flatten the spring washer).
5. Double check limit switch actuation by first manually driving the actuator to each end of travel and hearing the switch click or by detecting it with a continuity tester. Secondly, drive the actuator to both ends of travel (using the auto/manual switch or by providing minimum and full input signal) and make sure the switches activate.

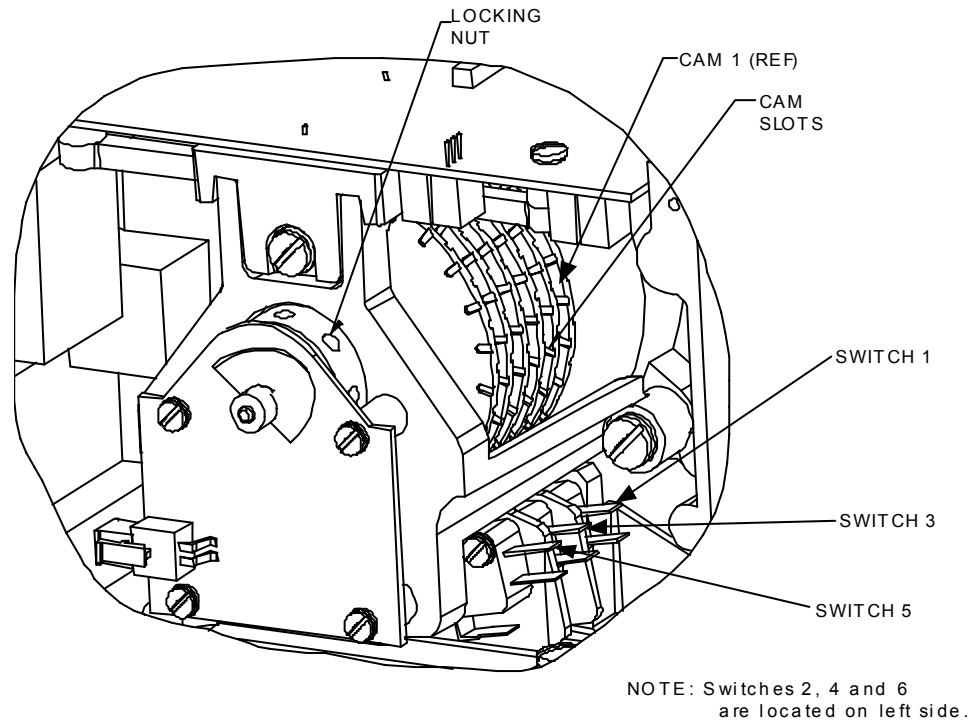
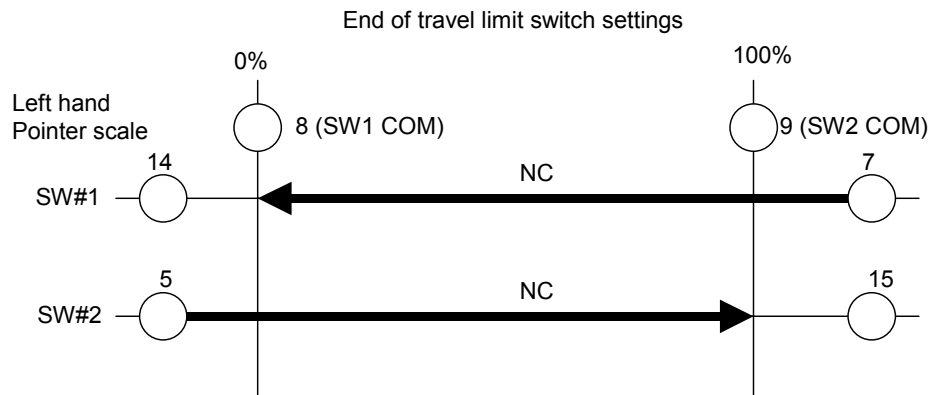

Figure 4-1 Location of Auxiliary Switches



Clockwise and counterclockwise rotation is the direction of the output shaft when facing the end of the shaft. As shown, clockwise rotation of the output shaft activates SW#1 (at 0% on left hand pointer scale) and CCW rotation activates SW#2 (at 100% on left hand pointer scale). Terminal numbers are next to circles (see Figure 3-11).

Figure 4-2 End of Travel Limit Switch Settings

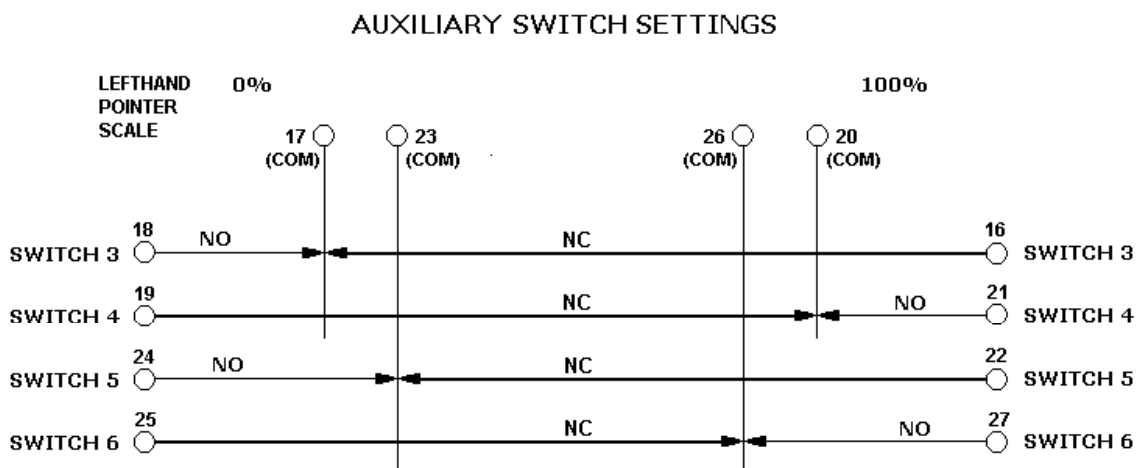

Figure 4-3 Auxiliary Switch Settings

4.5 Setting Auxiliary Switches (actuators mfd. after 1/1/03)

WARNING

While the unit is powered, a potentially lethal shock hazard exists inside the case.

ATTENTION

The first two cams (starting from the back) are for the 0 % and 100 % end of travel limit switches and should not need any adjustments as they are factory set to stop the actuator at 0 % and 100%. See Section 4.3 for setting end of travel limit switches (Switches #1 and #2).

If optional auxiliary switches were ordered, these switches are not set by the factory. Switch settings should be set so that switch #3 operates in synchronism with switch #1 (i.e., both activating when the actuator is going in the same direction) and switch #4 to operate in synchronism with switch #2, etc.

To adjust the next auxiliary switch cams (see Figure 4-3):

1. Remove the terminal cover (Figure 1-1).
2. Using a slotted screwdriver on the slots at the edge of the cams, or your finger, rotate the cams until the switches are set (see Figure 4-1).
3. The auxiliary switches should be set so switches #3 and #5 operate in synchronism with switch #1 (i.e., both activating when the drive is going in the same direction) and set switches #4 and #6 to operate in synchronism with switch #2.

For Switches #3 and #5:

4. Rotate the actuator shaft, using the manual handwheel or the auto/manual switch, to the desired low scale position.
5. Rotate the #3 switch operating cam to activate at this position. The switch roller arm should go from being in an up, not depressed state, to a depressed state as the cam is rotated in the direction of the shaft rotation going toward the limit position. This will cause the switch to go from NC to NO when the switch activates. Switch activation may be detected by the clicking sound or with a continuity tester connected to the terminals. Both the NC and NO contact states are available to the customer at the terminals (see Figure 3-11).

For Switches #4 and #6:

6. Rotate the actuator shaft, using the manual handwheel or the auto/manual switch, to the desired up scale position.
7. Rotate the #4 switch operating cam to activate at this position. The switch roller arm should go from being in an up, not depressed state, to a depressed state as the cam is rotated in the direction of the shaft rotation going toward the limit position. This will cause the switch to go from NC to NO when the switch activates. Both the NC and NO contact states are available to the customer at the terminals (see Figure 3-11).
8. No additional adjustments are required.
9. Double check limit switch actuation by first manually driving the actuator to each end of travel and hearing the switch click or by detecting it with a continuity tester. Secondly, drive the actuator to both ends of travel (using the auto/manual switch or by providing minimum and full input signal) and make sure the switches activate.

Clockwise and counterclockwise rotation is the direction of the output shaft when facing the end of the shaft. As shown, clockwise rotation of the output shaft activates Switch 3 and Switch 5 similar to Limit Switch 1. Counterclockwise rotation of the output shaft activates Switch 4 and Switch 6 similar to Limit Switch 2.

Terminal numbers are next to circles (see Figure 3-11).

4.6 Non-Contact Sensor

WARNING

While the unit is powered, a potentially lethal shock hazard exists inside the case.

ATTENTION

The 10260A Series Actuator comes with the Non-Contact Position Sensor (NCS) already adjusted from the factory to 90 degree rotation.

If it becomes necessary to do an adjustment in the field, use the procedure given below.

1. Loosen the allen screw in the hub of the NCS spoiler just enough to be able to rotate the spoiler. (See Figure 4-4.)
2. Drive the actuator to the zero position (this refers to the position on the actuator scale for CCW rotation). This should be done manually with the hand wheel or manually with the auto/man electric switch. Next, rotate the NCS spoiler to its 0° position (it is shown in Figure 4-4 at a 45 degree angle or 10:00 o'clock zero position for CCW operating units). For CW operating units, the actuator is positioned at its 100 % position and the NCS spoiler is again at a 45 degree angle or 10:00 o'clock position. Tighten NCS spoiler set screw with allen wrench, holding spoilers in position. Spoilers need to be held in position both rotationally and longitudinally along the drive shaft extension (the gaps between each of the spoilers and the sensor circuit board should be approximately equal and any plastic or paper insulating material may be used to aid in this longitudinal positioning). Make sure that neither spoiler is touching the sensor electronics board when the adjustment is complete.
3. Connect the lead wires of a precision digital voltmeter to connector W11 pins on the 4-20 mA output card on the actuator. (The output board is positioned over the control shaft and the W11 connector is on the underside of the board just to the right of the center mounting screw). Connect the positive lead (+) to the W11 pin #2 and the negative lead (-) to pin #1.
4. Read the voltage. Voltage should be between 0.01 V and 0.02 V if the spoiler is positioned correctly.
5. If voltage is not correct, re-position the spoiler and take another voltage reading.
6. Once the voltage is within the correct range, the spoiler is in the 0° position.
7. Tighten the spoiler set screw with allen wrench.

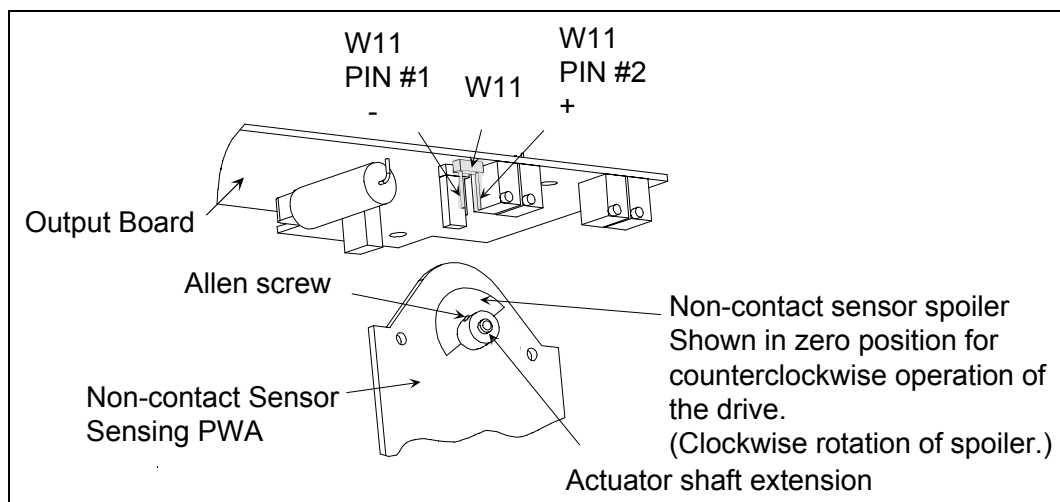

Figure 4-4 Location of NCS Assembly

4.7 Motor Positioner Board

WARNING

While the unit is powered, a potentially lethal shock hazard exists inside the case.

ATTENTION

The Motor Positioner board is mounted inside the top extended cover. The cover with the Motor Positioner board and cables still connecting it to the NCS Sensor and NCS board may be unscrewed from the actuator housing and positioned nearby with cables connected to make adjustments.

The Motor Positioner board has been factory calibrated for 0 % and 100 % SPAN positioning. It has also been set for default conditions given in Table 4-1.

4.7.1 Overview

The Motor Positioner board provides accurate feedback control of the actuator position proportional to a 0/4 – 20 mA input signal. It also provides selectable failsafe action, input filtering and deadband sensitivity adjustment.

If the Motor Positioner option has been purchased by the user, its' calibration is factory set, but may be adjusted as a part of the 10260A Series Actuator preliminary adjustment sequence. Once all adjustments have been made, the Motor Positioner will be fully operational.

4.7.2 Available Adjustments

Operating adjustments are located on the printed circuit board accessed by removing the non-contact sensor and terminal cover. Altogether, there are two jumpers and five potentiometers with the following designations and functions:

Table 4-1 Available Adjustments

Adjustment	Marking	Function
Jumper	W1	Selects fail-safe actuator position. Selects full up or full down. Remove W1 to disable fail-safe feature. Default is "UP" position.
Jumper	W2	Selects fail-safe actuator position if input signal is lost. Selects stop, or a particular position determined by R14. Remove W2 to disable fail-safe feature Default is STOP.
Potentiometer	Filter, R1	Input signal filter adjustment. Default is MINIMUM.
Potentiometer	Span, R7	Input signal span adjustment.
Potentiometer	Zero, R11	Input signal zero adjustment.
Potentiometer	Failsafe Set, R14	Adjust fail-safe position of actuator on loss of input signal. Must be enabled by W2.
Potentiometer	D.U.Sens., R19	Adjusts actuator motor deadband from 1 % to 5 %. Default is ½ turn OFF maximum sensitivity. (This is ½ turn off of full CCW.)

4.7.3 ZERO and SPAN Adjustments

WARNING

While the unit is powered, a potentially lethal shock hazard exists inside the case. Do not open the case while the unit is powered. Disconnect power before moving jumpers.

REFERENCE

Note that jumpers (W1 and W2) may be inserted to connect the common (center) terminal to either of two other terminals. Pull the jumper straight out from the board surfaces to remove it. To install it, align it with the desired pair of terminals and push it firmly into place.

To set the Zero and Span adjustments, use the following procedure:

1. Disconnect power.
2. Remove jumper W2 from the circuit board and set it aside for later replacement. (See Figure 4-5.)
3. Verify that limit switches and the actuator travel relative to the mechanical stops are correctly adjusted. (See Section 4.2.)
4. Make sure actuator is in CCW mode. (See Section 4.9, Step 1 only, to reverse direction.)
5. Apply power and set the input to minimum value (4 mA for 4-20 mA input, for example).
6. Adjust ZERO potentiometer (R11) until the actuator is at the desired “down” position. Pointer should point to 0 % on CCW (left) scale or 100 % on CW (right) scale.
7. Set the input to maximum value (20 mA for 4-20 mA input).
8. Adjust SPAN potentiometer (R7) until the actuator is at the desired “up” position. Pointer should point to 100 % on the CCW (left) scale or 0 % on CW (right) scale.
9. Set the input to minimum again and readjust the ZERO setting, if necessary. Repeat steps 6 through 8 until ZERO and SPAN positions are correct.
10. Disconnect power and replace jumper W2 in the desired position (refer to “Fail-safe Adjustments” in this chapter for instructions for installing W2). If CW operation is desired, reverse direction (see Section 4.9).

4.7.4 Fail-Safe Settings; Loss of Signal (L.O.S.)



WARNING

While the unit is powered, a potentially lethal shock hazard exists inside the case. Do not open the case while the unit is powered. Disconnect power before moving jumpers.

REFERENCE

Note that jumpers (W1 and W2) may be inserted to connect the common (center) terminal to either of two other terminals. Pull the jumper straight out from the board surfaces to remove it. To install it, align it with the desired pair of terminals and push it firmly into place.

Select the fail-safe setting for the event of a loss of input signal (signal from the controller to the Motor Positioner). There are two fail-safe choices, selectable by jumper W2: stop the actuator immediately, or bring the actuator to a stop at some particular position.

1. To cause the actuator to stop immediately if input signal is lost, install W2 so that it connects the center and “STOP” terminals.
2. To cause the actuator to move to a particular position if input signal is lost, place W2 so that it connects the center and “SET POS,” terminals. Then select the particular positioner that you want, as follows (you may select fully up, fully down, or any point in between).
3. With the W2 jumper installed in “SET POS” position, apply power and interrupt the input signal. The actuator will move to some random position and stop.
4. Adjust FAILSAFE SET potentiometer (R14) until the actuator is positioned at the desired fail-safe point.

To disable this fail-safe feature, remove W2.

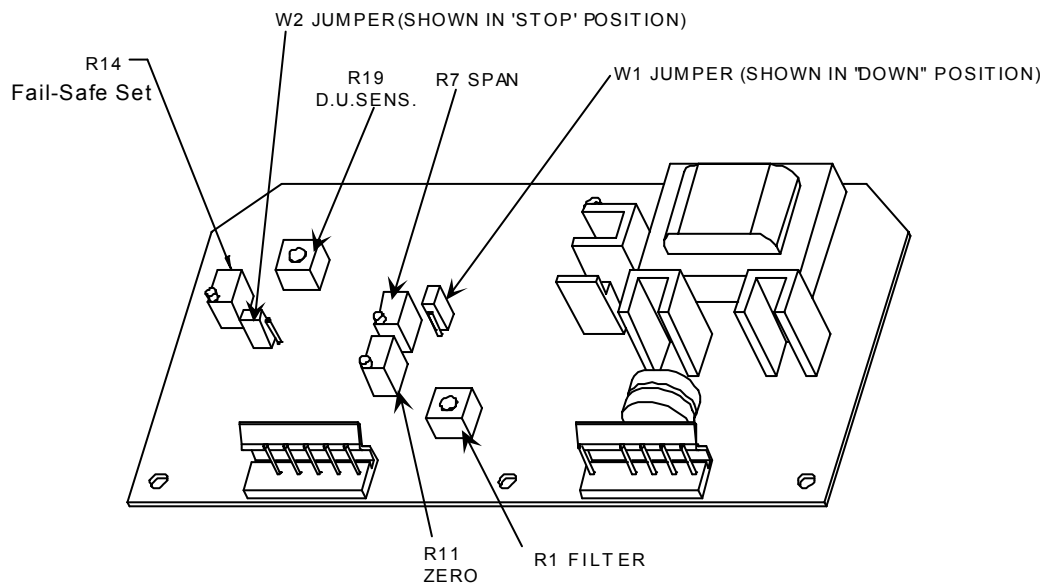

Figure 4-5 Motor Positioner Board

4.7.5 Filter Settings

If the input signal to the Motor Positioner contains transients or spurious signals, hunting or chattering of the actuator may occur. Use the FILTER potentiometer (R1) to smooth the input signal. Turn R1 clockwise to increase filtering.

4.7.6 Deadband and Sensitivity Settings

It is sometimes desirable to introduce some amount of “deadband” between the Motor Positioner and the actuator. (Within this “deadband” zone, the actuator can be moved manually for some distance back and forth without causing a correcting signal from the Motor Positioner.)

The adjustment for “deadband” or “Actuator Sensitivity” is potentiometer R19, labeled “D.U.Sens”. Turn R19 counterclockwise to increase the amount of deadband. The adjustment can be made from 0.2 % span with R19 turned fully clockwise to 5 % with R19 turned fully counterclockwise.

4.8 Output Board Calibration

The 10260A Series Actuator is available with one of three output boards. The first is the 0/4-20 mA Output board, the next is the Slidewire Emulation board. Finally, there is a basic NO output board that provides signal conditioning and CW/CCW reversing circuitry for the non-contact sensor. (This is used on models with 0/4-20 mA input and no output.)

4.8.1 0/4-20 mA PWA Output Board

The 10260A Series Actuator comes already calibrated from the factory. If it becomes necessary to do a calibration in the field, adjust the 4-20 mA output using the procedure below.

1. Locate the 4-20 mA output board that is positioned over the control shaft.
2. If actuator is set for CCW operation, position the actuator to 0 % span (either manually with the handwheel or auto/manual switch or for units with a Motor Positioner board, by inputting 0/4 mA input signal) and go to step 3. If actuator is set for CW operation, it will need to be set back to CCW operation to do the first step of the calibration. To set drive to CCW operation, see Section 4.9, Step 1 only. Position the actuator to 100 % of span on the right hand side scale pointer manually or with the auto/manual electric switch or for drives with a Motor Positioner board, input a 0/4 mA input signal.
3. Connect a precision voltmeter, + and – leads, to a 250 ohm shunt resistor on the 4-20 output signal terminals on the terminal block (Refer to Terminal Block Wiring diagram to locate terminals).
4. Read the voltage. The reading should be at 1 volt \pm 0.75 % of span (\pm 0.03 volts for 1 – 5 volt output).
5. If the reading is incorrect, adjust R2 (see Figure 4-6) until the reading is in line.
6. Position the actuator to 100 % (0 % for CW pointers) of span and make another reading.
7. The voltage should read 5 volts, \pm 0.75 % of span (\pm 0.03 volts).
8. If the reading is incorrect, adjust R1 (see Figure 4-6) until the reading comes into line.
9. You must then reposition the actuator to the 0 % (100 % for CW pointers) of span position and take another reading.
10. If the reading is out of line, repeat steps 5 through 8 until readings at both the 0 % and 100 % positions are in line.

The following additional steps are for CW units only. The adjustments that are made here will cause the actuator to reposition itself, similar to the Motor Positioner board adjustments. The actuator must be powered and must be in auto mode.

11. Set actuator back to CW operation. Switch the W10 jumper back to the 2_3 position and select “CW” on the terminal block CW/CCW switch.
12. Set the actuator to the 0 % position either manually with the handwheel or auto/manual switch or for units with a Motor Positioner board, by inputting a 0/4 mA input signal. Output should read 1 Vdc, \pm 0.75 % of span (\pm 0.03 volts) and actuator should be positioned at 0 % span on scale.
13. If reading is incorrect or actuator is not positioned at 0 % span, adjust R3 (see Figure 4-6) until the reading is in line, and actuator is at 0 % position.
Adjusting R3 will cause actuator movement (for units with a Motor Positioner board) and may be required to get actuator to 0 % position even if output is within tolerance.
14. Set the actuator to the 100 % position. Output should read 5 Vdc \pm 0.75 % of span (\pm 0.03 volts) and actuator is at 100 % position.
15. If the reading is incorrect or position is not at 100 %, adjust R4 (see Figure 4-6) until the reading is in line, and actuator is at 100 % position.

Adjusting R4 will cause actuator movement (for units with a Motor Positioner board) and may be required to get actuator to 100 % position even if output is in tolerance.

16. Reposition the actuator to the 0 % of span position and take another reading.
17. If the reading is still out of line, repeat steps 12 through 16 until both zero and span readings and positions are in line.

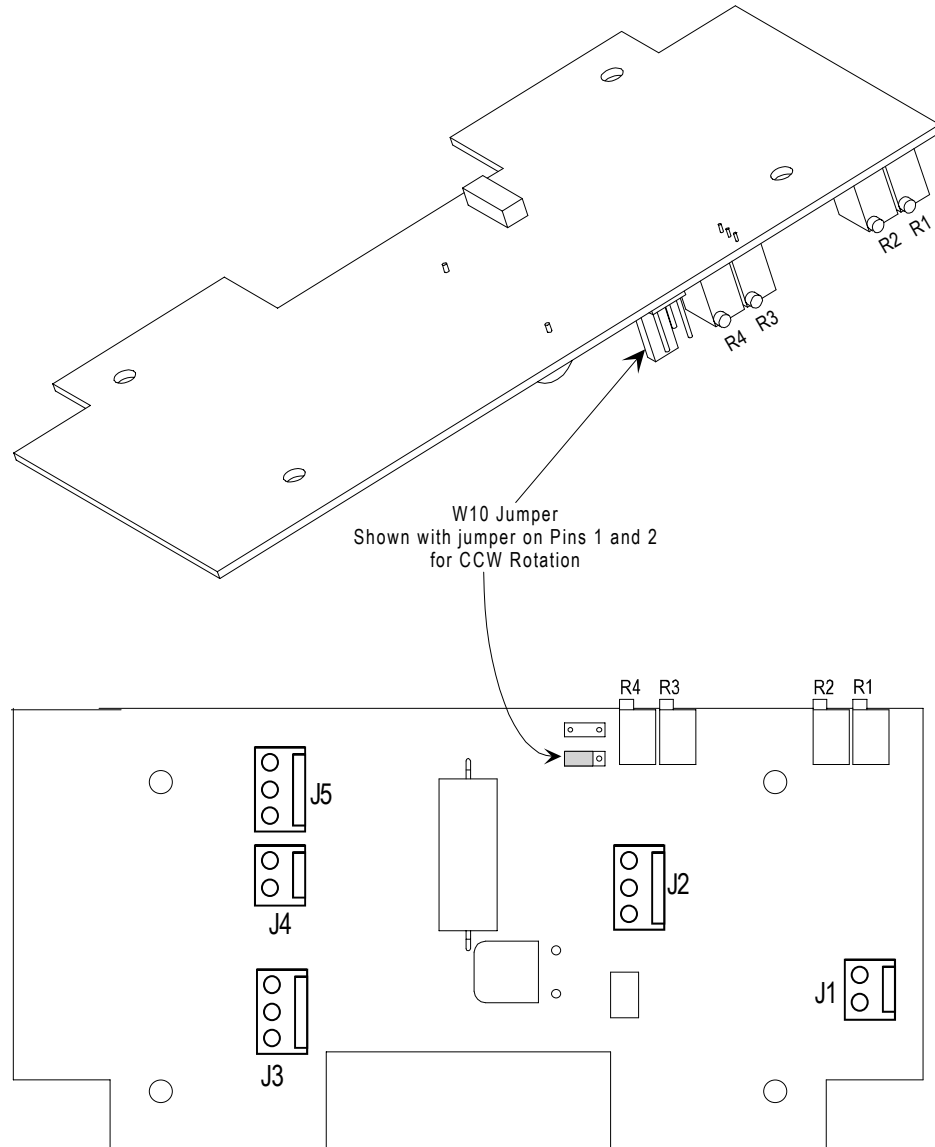

Figure 4-6 0/4-20 mA PWA Output Board

4.8.2 Slidewire Emulation

The Slidewire Emulation Output Card (51404886-003) can be calibrated for Slidewire Supply voltages between 1.0 Vdc and 20 Vdc. The Actuator leaves the factory with no Slidewire Supply connected to the terminals.

To calibrate the Slidewire Emulation output:

1. Remove power from the actuator, and connect the Slidewire Supply between the “H” and “L” terminals on the terminal plate. (Terminal 34 for the “L”, the low voltage side of the source and terminal 36 for the “H”, the high voltage side.) See Figure 3-11.
2. Connect a precision voltmeter, + and – leads, to terminals 35 and 34 on the terminal plate.
3. Apply the AC power to the actuator. Apply power from the Slidewire Source.
4. If actuator is set for CW operation, switch it to CCW operation. See Section 4.9, Step 1.
5. Position the actuator to the 25 % position on the CCW scale. (75 % position on CW scale.)
6. Read the voltage on the DVM. The reading should be 25 % of the Slidewire Supply \pm 0.75 % of span.
7. If the reading is incorrect, adjust R5 until the reading is within tolerance.
8. Position the actuator to the 75 % position on the CCW scale. (25 % position on the CW scale.)
9. Read the voltage on the DVM. The reading should be 75 % of the Slidewire Supply, \pm 0.75 % of span.
10. If the reading is incorrect adjust R59 until the reading comes into line.
11. Repeat steps 4 through 9 until the readings are within tolerance.
12. If CW operation is desired, switch actuator back to CW operation by following Section 4.9.

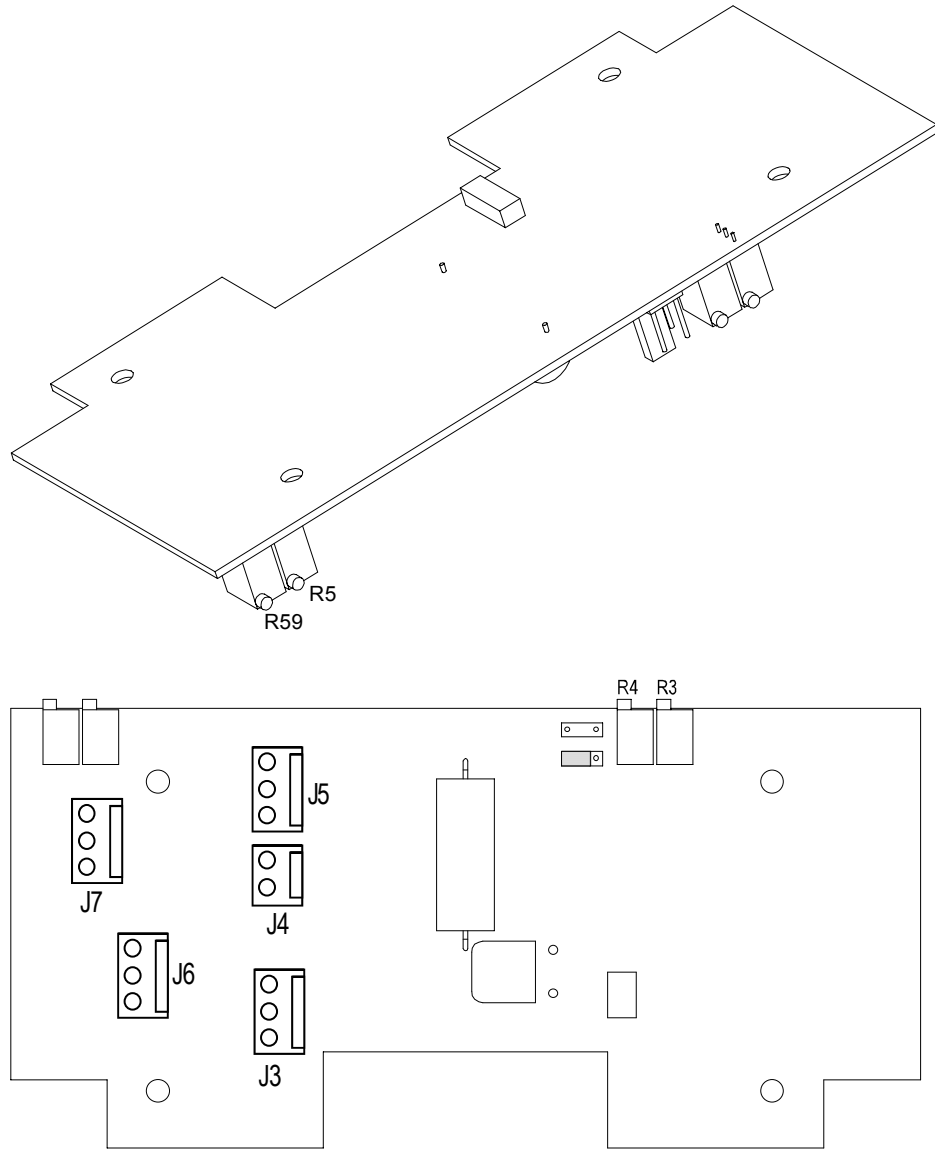

Figure 4-7 Slidewire Emulation Board

4.9 Reversal of Direction (Non contact sensor)

The CW/CCW Inverter Output Circuit is included on each of the versions of the NCS Output Card (51404886-001, 002, and 003). It can be calibrated by monitoring any of the output signals or using the scale on the actuator. For this procedure it is assumed that the pointer is set on the CW scale. (If the pointer is not changed to the CW scale replace 0 % with 100 % in this write up and 100 % with 0 %). The Actuator leaves the factory configured for CCW rotation. (Actuator should be calibrated for both CW and CCW operation and should not require recalibration when reversing direction.)

To change to CW rotation:

1. Remove power from the actuator, and change the jumper on W10 (see Figure 4-8) from the pin 1 to 2 position to the 2 to 3 position. Also place the toggle switch on the terminal block plate to the CW side.
2. Connect a precision voltmeter, + and – leads, to the output terminals or read the output on the scale of the actuator.
3. Apply the AC power to the actuator.
4. Set the input to the actuator to the 25 % point.
5. Read the voltage on the DVM or the scale position. The reading should be 25 % of the output span ± 0.75 % of span.
6. If the reading is incorrect, adjust R3 (see Figure 4-6) until the reading is within tolerance.
7. Set the input to the actuator to the 75 % point.
8. Read the voltage on the DVM or the actuator scale. The reading should be 75 % of the span, ± 0.75 % of span.
9. If the reading is incorrect adjust R4 (see Figure 4-6) until the reading comes into line.
10. Repeat steps 4 through 9 until the readings are within tolerance.

4.10 Reversal of Direction (Film Potentiometer)

The actuator leaves the factory configured for counterclockwise rotation.

To change to clockwise rotation:

1. Remove power from the actuator, and interchange the black lead with the yellow lead at terminals 35 and 37. Place the toggle switch on the terminal block plate to the CW side.
2. Move the pointer from the Left-hand scale to the Right-hand scale.
3. Apply the AC power to the actuator.
4. Set the input to the actuator to the 25% point.
5. The scale position should be 25% of the output range ± 0.75 % of span.
6. If the reading is incorrect, adjust R3 (see Figure 4-6) until reading is within tolerance.
7. Set the input to the actuator to the 75% point.
8. The scale position should be 75% of the output range ± 0.75 % of span.
9. If the reading is incorrect, adjust R4 (see Figure 4-6) until reading is within tolerance.
10. Repeat steps 4 through 9 until the readings are within tolerance.

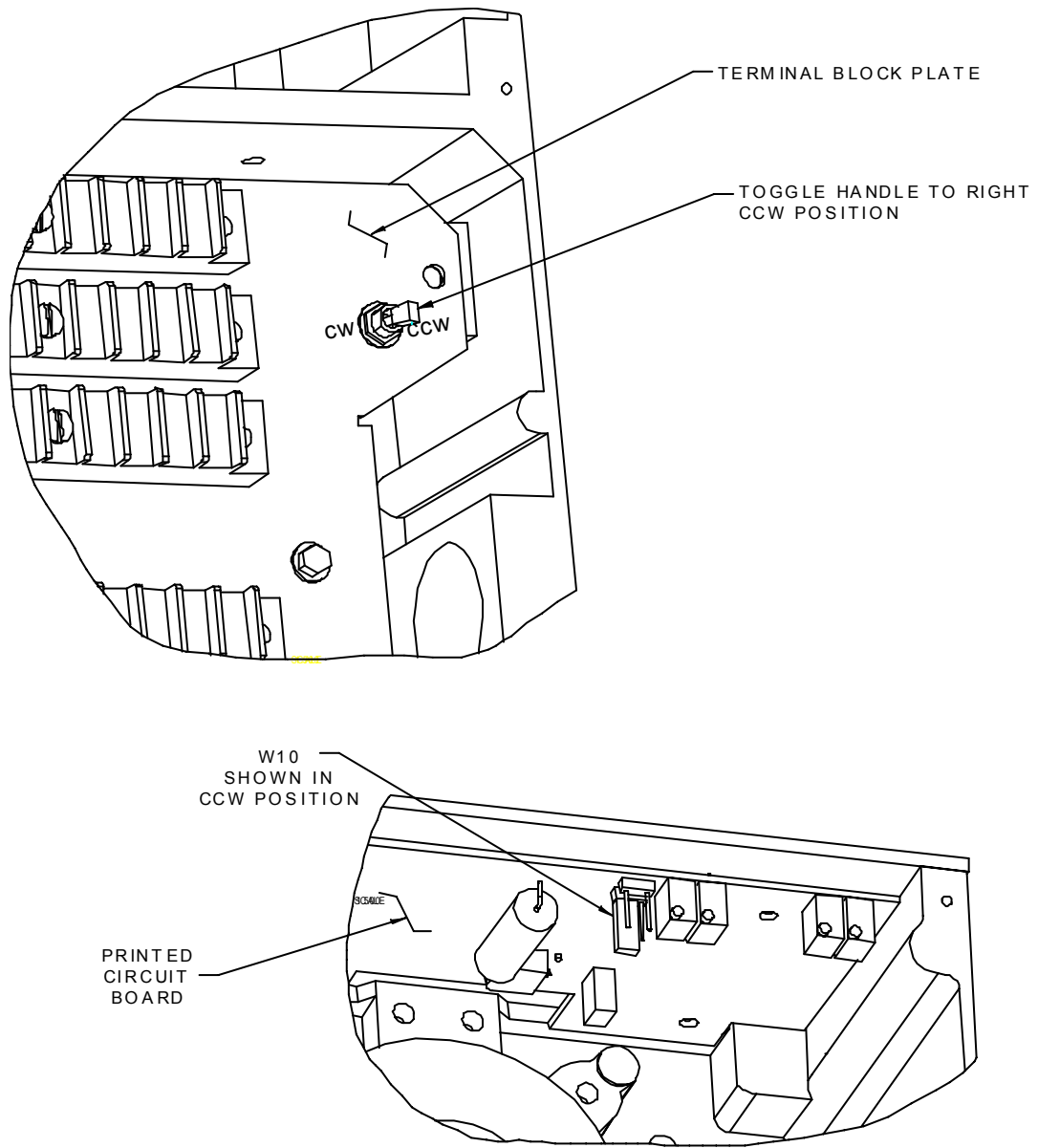

Figure 4-8 Switch Jumper for Reversal

5. Start-Up/Operation

5.1 Introduction

After the equipment is completely installed, wired, and the preliminary adjustment made, it is advisable to check the operation of the actuator and controlled device before using the equipment for actual control. In other words, operate the controlled device and check its direction of travel in response to an increase in the controlled variable and make sure it is correct for the process. Actuators having the optional Auto-Manual Switch must have the knob in the AUTO position.

This chapter provides a checklist which can be used to do a walk-through with the actuator before it is actually used for control.

5.2 Operations Checklist

1. Refer to customer's connection diagram supplied with each actuator to determine direction of actuator rotation.
2. If the process being controlled requires opposite actuator rotation from that supplied by the factory, this may be accomplished by following the field reversal procedure in Section 4.9.
3. To check the operation of the optional Auto-Manual Switch, move the knob to the C. W. and C.C. W. MANUAL: positions. The output shaft should rotate in the direction indicated by the knob.

6. Other Control Functions

6.1 Split Range

WARNING

While the unit is powered, a potentially lethal shock hazard exists inside the case.

Procedure for Actuator to Operate from 4 to 12 mA

To set span of printed circuit board to 8 mA:

- Set input to 0 mA and adjust Zero pot on printed circuit board to 0 % on actuator scale.
- Set input to 8 mA and adjust Span pot on printed circuit board to 100 % on actuator scale.

To set actuator to operate at 4 to 12 mA:

- Set input to 4 mA and adjust Zero pot on printed circuit board to 0 % on actuator scale.
- Set input to 12 mA and verify span at 100 % on actuator scale. No adjustment should be necessary.
- Replace Jumpers on printed circuit board.

Procedure for Actuator to Operate from 12 to 20 mA

To set span of printed circuit board to 8 mA:

- Set input to 0 mA and adjust Zero pot on printed circuit board to 0 % on actuator scale.
- Set input to 8 mA and adjust Span pot on printed circuit board to 100 % on actuator scale.

To set actuator to operate at 12 to 20 mA:

- Set input to 12 mA and adjust Zero pot on printed circuit board to 0 % on actuator scale.
- Set input to 20 mA and verify span at 100 % on actuator scale. No adjustment should be necessary.

Replace Jumpers on printed circuit board.

6.2 Master/Slave Arrangement

Introduction

With the motor positioner, the controlling signal for the actuator is a 4 to 20mA from a current output controller.

Unlike the position output controller the current output controller must produce a continuous analog signal or the actuator will revert to one of its failure modes. These are customer selected by movable jumper to remain where it is, downscale, upscale or to a predetermined position (adjustable).

Signal failure is not a problem since the available failure modes allow the user to predict the actuator position on signal loss.

6.2.1 Basic Flow Control

When the process variable signal is below set point, the current output increases (4 to 20mA) opening the valve.

At 4mA the zero adjustment on the motor positioner PCA is made for the low end of actuator travel.

At 20mA the span adjustment is used for the high end of actuator travel. The graph shows the linear relationship.

The adjustment pots are located on the PCA. The slidewire/switch housing cover on the actuator must be removed for access to all adjustments including the signal filter and deadband pots.

Controller set point governs valve position to obtain desired flow rate.

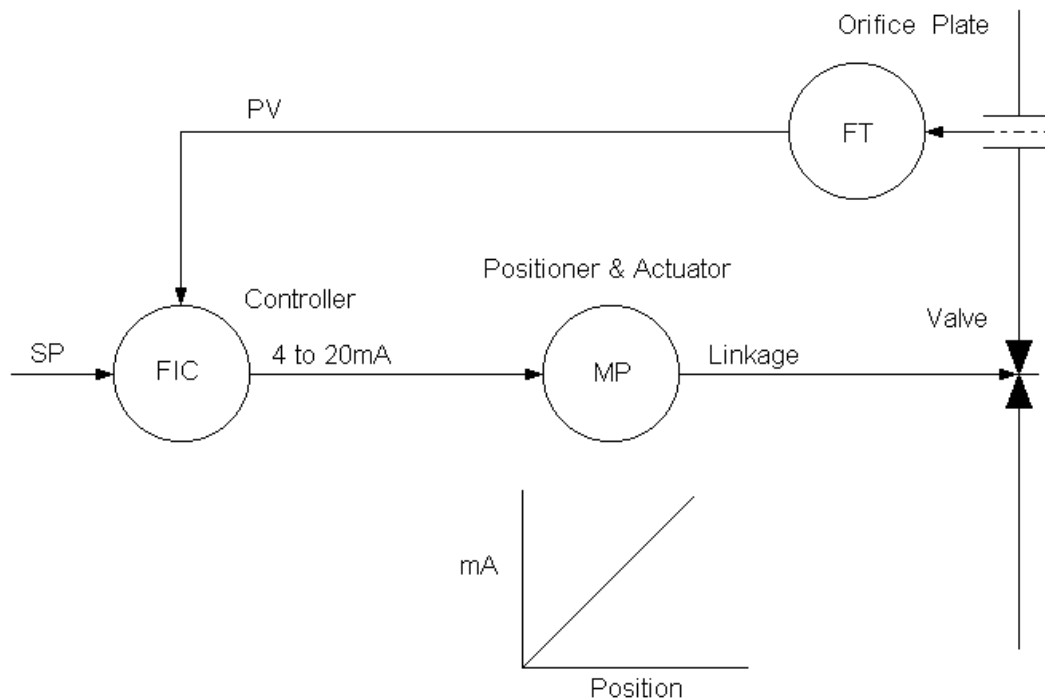

Figure 6-1 Flow Diagram

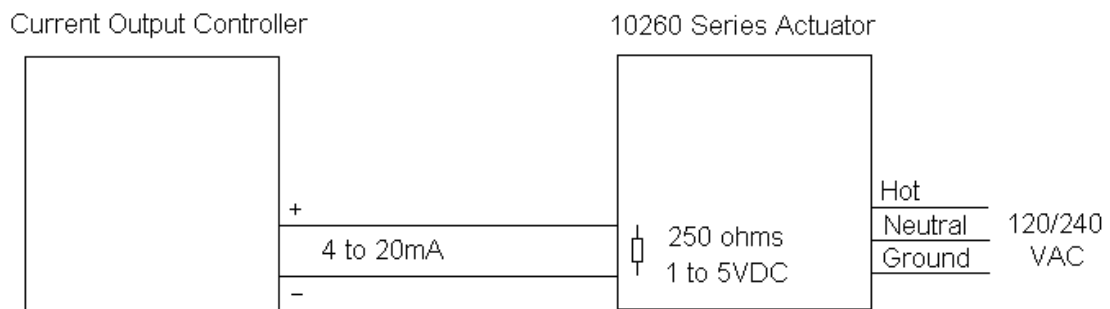

Figure 6-2 Interconnection Diagram

6.2.2 Proportional Flow using Multiple Actuators

The controller governs flow rate in one burner. Only that flow is measured. Since #2 and #3 motor positioners receive the same signal as #1 motor positioner, valves #2 and #3 will deliver the same amount of fuel. This is true when the span and zero adjustment are all set the same as in curve 2 of the graph. Other relationships between units exist if the span adjustment (3) for ratio or if the zero adjustment is changed (1) for bias.

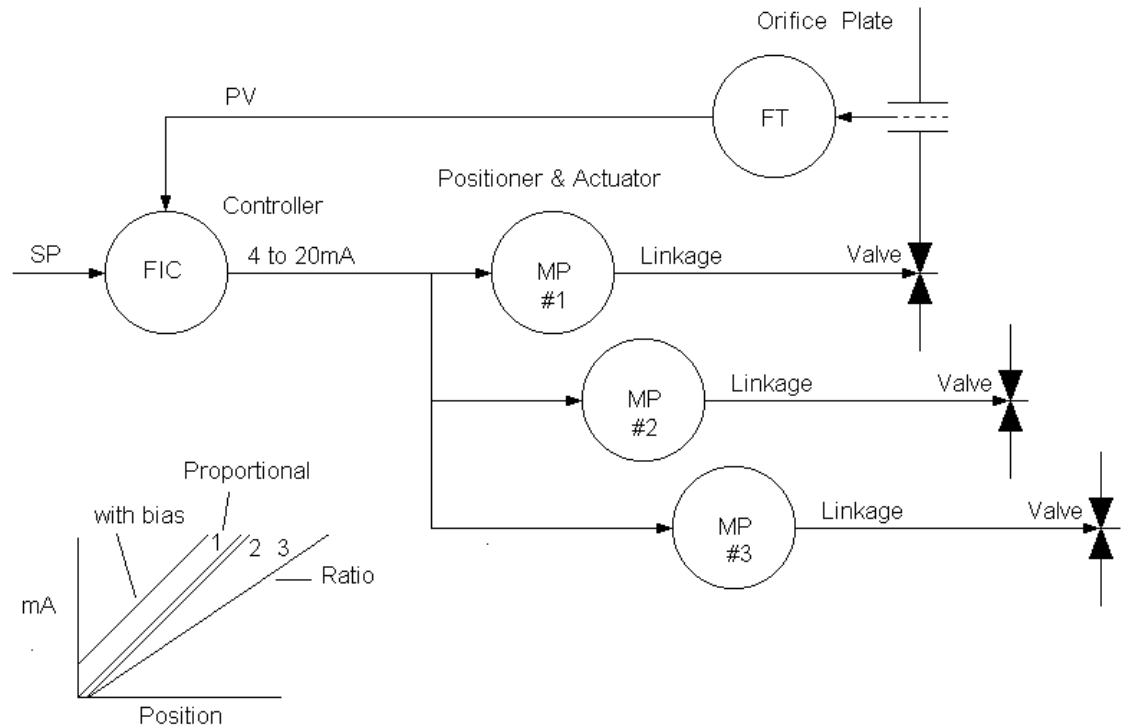

Figure 6-3 Proportional Flow Using Multiple Actuators

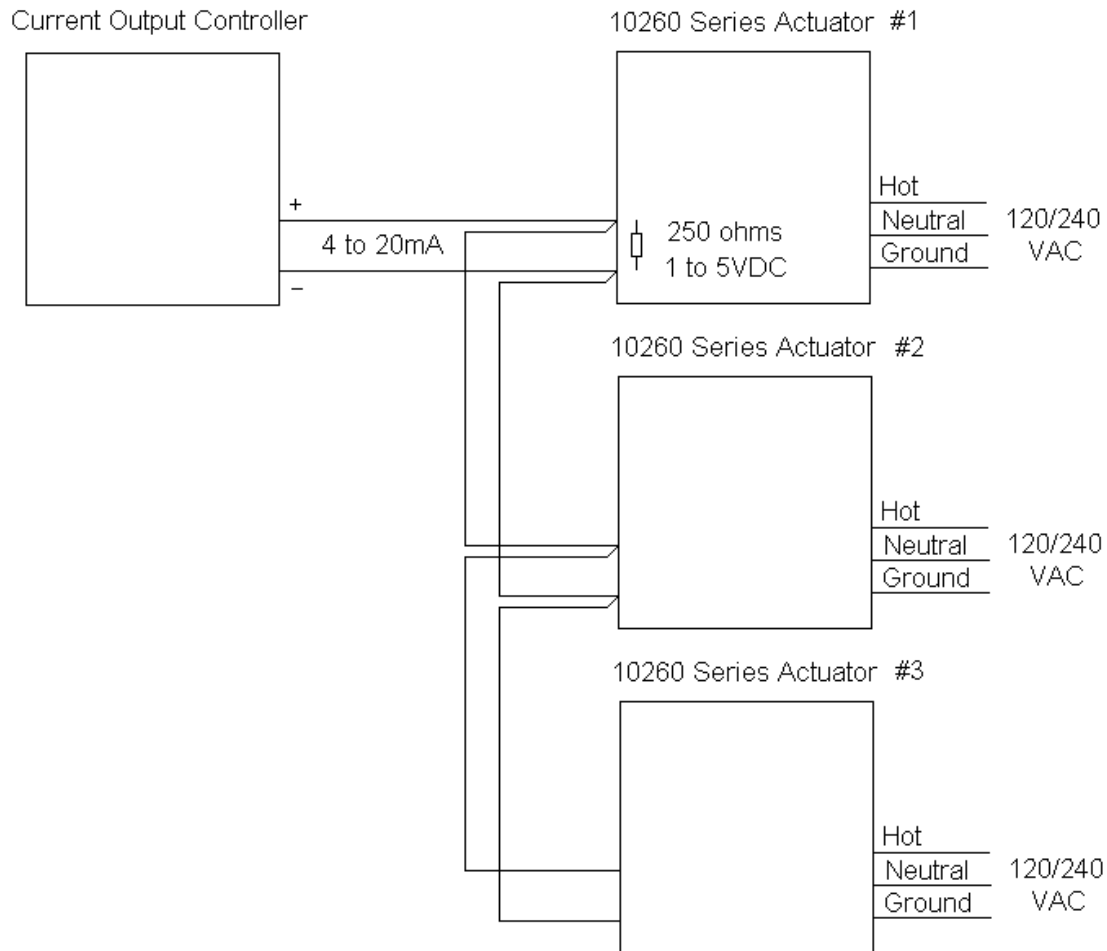

Figure 6-4 Multiple Actuator Interconnection Diagram

REFERENCE

The minimum recommended “zero” adjustment is 0.2 V. Below 0.11 V the positioner assumes a loss of signal and will drive the actuator to the customer selected position. The maximum zero adjustment is 3.0 V if full travel is desired (span set at 5.0 V). Minimum span setting is 1.0 V, maximum span setting is 5.0 V. To insure failsafe action, in the event that the input is disconnected, a 10 K-ohm bleeder resistor should be placed across the input terminals.

6.2.3 Split Valve Configuration

A common heat or cool type process requires two valves. In this case the controller has only one output. The two motor positioners are calibrated differently, one responds to 4 mA to 12 mA and the other responds to 12 mA to 20 mA. At 12 mA both valves are closed, one opening below 12 mA and the other above 12 mA. It is also easy to have deadband in the center where both valves are closed, or overlap where both are open. Deadband is obtained with the zero and span adjustments on the motor positioner PCA.

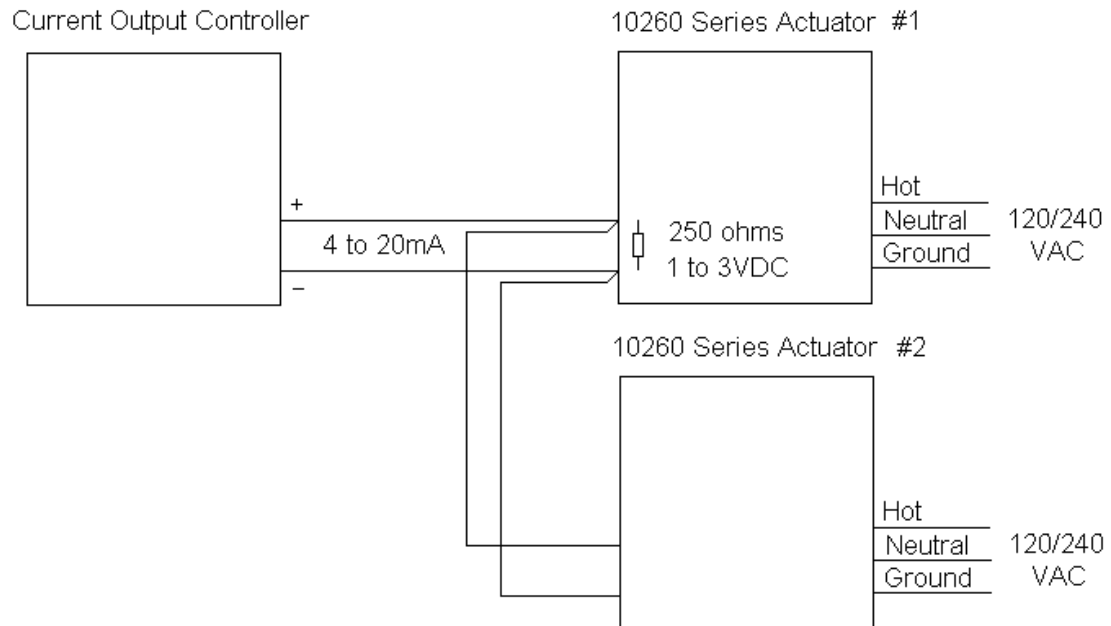

Figure 6-5 Interconnection Diagram

7. Maintenance

7.1 Introduction

There is some basic maintenance that is recommended for the 10260A Series Actuators. The Non-contact Sensor, Motor Positioner, Slidewire Emulator, and 4-20 Output Board require no maintenance or servicing under normal conditions.

If there is a problem, this chapter provides the user with the information needed to return the 10260A Series Actuator to peak performance.

7.2 Basic Maintenance

7.2.1 Main Gear Lubrication

The main gears are lubricated at the factory with Texaco Starplex 2 EP grease. Honeywell recommends visual inspection of the worm and worm gear lubricant during major shutdown periods. Apply lubricant as necessary to assure that the gears are adequately protected.

To perform the inspection, first loosen the side control compartment cover fasteners and then remove the top cover plate. After the inspection, check the gaskets for damage and replace if necessary. Re-install the top cover first and then tighten the side control cover fasteners.

7.2.2 Spur Gear Lubrication

Honeywell recommends during major shutdown periods that the gear cover be removed and spur gears inspected and lubricated by apply a coating of Texaco Starplex 2 EP grease or equivalent.

7.2.3 Non-Contact Sensor

There is no maintenance required.

7.2.4 Motor Positioner

There is no maintenance required.

7.2.5 Replacing the Fuses



WARNING

Disconnect power before opening the instrument case to replace the fuse(s). A potentially lethal shock hazard exists inside the case if the unit is opened while powered.

8. Replacement/Recommended Spare Parts

8.1 Introduction

This chapter provides the user with a complete list of all the spare parts that may be needed for the 10260A Series Actuators and the optional equipment.

8.2 Motor Kits

Kit #51205551-501 Motor 1026 (1, 2, 4, 6) 120 V 50/60 Kit

Part Description	Quantity
MOTOR	1
CAPACITOR, MOTOR 7.5uf	1
GASKET KIT (10260)	1
INSTRUCTIONS, MOTOR	1

Kit #51205551-502 Motor 10263 120 V 50/60 Kit

Part Description	Quantity
MOTOR	1
CAPACITOR, MOTOR 11uf - 60 HZ	1
CAPACITOR, MOTOR 13uf - 50 HZ	1
GASKET KIT (10260)	1
INSTRUCTIONS, MOTOR	1

Kit #51205551-503 Motor 1026 (7, 8, 9) 120 V 50/60 Kit

Part Description	Quantity
MOTOR	1
CAPACITOR, MOTOR 14uf	1
INSTRUCTIONS, MOTOR	1
GASKET KIT (10260)	1

Kit #51205551-504 Motor 1026 (1, 2, 4, 6, 7, 8, 9) 240 V 50/60 Kit

Part Description	Quantity
MOTOR	1
CAPACITOR, MOTOR	1
CAPACITOR, MOTOR	1
GASKET KIT (10260)	1
INSTRUCTIONS, MOTOR	1

Kit #51205551-505 Motor 10263 240 V 50/60 Kit

Part Description	Quantity
MOTOR	1
CAPACITOR, MOTOR	1
CAPACITOR, MOTOR	1
GASKET KIT (10260)	1
INSTRUCTIONS, MOTOR	1

Kit #51205551-506 Motor 10265 120 V 50/60 Kit

Part Description	Quantity
MOTOR	1
CAPACITOR, MOTOR 11uf - 60 HZ	1
CAPACITOR, MOTOR 13uf - 50 HZ	1
GASKET KIT (10260)	1
INSTRUCTIONS, MOTOR	1

Kit #51205551-507 Motor 10265 240 V 50/60 Kit

Part Description	Quantity
MOTOR	1
CAPACITOR, MOTOR	1
CAPACITOR, MOTOR	1
GASKET KIT (10260)	1
INSTRUCTIONS, MOTOR	1

8.3 Idler Gear Kits

Kit #51205552-501 Idler Gear 1026 (1, 2, 4, 6, 7) Fiber (2) Kit

Part Description	Quantity
IDLER GEAR ASSY (FIBER)	2
GASKET KIT (10260)	1
INSTRUCTIONS, IDLER GEAR	1

Kit #51205552-502 Idler Gear 1026 (8, 9) Steel (2) Kit

Part Description	Quantity
IDLER GEAR ASSY (STEEL)	2
GASKET KIT (10260)	1
INSTRUCTIONS, IDLER GEAR	1

Kit #51205552-503 Idler Gear 1026 (3, 5) Steel (2) Kit

Part Description	Quantity
IDLER GEAR ASSY (STEEL)	1
GASKET KIT (10260)	1
INSTRUCTIONS, IDLER GEAR	1

8.4 Non-Contact Sensor, Film Potentiometer, Output Board Limit/Aux Switch and CAM Kits

Kit #51404926-501 Non-Contact Sensor (NCS) Replacement

Part Description	Quantity
NCS	1
GAGE, SENSOR ALIGNMENT	1
SCREWS, #4-40 X 5/16	4
LOCKWASHER, #4	4
INSTRUCTIONS NCS	1
GASKET KIT (10260)	1

Kit #51451656-507 Film Potentiometer Kit

Part Description	Quantity
FILM POTENTIOMETER 1000 OHMS, 90 DEGREES	1
GASKET SET FOR 1 1026X UNIT	1
1026XA WIRING DIAGRAM FILM POTENTIOMETER	1

Kit #51404885-501 Power Inverter/NCS Board

Part Description	Quantity
POWER INVERTER/NCS PWA	1
GASKET KIT (10260)	1
SCREW, #6-32 X 3/8	4
LOCKWASHER, #6	4
INSTRUCTIONS, INVERTER	1

Kit #51404885-502 4-20 Output Board

Part Description	Quantity
4-20 OUTPUT BOARD	1
GASKET KIT (10260)	1
SCREW, #6-32 X 3/8	4
LOCKWASHER, #6	4
INSTRUCTIONS, 4-20 OUTPUT	1

Kit #51404885-503 Slidewire Emulator Board

Part Description	Quantity
SLIDEWIRE EMULATOR BOARD	1
GASKET KIT (10260)	1
SCREW, #6-32 X 3/8	4
LOCKWASHER, #6	4
INSTRUCTIONS, SLIDEWIRE EMULATION	1

Kit #51404978-501 4-20 mA Input (CAT/PAT) Board (120V)

Part Description	Quantity
CAT/PAT (120V)	1
GASKET KIT (10260)	1
30 OHM RESISTOR KIT	1
INSTRUCTIONS, CAT/PAT	1

Kit #51404978-502 4-20 mA Input (CAT/PAT) Board (240 V)

Part Description	Quantity
CAT/PAT KIT (240V)	1
GASKET KIT (10260)	1
30 OHM RESISTOR KIT	1
INSTRUCTIONS, CAT/PAT	1

Kit #51404978-503 4-20 mA Input (CAT/PAT) Board with Cables (120 V)

Part Description	Quantity
CAT/PAT PWA KIT (120V)	1
CABLE ASSY, INPUT CAT/PAT	1
CABLE ASSY, POWER IN/ MOTOR OP	1

Kit #51404978-504 4-20 mA Input (CAT/PAT) Board with Cables (240 V)

Part Description	Quantity
CAT/PAT PWA KIT (120V)	1
CABLE ASSY, INPUT CAT/PAT	1
CABLE ASSY, POWER IN/ MOTOR OP	1

Kit #51309623-502 Auto/Manual Switch Kit

Part Description	Quantity
AUTO/MANUAL SWITCH ASSY(10260A)	1
LABEL	2
KNOB	3
INSTRUCTIONS, AUTO/MANUAL	4
GASKET KIT (10260)	1

Kit #51205550-501 Switch Kit

Part Description	Quantity
SWITCH BRACKET	1
SCREWS, #10-32 X 1/2	3
LOCKWASHER, #10	3
WASHER (N) #10	3
SWITCH SUPPORT BRACKET	1
SWITCHES	6
SWITCH INSULATOR	2
SCREW, #4-40 X .75	4
LOCKWASHER, #4	4
WASHER (N) #4	4
SCREW, #4-40 X 1.25	4
SCREW, #4-40 X 1.75	4
CABLE ASSY, SWITCH	3
INSTRUCTIONS, SWITCH KIT	1
GASKET KIT (10260)	1

Note: Cam kit 51205553-501 also required if adding switches

Kit #51205553-501 Cam Assembly Kit

Part Description	Quantity
BUSHING, CAM	1
SCREW, SOC SET #10-32 X 1/4	2
LOCKING NUT	1
WASHER, TOOTHED	6
WASHER, CAM	5
SPACER, CAM	3
CAM	5
INSTRUCTIONS, CAM	1

8.5 Linkage Parts/Kits

Turnbuckle Kit				Pipe Kit			
up to 75 lb-ft (100 NM)	Overall linkage length (inches/cm)			Overall linkage length (inches/cm)*			
	min.	max.	kit number	min.	max.	pipe size	kit number
	12	16	083381	24	72	1"	083384
	16	20	083382	24	120	1 ½"	083385
	20	24	083383	-	-	-	-
150 to 300 lb-ft (200 to 410 NM)	Overall linkage length (inches)			Overall linkage length (inches)*			
	min.	max.	kit number	min.	max.	pipe size	kit number
	12	16	083381	24	28	1"	083384
	16	20	083382	24	84	1 ½"	083385
	20	24	083383	24	120	2"	083386

8.6 Accessories

Part	Number
5" Crankarm kit	51309967-501
12" Crankarm kit	51452160-501
HAL Software	51197910-001
Gasket kit	
Transformer	51404947-501
250 ohm resistor	070756

8.7 Non-Contact Position Sensor Field Upgrade Kits

NOTE: These kits are for upgrading 10260A Actuators. Kits for upgrading existing 10260 Actuators are covered separately.

Kit #51205568-501 NCS 4-20 mA Input and 4-20 mA Output Upgrade Kit (120 V)

Part Description	Quantity
NC SENSOR PWA KIT	1
4-20OP INVERTER/RVIT-Z PWA	1
CAT/PAT 4-20 INPUT W/CABLES (120 V)	1
NCS BRACKET	1
SCREWS, #10-32 X 3/4	4
LOCKWASHER, #10	4
WASHER (N) #10	4
FRAME, PWA	1
SCREW, #10-32 X 1/2	1
INSTRUCTIONS, NCS UPGRADE W/4-20 OP	1
CABLES, NCS POWER	1
CABLES, POWER IP/MOTOR OP	1
CABLE, 4-20 IP	1

Kit #51205568-502 NCS 4-20 mA Input and 4-20 mA Output Upgrade Kit (240 V)

Part Description	Quantity
NC SENSOR PWA KIT	1
4-20OP INVERTER/RVIT-Z PWA	1
CAT/PAT 4-20 INPUT W/CABLES (240 V)	1
NCS BRACKET	1
SCREWS, #10-32 X 3/4	4
LOCKWASHER, #10	4
WASHER (N) #10	4
FRAME, PWA	1
SCREW, #10-32 X 1/2	1
INSTRUCTIONS, NCS UPGRADE W/4-20 OP	1
CABLES, NCS POWER	1
CABLES, POWER IP/MOTOR OP	1
CABLE, 4-20 IP	1
CABLE, 4-20 OP	1

Kit #51205568-503 NCS 4-20 Output Upgrade Kit

Part Description	Quantity
NC SENSOR PWA KIT	1
4-20 OP/INVERTER-NCS PWA KIT	1
NCS BRACKET	1
SCREWS, #10-32 X 3/4	4
LOCKWASHER, #10	4
WASHER (N) #10	4
FRAME, PWA	1
SCREW, #10-32 X 1/2	1
INSTRUCTIONS, NCS UPGRADE W/4-20 OP	1
CABLES, NCS POWER	1
CABLE, 4-20 OP	1

Kit #51205568-504 NCS Slidewire Emulation Upgrade Kit

Part Description	Quantity
NC SENSOR PWA KIT	1
SLIDEWIRE EMULATION/INVERTER-NCS PWA KIT	1
NCS BRACKET	1
SCREWS, #10-32 X 3/4	4
LOCKWASHER, #10	4
WASHER (N) #10	4
FRAME, PWA	1
SCREW, #10-32 X 1/2	1
INSTRUCTIONS, NCS UPGRADE W/4-20 OP	1
CABLES, NCS POWER	1

Kit #51205568-505 NCS 4-20 mA Input Upgrade Kit (120 V)

Part Description	Quantity
NC SENSOR PWA KIT	1
POWER INVERTER/RVIT-Z PWA	1
CAT/PAT 4-20 INPUT W/CABLES (120 V)	1
NCS BRACKET	1
SCREWS, #10-32 X 3/4	4
LOCKWASHER, #10	4
WASHER (N) #10	4
FRAME, PWA	1
SCREW, #10-32 X 1/2	1
INSTRUCTIONS, NCS UPGRADE W/4-20 OP	1
CABLES, NCS POWER	1
CABLES, POWER IP/MOTOR OP	1
CABLE, 4-20 IP	1

Kit #51205568-506 NCS 4-20 mA Input Upgrade Kit (240 V)

Part Description	Quantity
NC SENSOR PWA KIT	1
POWER INVERTER/RVIT-Z PWA	1
CAT/PAT 4-20 INPUT W/CABLES (240 V)	1
NCS BRACKET	1
SCREWS, #10-32 X 3/4	4
LOCKWASHER, #10	4
WASHER (N) #10	4
FRAME, PWA	1
SCREW, #10-32 X 1/2	1
INSTRUCTIONS, NCS UPGRADE W/4-20 OP	1
CABLES, NCS POWER	1
CABLES, POWER IP/MOTOR OP	1
CABLE, 4-20 IP	1

8.8 Honeywell Actuator Linkage Analysis Software (HAL)

Part Number: 51197910-001

8.9 Replacement Fuses (Not for Sale)

Bussmann GDB1.6: 1.6 Amp Fast
 Littlefuse 312001: 1.0 Amp Fast

8.10 Film Potentiometer Upgrade Kits

Kit #51205568-507 Film Potentiometer Upgrade Kit

Part Description	Quantity
HEX STANDOFF	1
NCS BRACKET	1
MOUNTING PLATE - POTENTIOMETER	1
SEMS #4-40 X .310LG PNPSTL	2
SEMS-EXT 8-32 X .50 PHPNSS	1
SEMS-EXT 10-32 X .75 PHPNSS	4
WIRE CAP	1
6-32 NUT WASHER ASSY	2
POT, 1K, DUAL ELEMENT, 90 DEG	1
POT ACTUATOR 10260A	1
SET SCREW 3/32 X 3-48 10260A	1
RESISTOR 110 OHMS 1% 1/2W	1
RESISTOR 158 OHMS 1% 1/2W	1
1026XA Wiring Diagram Film Potentiometer	1
Gasket set for 1 1026X Unit	1

Kit #51205568-508 Film Pot, 4 to 20mA Input 120VAC Upgrade Kit

Part Description	Quantity
HEX STANDOFF	1
8-32 NUT WASHER ASSY	2
THDFRMPANSCAD1/4X6-32 TAPTITE	4
NCS BRACKET	1
CAT/PAT INPUT CAB ASSY 10260A	1
MOUNTING PLATE - POTENTIOMETER	1
-OHM 30. 30. W 5%	1
4-20 IP CAT/PAT 120V (10260A)	1
SEMS #4-40 X .310LG PNPSTL	2
SEMS-EXT 8-32 X .50 PHPNSS	1
SEMS-EXT 10-32 X .75 PHPNSS	4
WIRE CAP	1
RESISTOR-SHUNT	1
6-32 NUT WASHER ASSY	2
POT, 1K, DUAL ELEMENT, 90 DEG	1
POT ACTUATOR 10260A	1
SET SCREW 3/32 X 3-48 10260A	1
RESISTOR 110 OHMS 1% 1/2W	1
RESISTOR 158 OHMS 1% 1/2W	1
1026XA Wiring Diagram Film Potentiometer	1
Gasket set for 1 1026X Unit	1

Kit #51205568-509 Film Pot, 4 to 20mA Input 240VAC Upgrade Kit

Part Description	Quantity
HEX STANDOFF	1
8-32 NUT WASHER ASSY	2
THDFRMPANSCAD1/4X6-32 TAPTITE	4
NCS BRACKET	1
CAT/PAT INPUT CAB ASSY 10260A	1
MOUNTING PLATE - POTENTIOMETER	1
-OHM 30. 30. W 5%	1
4-20 IP CAT/PAT 240V (10260A)	1
SEMS #4-40 X .310LG PNPSTL	2
SEMS-EXT 8-32 X .50 PHPNSS	1
SEMS-EXT 10-32 X .75 PHPNSS	4
WIRE CAP	1
RESISTOR-SHUNT	1
6-32 NUT WASHER ASSY	2
POT, 1K, DUAL ELEMENT, 90 DEG	1
POT ACTUATOR 10260A	1
SET SCREW 3/32 X 3-48 10260A	1
RESISTOR 110 OHMS 1% 1/2W	1
RESISTOR 158 OHMS 1% 1/2W	1
1026XA Wiring Diagram Film Potentiometer	1
Gasket set for 1 1026X Unit	1

9. Troubleshooting

9.1 Introduction

Table 9-1 indicates some of the observable symptoms of failure that can be identified by noting the erratic actuator functions.

Symptoms

Compare the actuator’s symptoms with those in Table 9-1 and refer to the indicated subsections for the appropriate troubleshooting procedures.

Table 9-1 Observable Symptoms of Failure

Symptoms	See Subsection
Actuator Current Output does not function.	9.2.1
Actuator Slidewire Output does not function.	9.2.2
Non-Contact CW/CCW operation is not correct.	9.2.3
Actuator does not control to proper position.	9.2.4
Auto/Manual Switch does not operate correctly.	9.2.5
CW/CCW switch does not operate correctly.	9.2.6
UP/Down Actuator action is not correct.	9.2.7

9.2 Troubleshooting Procedures

Overview

The troubleshooting procedures for the observable symptoms of failure are presented in the same order as they appear in Table 9-1. Each procedure includes what to do if you have that particular failure, as well as instructions for accomplishing the task, or a cross-reference to instructions elsewhere in the manual.

Equipment needed

You will need the following equipment in order to troubleshoot the symptoms listed in the tables that follow:

- DC Milliammeter – mA dc
- Calibration source – Volt, mA, etc.
- Digital Voltmeter

Safety precautions

Exercise appropriate safety precautions when troubleshooting the actuator operation.



WARNING

While the unit is powered, a potentially lethal shock hazard exists inside the case. Do not open the case while the unit is powered. Do not access the terminals while the unit is powered.

9.2.1 Actuator Current Output does not function.

Table 9-2 explains how to troubleshoot the actuator current output failure.

Table 9-2 Troubleshooting Current Output

Step	What to Do	How To Do it or Where to Find the Instructions
1	Check that the cables are plugged into the correct headers on the NCS Output Board.	On the NCS Output Board insure that the following are connected: (See Figure 4-6.) J5 – BRN, BRN, YEL; J2 – BLU, BLU, VIO; J3 – RED, GRN, WHT; J1 – GRY, YEL J4 – ORN, YEL (If Motor Positioner board present)
2	Check that a load resistor is connected to the output.	After removing the GRY and YEL wires from TB-32 and 33, measure, using an ohmmeter, the load resistor to verify it is connected between terminals TB-32 and 33. See Figure 3-11.
3	Check the input signal to the NCS Output Board.	Using a DVM measure the voltage between the pins on W11. The voltage should be in the range of 0 Vdc to 1.25 Vdc. See Figure 4-4.
4	Check/Recalibrate.	Refer to Section 4 to check calibration and to recalibrate. First check Section 4.6 for proper positioning and calibration of non-contact sensor.
5	Replace the NCS Output Board.	Refer to the replacement procedure in Section 8 – Replacement/Recommended Spare Parts.

9.2.2 Actuator Slidewire Output does not function.

Table 9-3 explains how to troubleshoot the actuator Slidewire Output failure.

Table 9-3 Troubleshooting Slidewire Output

Step	What to Do	How To Do it or Where to Find the Instructions
1	Check that the cables are plugged into the correct headers on the NCS Output Board.	On the NCS Output Board insure that the following are connected: (See Figure 4-7.) J5 – BRN, BRN, YEL; J7 – ORN, ORN, GRY; J3 – RED, GRN, WHT: J6 – RED, YEL, BLU. J4 – ORN, YEL (If Motor Positioner board is present.)
2	Check that the external controller is supplying a slidewire voltage supply.	Using the Digital Voltmeter measure the voltage from pin 34 to pin 36 on TB. This voltage should be in the range of 1.000 Vdc to 20 Vdc. See Figure 3-11.
3	Check the input signal to the NCS Output Board.	Using a DVM measure the voltage between the pins on W11. The voltage should be in the range of 0 to 1.25 Vdc. See Figure 4-4.
4	Check/Recalibrate.	Refer to Section 4 to check calibration and to recalibrate. First check Section 4.6 for proper positioning and calibration of non-contact sensor.
5	Replace the NCS Output Board.	Refer to the replacement procedure in Section 8 – Replacement/Recommended Spare Parts.

9.2.3 Actuator CW/CCW operation is not correct.

Table 9-4 explains how to troubleshoot the actuator for proper CW/CCW operation.

Table 9-4 Troubleshooting CW/CCW Operation

Step	What to Do	How To Do it or Where to Find the Instructions
1	Check that the cables are plugged into the correct headers on the NCS Output Board.	On the NCS Output Board insure that the following are connected: (See Figure 4-6.) J5 – BRN, BRN, YEL J3 – RED, GRN, WHT W10 – jumper pins 1 to 2 – CCW W10 – jumper pins 2 to 3 – CW J4 – ORN, YEL (If Motor Positioner board is present.)
2	Check that the shaft turns correctly for CCW drive.	If actuator is used in CCW direction and input is increasing measure, using a DVM, the voltage at W11 See Figure 4-4. It should be increasing from 0 Vdc to 1.25 Vdc as input increases and shaft rotates CCW. If this is not the case go back to STEP 1 and check W10 jumper position. See Figure 4-6.
3	Check that shaft turns correctly for CW drive	If actuator is used in CW direction and input is increasing measure, using a DVM, the voltage at W11. See Figure 4-4. It should be decreasing from 1.25 Vdc to 0 Vdc as input increases and shaft rotates CW. If this is not the case go back to STEP 1 and check W10 jumper position. See Figure 4-6.
4	Check/Recalibrate.	Refer to Section 4 to check calibration and to recalibrate. First check Section 4.6 for proper positioning and calibration of non-contact sensor.
5	Replace the NCS Output Board.	Refer to the replacement procedure in Section 8 – Replacement/Recommended Spare Parts.

9.2.4 Actuator does not control to the proper position.

Table 9-5 explains how to troubleshoot the actuator for the correct control operation.

Table 9-5 Troubleshooting Control Action on Actuator

Step	What to Do	How To Do it or Where to Find the Instructions
1	Check the connectors to the Motor Positioner Board.	Check to make sure connectors are securely seated in headers on Motor Position board. See Figure 4-5.
2	Check that cables are plugged into the correct headers on NCS output board.	Check to make sure connector is seated in header J4 on NCS board. See Figure 4-6.
3	Check NCS Output signal.	On NCS Output Card, using a DVM, check that the voltage across the pins of W11 (Figure 4-4) is in the range of 0 to 1.25 Vdc. Check that voltage is increasing for CCW operation and decreasing for CW operation.
4	Check input signal.	Using a DVM verify that the input signal at TB-30 to 31 (Figure 3-11) is in the range of 1 Vdc to 5 Vdc. If not check for the dropping resistor.
5	Check CW/CCW jumper	Upon change of input signal, if actuator travels to 0 % or 100 % check to make sure CW/CCW switch and jumper (Figure 4-6) are in correct positions.
6	Check/Recalibrate	Refer to Section 4 to recalibrate actuator. First check Section 4.6 for proper positioning and calibration of Non-contact Position Sensor.
7	Replace CAT/PAT Board.	Refer to the replacement procedure in Section 8 – Replacement/Recommended Spare Parts.

9.2.5 Auto/Manual Switch does not operate correctly.

Table 9-6 explains how to troubleshoot the actuator Auto/Manual Switch.

Table 9-6 Troubleshooting the Auto /Manual Switch

Step	What to Do	How To Do it or Where to Find the Instructions
1	Check the Auto/Manual Switch in Manual Mode (CCW).	Set the Auto/Manual Switch in the CCW position. Verify that shaft turns CCW (viewed from shaft end of actuator).
2	Check the Auto/Manual Switch in Manual Mode (CW).	Set the Auto/Manual Switch in the CW position. Verify that shaft turns CW (viewed from shaft end of actuator).
3	Check the Auto/Manual Switch in Auto Mode.	Set the Auto/Manual Switch in the Auto position. Using the controller, drive the unit CCW and CW.
4	Replace the controller.	Refer to the replacement procedure in Section 8 – Replacement/Recommended Spare Parts. Or if an external controller is being used refer to it's Operators Manual.

9.2.6 Actuator CW/CCW Switch does not operate correctly.

Table 9-7 explains how to troubleshoot the actuator CW/CCW Switch.

Table 9-7 Troubleshooting the CW/CCW Switch

Step	What to Do	How To Do it or Where to Find the Instructions
1	Check that the CW/CCW Switch and the jumper on the NCS Output Board are correct.	Verify that when the CW/CCW Switch is toward the CCW position that jumper W10 on the NCS Output Board is between pins 1 and 2. See Figure 4-8.
2	Continue Step 1.	Verify that when the CW/CCW Switch is toward the CW position that jumper W10 on the NCS Output Board is between pins 2 and 3. See Figure 4-8.
3	Check terminal wiring.	Using the wiring label located on the cover of the actuator verify that the wiring to the units is correct.
4	Check Non-contact Sensor.	Verify that the NCS sensor is positioned correctly. Position actuator to 0 % SPAN for CCW drive (100 % SPAN for CW drive) and make sure NCS spoilers are in zero position. (See Figure 4-4.) Using a DVM, measure voltage between pins on W11. Voltage should be between 0.01 V and 0.02 V in ZERO position and should increment as actuator goes CCW. See Section 4 to recalibrate.
5	Replace CW/CCW Switch.	Refer to the replacement procedure in Section 8 – Replacement/Recommended Spare Parts. Or if an external controller is being used refer to it's Operators Manual.
6	Replace NCS Output Board.	Refer to the replacement procedure in Section 8 – Replacement/Recommended Spare Parts. Or if an external controller is being used refer to it's Operators Manual.

9.2.7 Actuator Up/Down action does not operate correctly.

Table 9-8 explains how to troubleshoot the Up/Down Actuator action.

Table 9-8 Troubleshooting the Up/Down Actuator Action

Step	What to Do	How To Do it or Where to Find the Instructions
1	Check motor by driving directly.	Apply the AC Main supply voltage to TB-5. Actuator should drive in the Up direction. If not replace motor.
2	Check motor by driving directly.	Apply the AC Main supply voltage to TB-6. Actuator should drive in the Down direction. If not replace motor.
3	Check Limit Switch operation.	Apply the AC Main supply voltage to TB-9. Actuator should drive in the Up direction. If not check adjustment of Limit Switches and replace SW2 if necessary.
4	Check Limit Switch operation.	Apply the AC Main supply voltage to TB-8. Actuator should drive in the Down direction. If not check adjustment of Limit Switches and replace SW1 if necessary.