

Ignition spark generator

**For atmospheric gas burners.
Mains and high-voltage cables with plug
connectors.**

INTRODUCTION

The ZT 870 ignition spark generator is particularly suitable for use with the TFI 812 control box, for fully automatic ignition of atmospheric gas burner systems.

CONSTRUCTIONAL FEATURES

The transformer windings and the controlling electronics are contained in a temperature and impact resistant plastic housing, and sealed in a PU resin material which provides optimal protection from dampness and dirt. One of the two mounting lugs is also designed to provide the earth/ground connection. Plug connectors for the mains and high voltage cables allow quick and simple installation.

DESCRIPTION OF OPERATION

An electronic circuit produces approx. 50 sparks per second. The voltage of these sparks is increased by the transformer to approx. 16 kV. The secondary voltage as well as the spark energy are independent of the mains frequency and mains voltage. A reduction in the mains voltage simply causes the spark rate to drop, or respectively, to rise, should the mains voltage be too high. Interference to ionisation flame detection is avoided by the very short spark interval and also by the stability of the ignition spark.

INSTALLATION INSTRUCTIONS

The applicable installation regulations must be observed when mounting and wiring the unit. The ignition cable should be kept as short as possible in order to avoid radio interference and a drop in performance. The compact dimensions and simple installation procedure allow the ZT 870 ignition spark generator to be positioned close to the ignition electrode.



TECHNICAL DATA

Supply voltage	220 / 240 V (-15... +10%) 50 Hz (40 - 60 Hz)
Connections:	
Live / neutral	Satronic 2-pin angled plug
Earth	Mounting lug
High voltage	ø 4 mm plug
Power consumption	17 mA
Switched on time	50% in 3 min.
Interference level	<N
Ignition voltage	16 kV (amplitude)
Ignition current	200 mA (amplitude)
Spark frequency	Approx. 50 Hz
Energy per spark	4 mJ
Spark gap	2... 5 mm
Ignition cable	Silicone, ø 7 mm Standard length, 30 cm
Insulation standard	IP 40
Permissible ambient temperature	-20° C... +60° C
Mounting attitude	any
Weight	220 g

The ZT 870 is also available for a supply voltage of 110/120 V.

ZT 870 DIMENSIONS

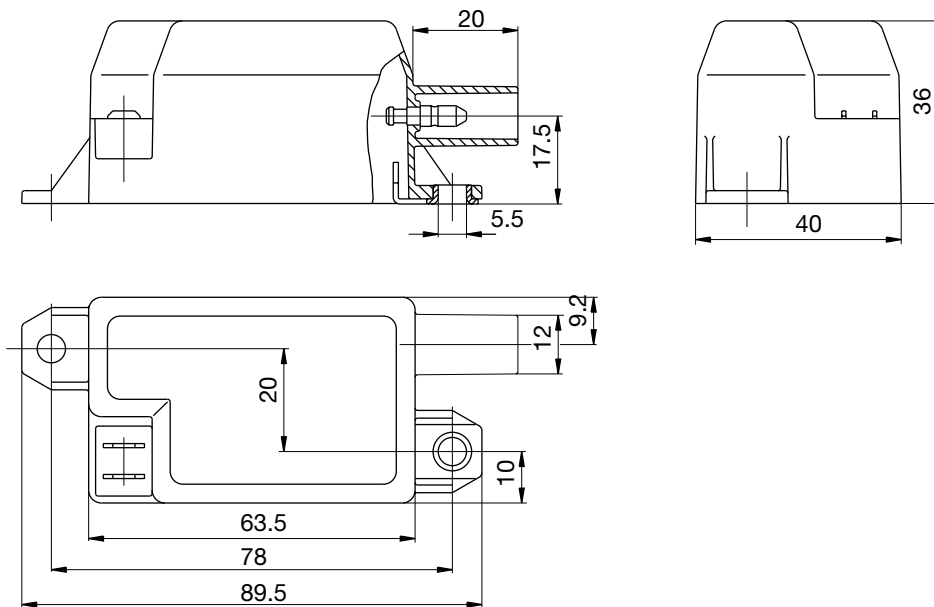

ORDERING INFORMATION

ITEM	DESIGNATION	ITEM NO.
Ignition transformer	ZT 870	13000
Mains cable	ZT 870 supply cord 0.3 m	7293001
Ignition cable	ZT 870 ignition cable 0.3 m	72730
Alternative ign. cable	ZT 870 ignition cable 1 m	72710

The above ordering information refers to the standard version.
Special versions are also included in our product range.

Specifications subject to change without notice.

ZT 870

satronic
A Honeywell Company

Satronic AG
Brüelstrasse 7
Postfach 324
CH-8157 Dielsdorf